





**Mantén el catálogo
siempre actualizado**



**Keep the catalogue
always updated**

Actualizaciones catálogo 2025

Catalogue updates 2025

ACTUALIZACIONES / 30 ene

PAG.

| | |
|-----|---|
| 321 | Corrección medida GN 2/1 |
| 234 | Corrección pulgadas en referencias: 8111, 8112 y 8116 |

UPDATES / 30 gen

PAG.

| | |
|-----|--|
| 321 | Correction measure 2/1 GN |
| 234 | Inch correction in references: 8111, 8112 and 8116 |



INSPIRING CREATORS



En Comas existimos para inspirar y empoderar a los creadores culinarios profesionales, aquellos que quieren dar rienda suelta a su pasión creativa y persiguen la excelencia culinaria en cada gesto, en cada plato, en cada detalle.

Desde hace más de treinta años, siendo fieles a nuestros principios, creemos que el futuro está lleno de nuevas oportunidades, desafíos y aprendizajes.

Nos apasiona pensar en lo que está por venir y, para ello, hemos redefinido nuestra estrategia y nuestra identidad de marca que os presentamos en este catálogo 2025.

Comas, Inspiring Creators no es solo un lema, es nuestra promesa y es nuestro propósito. Queremos ser una fuente de inspiración para los profesionales excelentes a los que servimos y, al mismo tiempo, nos dejamos inspirar por todos vosotros.

Juntos queremos construir el futuro de la creatividad culinaria, y para ello tenemos los mejores productos e ingredientes, esto es Comas.

At Comas we exist to inspire and empower professional culinary creators, those who want to unleash their creative passion and pursue culinary excellence in every gesture, in every dish, in every detail.

For more than thirty years, being faithful to our principles, we have believed that the future is full of new opportunities, challenges and learning.

We are passionate about thinking about what is to come and, to this end, we have redefined our strategy and our brand identity, which we present you in this 2025 catalogue.

Comas, Inspiring Creators is not just a slogan, it is our promise and our purpose. We want to be a source of inspiration for the excellent professionals we serve, and, at the same time, we allow ourselves to be inspired by all of you.

Together we want to build the future of culinary creativity, and for this we have the best products and ingredients, this is Comas.

Dani Comas, CEO

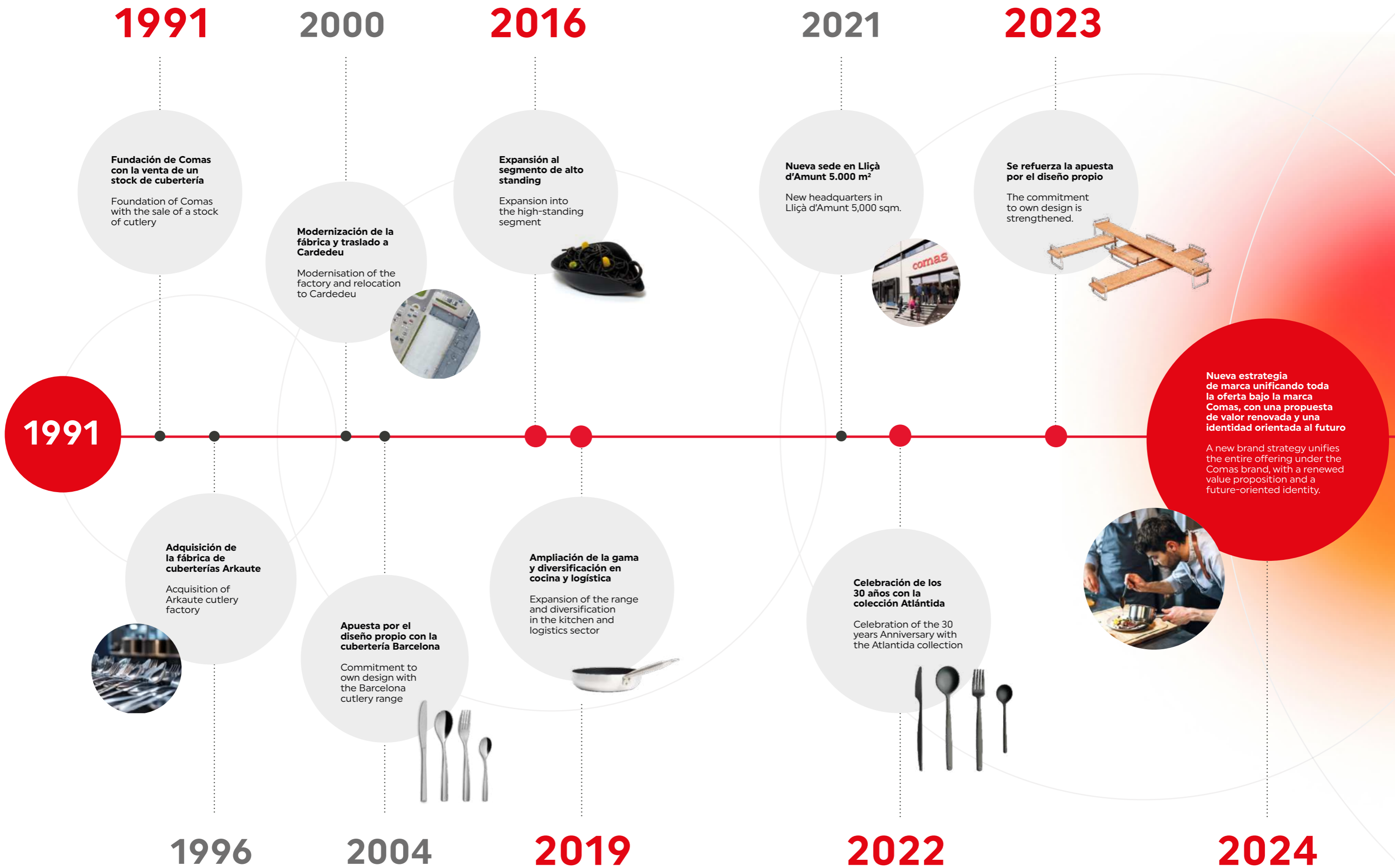

Nuestra promesa

Somos el socio global para creadores profesionales en la parte posterior, frontal y central de la industria hotelera.

Our promise

We are the global partner for creative professionals at the back, front and centre of the hospitality industry.

La forma de ser y de hacer

En Comas compartimos con nuestros clientes la búsqueda constante de lo extraordinario. Aprendemos y mejoramos juntos compartiendo conocimientos, superando desafíos y acumulando experiencias.

Creemos en el valor de reconocer y potenciar el talento, colaborando con expertos, universidades, diseñadores y de una selecta red de aliados.

En Comas, siempre estamos al lado de los profesionales porque esta es nuestra esencia.

The way we are and the way we do

At Comas we share with our clients the constant pursuit of the extraordinary. We learn and improve together by sharing knowledge, overcoming challenges and accumulating experience.

We believe in the value of recognising and promoting talent, collaborating with experts, universities, designers and a select network of allies.

At Comas, we are always at the side of professionals because this is our essence.

El conocimiento integrador

Diseñamos, producimos y comercializamos productos buscando la escalabilidad, eficiencia, calidad y competitividad. Así aportamos soluciones efectivas para satisfacer las necesidades de los profesionales más exigentes.

Nuestro portafolio, en constante evolución, abarca cubtería, cocina, logística, sala, bar, buffet, catering y brasa, y continuará creciendo para cubrir las futuras necesidades que puedan surgir de los profesionales porque esta es nuestra esencia.

Integrating knowledge

We design, produce and market products seeking scalability, efficiency, quality and competitiveness. This is how we provide effective solutions to satisfy the needs of the most demanding professionals.

Our constantly evolving portfolio covers cutlery, kitchen, logistics, dining room, bar, buffet, catering and grill, and will continue to grow to meet future needs that may arise.



ELISAVA

Escuela Universitaria de Barcelona
Diseño e Ingeniería



Innovación con propósito

En Comas, apostamos por un diseño que marca la diferencia. Con un equipo interno y colaboraciones externas, creamos colecciones únicas. Desde 2018, nuestros productos han recibido premios de diseño, consolidando nuestro prestigio y creatividad.

Colaboramos con universidades de diseño e ingeniería, desafiando a los estudiantes con retos y proyectos innovadores. Estas alianzas nos permiten crecer juntos en un entorno de aprendizaje mutuo.

Innovation with purpose

At Comas, we are committed to design that makes a difference. With an in-house team and external collaborations, we create unique collections. Since 2018, our products have received design awards, consolidating our prestige and creativity.

We collaborate with design and engineering universities, challenging students with innovative challenges and projects. These partnerships allow us to grow together in a mutual learning environment.

Premios / Awards



- 2018** ASTER
- 2018** MAGNOLIA
- 2020** SAKURA
- 2020** LAB
- 2021** LAB ACCESSORIES



- 2019** BAOBAB
- 2019** KODAI
- 2020** LAB



- 2021** LES ESSENCES



- 2018** BAOBAB
- 2023** ATLÁNTIDA
- 2023** BOLETUS
- 2024** PLAISIR



- 2019** ASTER
- 2023** BAUHAUS



- 2022** ATLÁNTIDA
- 2024** PLAISIR



NACAR

Agencia de diseño estratégico especializada en diseño industrial, soluciones digitales e innovación. Top 25 global según iF Awards.

Strategic design agency specialising in industrial design, digital solutions and innovation. Top 25 global according to iF Awards.

Comas y la apuesta por el diseño

Apostamos por diseñadores, por talento, por la experiencia de creadores que nos inspiran y dan forma a nuestras ideas y soluciones, con un carácter único.

Comas and the commitment to design

We are committed to designers, to talent, to the experience of creators who inspire us and give shape to our ideas and solutions, with a unique character.



CHRISTOPHE MATHIEU

Interiorista belga, dedicado al diseño industrial, basado en Barcelona. Trabajó años en Milán con estudios de arquitectura y diseño.

Belgian interior designer, dedicated to industrial design, based in Barcelona. He worked for years in Milan with architecture and design studios.



ULI MARCHSTEINER

Diseñador austriaco residente en España con foco en vajilla, cristalería, cubertería, mobiliario e iluminación. Experto en curaduría.

Austrian designer based in Spain with a focus on tableware, glassware, cutlery, furniture and lighting. Curatorial expert.



LÚCID

Lúcid es una agencia de diseño que crea productos y experiencias centradas en el planeta y el usuario. Su misión es empoderar a las organizaciones para alcanzar la excelencia y distinción a través de estrategias de diseño global.

Lúcid is a design agency that creates planet and user-centric products and experiences. Their mission is to empower organizations to achieve excellence and distinction through global design strategies.



PABLO CASTILLO

Diseñador industrial independiente, formado en la universidad de Zaragoza y Elisava. Concibe el diseño como generador de impacto positivo.

Independent industrial designer, trained at the University of Zaragoza and Elisava. He conceives design as a generator of positive impact.



NIL CARBÓ

Diseñador, ilustrador y fotógrafo. Graduado en la Universidad de Barcelona. Basado en Berlín. También trabaja en el mundo de la moda.

Designer, illustrator and photographer. Graduated from the University of Barcelona. Based in Berlin. Also works in the fashion world.

BAHÍGÜELL

Agencia de diseño de producto independiente de Girona. Colaboradores estrechos de Comas y creadores de la gama de productos Caliu.

Independent product design agency from Girona. Close collaborators of Comas and creators of the Caliu product range.



Comas y la visión de nuestro chef

Contar con la experiencia de un chef profesional como Xavier Corominas permite a Comas estar verdaderamente cerca de las necesidades del sector.

Su conocimiento profundo de la cocina, la logística y el uso de utensilios nos ayuda a crear productos pensados para maximizar la funcionalidad en cada espacio culinario.

Comas and the vision of our chef

Having the experience of a professional chef like Xavier Corominas allows Comas to be truly close to the needs of the sector.

His in-depth knowledge of the kitchen, logistics and the use of utensils helps us to create products designed to maximise functionality in each culinary space.



La figura del chef en nuestro equipo nos aporta experiencia y refuerza el compromiso que tenemos de aprender continuamente de los profesionales que inspiran y guían nuestra innovación.

Estar al lado de quienes viven la cocina día a día es la clave de nuestro éxito y de nuestro vínculo con el mundo HORECA.

The figure of the chef in our team brings us experience and reinforces our commitment to continually learn from the professionals who inspire and guide our innovation.

Being at the side of those who live the kitchen on a daily basis is the key to our success and our link with the HORECA world.

Colaboradores: creciendo juntos

Creemos en las colaboraciones como motor de crecimiento. Nuestros colaboradores aportan una visión y experiencia que enriquecen nuestros productos, elevando el estándar de calidad y diseño.

Trabajar junto a ellos nos permite aprender, innovar y mantenernos a la vanguardia del sector.

Su pasión, experiencia y especialización son el valor añadido que nos diferencia.

UTSET
1894

Con 130 años de historia, Utset es una empresa dedicada a la fabricación, venta y afilado de cuchillos. Juntos creamos piezas únicas, de tradición artesana y experta, de forma industrial y al alcance de los creadores más exigentes.

With 130 years of history, Utset is a company dedicated to the manufacture, sale and sharpening of knives. Together we create unique pieces, with a tradition of craftsmanship and expertise, in an industrial way and within the reach of the most demanding creators.



Agencia de diseño de producto con amplia experiencia en el sector gastronómico. Juntos creamos productos modernos, atemporales y funcionales que elevan la experiencia gastronómica.

Product design agency with extensive experience in the gastronomic sector. Together we create modern, timeless and functional products that elevate the gastronomic experience.

L U E S M A  V E G A

Luesma & Vega es un estudio dedicado al diseño y producción de objetos artísticos en vidrio con técnicas contemporáneas que ha colaborado con diseñadores, decoradores y empresas, resolviendo sus necesidades.

Luesma & Vega is a studio dedicated to the design and production of artistic glass objects with contemporary techniques that has collaborated with designers, decorators and companies, solving their needs.



Empresa comercializadora y distribuidora de leña y carbón. Ubicada en Polinyà, Barcelona.

Company that sells and distributes firewood and charcoal. Located in Polinyà, Barcelona.

Partners: growing together

We believe in partnerships as an engine for growth. Our partners bring a vision and experience that enrich our products, raising the standard of quality and design.

Working with them allows us to learn, innovate and stay at the forefront of the industry.

Their passion, experience and specialisation are the added value that sets us apart.



Sede y capacidad

Estamos en Lliçà d'Amunt, disponemos de modernas instalaciones de 5.000 m² repartidas en 3 plantas, con un almacén en el que caben más de 10.000 palés.

Y estamos a sólo 30 km de Barcelona.

Headquarters and capacity

We are located in Lliçà d'Amunt, with modern facilities of 5,000 m² spread over 3 floors, with a warehouse that can hold more than 10,000 pallets.

And we are only at 30 km from Barcelona.

Showroom

Exposición de todos nuestros artículos para mostrar a las visitas de primera mano la calidad y acabados de los productos Comas.

Showroom

Exhibition of all our articles to show visitors firsthand the quality and finish of Comas products..

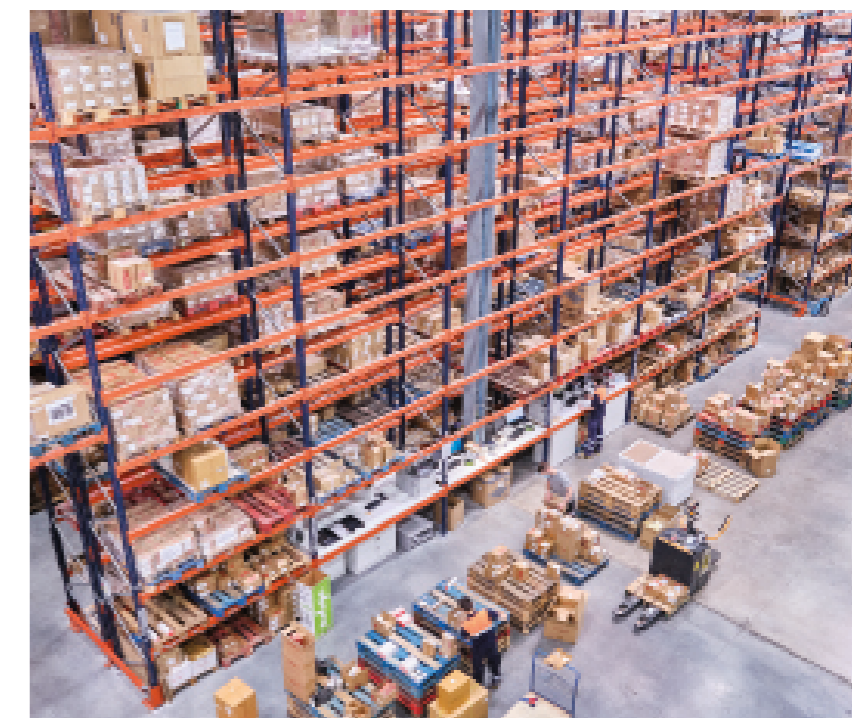

PRESENCIA / PRESENCE

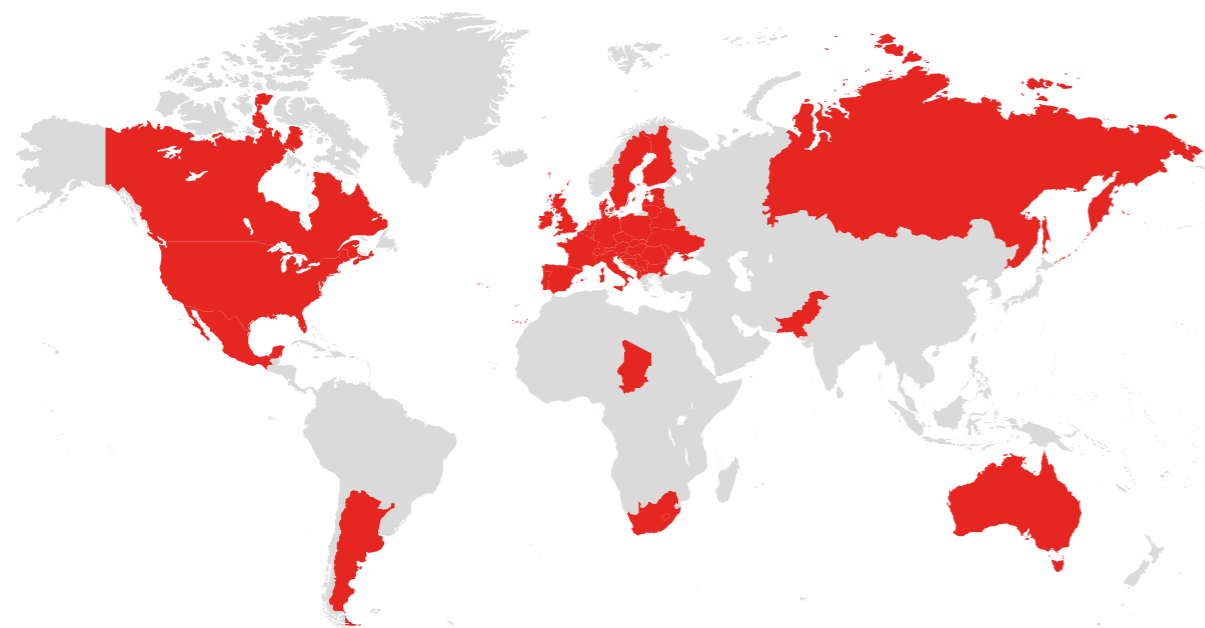

PRESENTES EN 57 PAÍSES / PRESENT IN 57 COUNTRIES

57

Germany, Belgium, Bulgaria, Burkina Faso, Cyprus, Croatia, Spain, United States of America, France, Greece, Hungary, Italy, Jordan, Lebanon, Lithuania, Luxembourg, Malta, Morocco, Mexico, Netherlands, Panama, Poland, Portugal, Andorra, U.K, Ireland, Slovakian, Rep., Dominican Rep., Reunion, Romania, Russia, Sweden, Tunisia, Ukraine, U.A.E, Austria, Chile, Denmark, Estonia, Georgia, Hong Kong, Iceland, Latvia, Moldova, Norway, Czech Republic, South Africa, Switzerland, Australia, Korea, Saudi Arabia, China, Peru, Finland, Kuwait, Sri Lanka.

CIFRAS / FIGURES

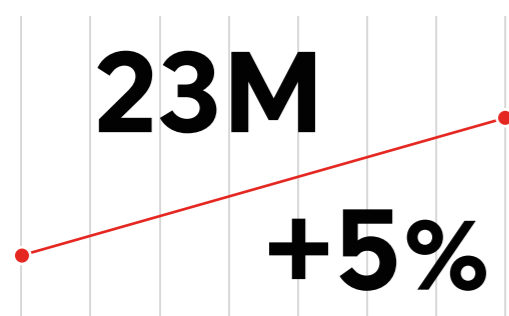

Previsión de crecimiento del 5% en 2024. EBITDA superior al 10%. Previsión de facturación de 23 M.

Expected growth of 5% in 2024. EBITDA of over 10%. Forecast turnover of 23 M.

MERCADOS: 45% EXPORTACIÓN
MARKETS: 45% EXPORT



45%
Internacional
International
55%
España
Spain

ALMACÉN / WAREHOUSE

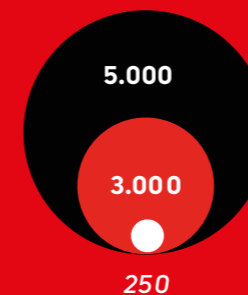

8.250 m²

Almacén central de 5.000 m². Almacén en BCN con capacidad para 10.000 palés. Almacén en Canarias de 250 m². 2 almacenes en China de 3.000 m² (Guangzhou y Tianjin)

Central warehouse of 5,000 m². Warehouse in BCN with capacity for 10,000 pallets. Warehouse in the Canary Islands of 250 m². 2 warehouses in China of 3,000 m² (Guangzhou and Tianjin).

OFICINA EN CHINA
OFFICE IN CHINA



CHN

Nueva oficina en China (Guangzhou)
New office in China (Guangzhou)

60% STOCK SOBRE VENTAS
60% STOCK OVER SALES

60%



95% de pedidos servidos en máximo 48 horas.
95% of orders served in maximum 48 hours.



+1800 DISTRIBUIDORES
+1800 DISTRIBUTORS

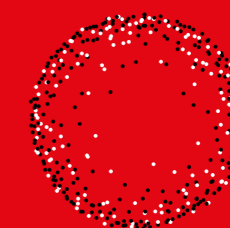

1.800

86 EMPLEADOS / EMPLOYEES

86

50 empleados internos
50 internal employees

36 comerciales externos
36 external sales staff



We are an inspiring
global partner for
professionals creators
at the back, front,
and core of the
hospitality industry.

CUBERTERÍA
CUTLERY



P. 24
INOX 18/10
INOX 18%
CHULETEROS

COCINA
KITCHEN



P. 216
CORTE
UTENSILIOS
PASTELERÍA
COCCIÓN
GASTRONORM

LOGISTICA
LOGISTICS



P. 334
RACKS
CONTENEDORES ISOTÉRMICOS

SALA
DINING ROOM



P. 352
VAJILLA
PRESENTACIÓN
MINIATURAS
SERVICIO MESA

BAR
BAR



P. 404
SERVICIO MESA
COCTELERÍA

BUFFET
BUFFET



P. 414
CAJAS MADERA
ACCESORIOS
ELEGANT
PINZAS

CATERING
CATERING



P. 436
AHUMADORES
LES ESSENCES

BRASA
GRILL



P. 464
CALIU
BRASA

CUBERTERÍA

CUTLERY



INOX 18/10

18/10 STAINLESS STEEL

- | | | | | | |
|-----|----------------------------|----|-----------------|-----|-------------------|
| 26 | ATLÁNTIDA | 63 | IRIS | 94 | NORTH XL |
| 100 | BAGUETTE S | 46 | KODAI VINTAGE | 93 | ONLINE |
| 98 | BAGUETTE XL | 48 | KODAI COLORS | 60 | OSLO |
| 108 | BARCELONA | 32 | LAB | 61 | OSLO OCEAN FREE |
| 64 | CALLAS | 38 | LAB ACCESSORIES | 69 | PALMA |
| 88 | CHEF | 34 | LAB COLORS | 44 | SAKURA |
| 70 | CONTOUR | 82 | LONDON | 65 | SANGIOVESE |
| 72 | CONTOUR COLORS | 84 | LONDON VINTAGE | 66 | SANGIOVESE COLORS |
| 62 | DALIA | 89 | LOTUS | 87 | TULIP |
| 56 | FLEUR DE LYS | 78 | MARANTA | 74 | VERSAILLES |
| 58 | FLEUR DE LYS VINTAGE BLACK | 80 | MARANTA VINTAGE | 75 | VERSAILLES COLORS |
| 92 | IBIZA | 52 | MINI KODAI | 106 | VIENA |
| 104 | INGLÉS M | 90 | MUNICH | 86 | VIOLET |
| 105 | INGLÉS S | 96 | NORTH M | | |
| 102 | INGLÉS XL | 97 | NORTH S | | |

INOX 18%

18% STAINLESS STEEL

- | | | | | | |
|-----|-----------------------|-----|-----------------|-----|-----------------|
| 172 | 1001 | 144 | CUBA | 142 | MADRID |
| 133 | 1001 BLACK | 173 | ECO | 120 | MALVARROSA |
| 174 | 1003 | 132 | FINGER FOOD | 146 | MIA |
| 162 | ALIDA | 156 | GRANADA S | 148 | NAPOLI |
| 116 | BCN COLORS | 154 | GRANADA XL | 175 | NERVIO |
| 114 | BCN SATIN | 140 | HIDRAULIC | 122 | NICE |
| 160 | BILBAO S | 141 | HIDRAULIC BLACK | 161 | OLYMPIA |
| 158 | BILBAO XL | 169 | HOTEL | 121 | OSLO ECO |
| 170 | BROOKLYN | 168 | HOTEL EXTRA ECO | 134 | SANTORINI |
| 124 | CANADA | 166 | HOTEL EXTRA M | 152 | SEVILLA S |
| 126 | CANADA VINTAGE | 165 | HOTEL EXTRA XL | 153 | SEVILLA VINTAGE |
| 127 | CANADA VINTAGE COLORS | 138 | KYOTO | 150 | SEVILLA XL |
| 139 | CHEESE | 137 | LOTUS FREE | 149 | VIEUX PARIS |
| 136 | CHEF FREE | 164 | LUNA | | |

OTROS

OTHERS

- | | |
|-----|-------------------------|
| 102 | ACTUALIZACIÓN / UPGRADE |
| 520 | FABRICACIÓN CUBIERTOS |
| 212 | FINISHES - PVD |
| 522 | MANTENIMIENTO CUBIERTOS |
| 110 | REPOSA CUBIERTOS |
| 171 | TAKE AWAY |



Descubre
las novedades
en cubertería.

Atlántida

Atlántida



El misterio de una experiencia gastronómica.
The mystery of a gastronomic experience..

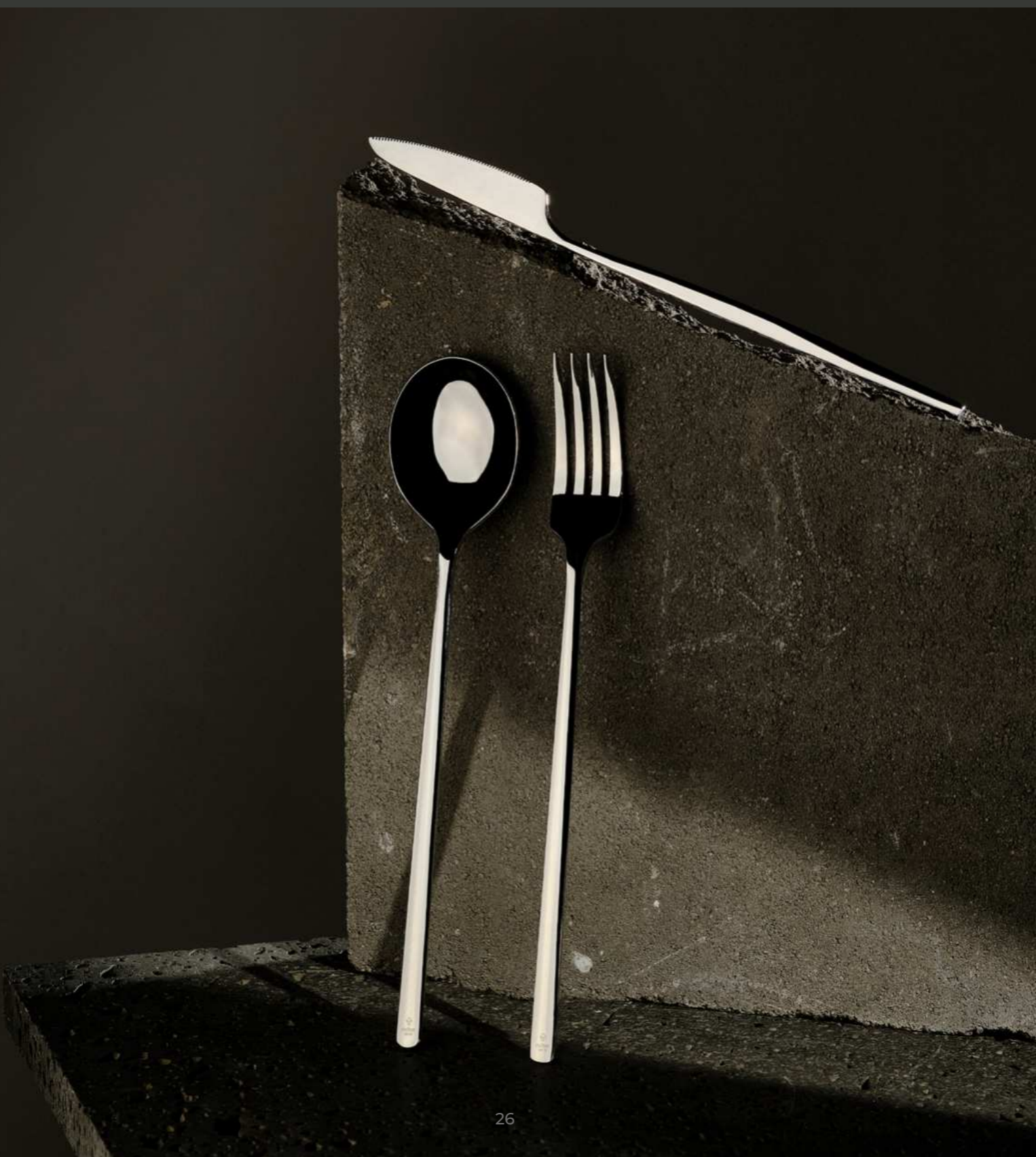

Esta colección, diseñada de la mano de Nacar Design, rinde homenaje a los 30 años de experiencia de la empresa, y una vez más, transmite su misión de querer acompañar y realzar el día a día de los profesionales y comensales.

Las piezas destacan por su elegancia y minimalismo gracias a un discurso de líneas fluidas y el acabado sofisticado que le otorga el acero inoxidable texturizado.

This collection, designed by the hand of Nacar Design, pays tribute to the company's 30 years of heritage and expertise. And once again, communicates its desire of accompanying and enhancing the day-to-day life of professionals and diners.

The pieces stand out for their elegance and minimalism thanks to a discourse of fluid lines and the sophisticated finish given by textured stainless steel.

comas30
YEARS



**Conoce más
sobre Atlántida.**





ATLANTIDA CONCEPT
COMAS COLLECTION FAMILY
MESA - LUNCH - MOKA



ATLANTIDA MESA

ATLANTIDA LUNCH

MOKA

INOX 18/10 / 6mm / Mirror

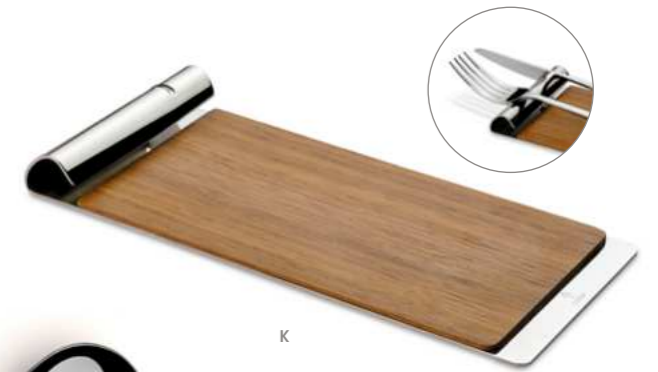

Everest + Atlántida



- A **11582** CUCHILLO CHULETERO EVEREST
steak knife, couteau steak, coltello bistecca, steakmesser
- B **11583** TENEDOR CHULETERO EVEREST
steak knife, couteau steak, coltello bistecca, steakmesser
- C **8586** CUCHILLO MESA
table knife, couteau table, coltello tavola, tafelmesser
- D **8587** CUCHARA MESA
table spoon, cuillère table, cucchiaio tavola, tafellöffel
- E **8588** TENEDOR MESA
table fork, fourchette table, forchetta tavola, tafelgabel
- F **8656** CUCHARA SALSA
sauce spoon, cuillère a sauce, cucchiaio salsa, saucenlöffel
- G **8589** CUCHILLO LUNCH
cake knife, couteau gâteau, coltello dolce, kuchenmesser
- H **8591** CUCHARA LUNCH
cake spoon, cuillère gâteau, cucchiaio dolce, lunch löffel
- I **8590** TENEDOR LUNCH
cake fork, fourchette gâteau, forchetta dolce, kuchengabel
- J **8592** CUCHARA CAFÉ
coffee/moka spoon, cuillère moka, cucchiaio moka, mokkalöffel
- K **10431** REPOSA CUBIERTOS
cutlery holder, plateau à couverts, porta posate, schneidewagen

9773 24 PIEZAS
24 pieces, écrin 24 pièces, bauletto 24 pz., 24 stück

| UE | MOQ | ▶ mm | ✕ mm |
|------------------|-----|------|------|
| 0/6/60/540/2160 | 60 | 220 | |
| 0/6/60/540/2160 | 60 | 206 | 6 |
| 0/6/60/1920/5760 | 60 | 226 | |
| 0/6/60/1920/5760 | 60 | 215 | 6 |
| 0/6/60/1920/5760 | 60 | 218 | 6 |
| 0/6/60/1920/5760 | 60 | 216 | 6 |
| 0/6/60/1920/5760 | 60 | 169 | |
| 0/6/60/1920/5760 | 60 | 163 | 5 |
| 0/6/60/1920/5760 | 60 | 160 | 5 |
| 0/6/60/1920/5760 | 60 | 109 | 3,5 |
| 0/4/48 | 4 | 190 | 1,5 |
| 1/0/4 | 4 | | |

Atlántida Ice Black

INOX 18/10 / 6mm / Ice Black



| | UE | MOQ | ▶ mm | ✂ mm |
|---|------------------|-----|------|------|
| A 8579 CUCHILLO MESA table knife, couteau table, coltello tavola, tafelmesser | 0/6/60/1920/5760 | 60 | 226 | |
| B 8580 CUCHARA MESA table spoon, cuillère table, cucchiaio tavola, tafellöffel | 0/6/60/1920/5760 | 60 | 215 | 6 |
| C 8581 TENEDOR MESA table fork, fourchette table, forchetta tavola, tafelgabel | 0/6/60/1920/5760 | 60 | 218 | 6 |
| D 8655 CUCHARA SALSА sauce spoon, cuillère a sauce, cucchiaio salsa, saucenlöffel | 0/6/60/1920/5760 | 60 | 216 | 6 |
| E 8582 CUCHILLO LUNCH cake knife, couteau gâteau, coltello dolce, kuchenmesser | 0/6/60/1920/5760 | 60 | 169 | |
| F 8584 CUCHARA LUNCH cake spoon, cuillère gâteau, cucchiaio dolce, lunch löffel | 0/6/60/1920/5760 | 60 | 163 | 5 |
| G 8583 TENEDOR LUNCH cake fork, fourchette gâteau, forchetta dolce, kuchengabel | 0/6/60/1920/5760 | 60 | 160 | 5 |
| H 8585 CUCHARA CAFÉ coffee/moka spoon, cuillère moka, cucchiaio moka, mokkalöffel | 0/6/60/1920/5760 | 60 | 109 | 3,5 |

INOX STAINLESS STEEL 304

9772 24 PIEZAS
24 pieces, écriin 24 pièces, bauletto 24 pz., 24 stück

NEW

Atlántida Polvo de Luna

INOX 18/10 / 6mm / Shotblasting



Everest + Atlántida

BEST COMBINATION

| | UE | MOQ | ▶ mm | ✂ mm |
|---|------------------|-----|------|------|
| A 10988 CUCHILLO CHULETERO EVEREST steak knife, couteau steak, coltello bistecca, steakmesser | 0/6/60/540/2160 | 60 | 220 | |
| B 10989 TENEDOR CHULETERO EVEREST steak knife, couteau steak, coltello bistecca, steakmesser | 0/6/60/540/2160 | 60 | 206 | 6 |
| C 10979 CUCHILLO MESA table knife, couteau table, coltello tavola, tafelmesser | 0/6/60/1920/5760 | 60 | 226 | |
| D 10981 CUCHARA MESA table spoon, cuillère table, cucchiaio tavola, tafellöffel | 0/6/60/1920/5760 | 60 | 215 | 6 |
| E 10980 TENEDOR MESA table fork, fourchette table, forchetta tavola, tafelgabel | 0/6/60/1920/5760 | 60 | 218 | 6 |
| F 10986 CUCHARA SALSА sauce spoon, cuillère a sauce, cucchiaio salsa, saucenlöffel | 0/6/60/1920/5760 | 60 | 216 | 6 |
| G 10982 CUCHILLO LUNCH cake knife, couteau gâteau, coltello dolce, kuchenmesser | 0/6/60/1920/5760 | 60 | 169 | |
| H 10983 TENEDOR LUNCH cake fork, fourchette gâteau, forchetta dolce, kuchengabel | 0/6/60/1920/5760 | 60 | 163 | 5 |
| I 10984 CUCHARA LUNCH cake spoon, cuillère gâteau, cucchiaio dolce, lunch löffel | 0/6/60/1920/5760 | 60 | 160 | 5 |
| J 10985 CUCHARA CAFÉ coffee/moka spoon, cuillère moka, cucchiaio moka, mokkalöffel | 0/6/60/1920/5760 | 60 | 109 | 3,5 |

INOX STAINLESS STEEL 304



INOX 18/10 / 2mm / Mirror



reddot design award
winner 2020

2020 WINNER
EUROPEAN
PRODUCT
DESIGN
AWARD

INOX
STAINLESS
STEEL
304



INOX 18/10 / 2mm / Mirror

| | UE | MOQ | ▶ mm | ✕ mm |
|--|---------------------|-----|------|------|
| A 7890 CUCHILLO MESA MONOBLOC monoblock table knife, couteau table monobloc, coltello tavola monobloc, monoblock tafelmesser | 0/12/120/1920/7680 | 60 | 160 | |
| B 6976 CUCHILLO MESA table knife, couteau table, coltello tavola, tafelmesser | 0/12/120/5400/10800 | 60 | 160 | 2,5 |
| C 6977 TENEDOR MESA table fork, fourchette table, forchetta tavola, tafelgabel | 0/12/120/5400/10800 | 60 | 154 | 2 |
| D 6978 CUCHARA MESA table spoon, cuillère table, cucchiaio tavola, tafellöffel | 0/12/120/5400/10800 | 60 | 153 | 2 |
| E 6979 TENEDOR ARROZ rice fork, fourchette à riz, forchetta riso, reisgabel | 0/12/120/5400/10800 | 60 | 148 | 2 |
| F 6980 PINCHO cocktail stick, stick à cocktail, spiedo, spie | 0/12/120/5400/16200 | 60 | 100 | 2 |
| G 6981 PINCHO LARGO large cocktail stick, stick à cocktail long, spiedo lungo, langer spie | 0/12/120/5400/16200 | 60 | 135 | 2 |
| H 6982 TENEDOR APERITIVO appetizer fork, fourchette apéritif, forchetta antipasto, aperitif gabel | 0/12/120/5400/16200 | 60 | 135 | 2 |
| I 6983 CUCHARA APERITIVO appetizer spoon, cuillère apéritif, cucchiaio antipasto, aperitif löffel | 0/12/120/5400/16200 | 60 | 135 | 2 |
| J 6984 CUCHARA MOKA coffee/moka spoon, cuillère moka, cucchiaio moka, mokkalöffel | 0/12/120/5400/16200 | 60 | 101 | 1,5 |
| K 6985 CUCHARA LUNCH cake spoon, cuillère gâteau, cucchiaio dolce, lunch löffel | 0/12/120/5400/16200 | 60 | 125 | 2 |
| L 6986 TENEDOR LUNCH cake fork, fourchette gâteau, forchetta dolce, kuchengabel | 0/12/120/5400/16200 | 60 | 125 | 2 |
| M 7891 CUCHILLO LUNCH MONOBLOC monoblock cake knife, couteau gâteau monobloc, coltello dolce monobloc, monobloc kuchenmesser | 0/12/120/1920/7680 | 60 | 135 | |
| N 6987 CUCHILLO LUNCH cake knife, couteau gâteau, coltello dolce, kuchenmesser | 0/12/120/5400/16200 | 60 | 135 | |
| O 6988 CUCHARA COCTEL LARGA large cocktail, cuillère cocktail longue, cucchiaio cocktail lunga, cocktail löffel- lang | 0/12/120/5400/10800 | 60 | 215 | 2 |
| P 6989 CUCHARA CAFÉ ESPÁTULA spatula coffee spoon, cuillère spatule, cucchiaio spatola, kaffeelöffel | 0/12/120/5400/16200 | 60 | 108 | 2 |
| Q 6995 PINZA LARGA long tong, pince longue, molla lunga, lange zange | 0/6/60/5400/10800 | 6 | 222 | 2 |
| R 6996 PINZA CORTA short tong, pince courte, molla corta, kurze zange | 0/6/60/5400/10800 | 6 | 160 | 2 |
| S 6997 PINZA ESPÁTULA spatula tong, pince spatule, molla spatola, kochzange | 0/6/60/5400/10800 | 6 | 160 | 2 |
| T 6998 CUCHARA DEGUSTACIÓN tasting spoon, cuillère dégustation, cucchiaio degustazione, probierlöffel | 0/6/60/5400/10800 | 6 | 86 | 2 |
| V 6999 CUCHARA DEGUSTACIÓN OVAL oval tasting spoon, cuillère dégustation ovale, cucchiaio degustazione ovale, probierlöffel oval | 0/6/60/5400/10800 | 6 | 101 | 2 |





INOX 18/10 / 2mm / Vintage Gold



**LAB
Collection.**

Lab Colors Vintage Gold

INOX 18/10 / 2mm / Vintage Gold



| | | UE | MOQ | ▶ mm | ✂ mm |
|---|--|---------------------|-----|------|------|
| A | 1539 CUCHILLO MESA MONOBLOC monoblock table knife, couteau table monobloc, coltello tavola monobloc, monoblock tafelmesser | 0/12/120/5400/10800 | 60 | 160 | |
| B | 1541 TENEDOR MESA table fork, fourchette table, forchetta tavola, tafelgabel | 0/12/120/5400/10800 | 60 | 154 | 2 |
| C | 1540 CUCHARA MESA table spoon, cuillère table, cucchiaio tavola, tafellöffel | 0/12/120/5400/10800 | 60 | 153 | 2 |
| D | 1542 TENEDOR ARROZ rice fork, fourchette à riz, forchetta riso, reisgabel | 0/12/120/5400/10800 | 60 | 148 | 2 |
| E | 1543 PINCHO cocktail stick, stick à cocktail, spiedo, spie | 0/12/120/5400/10800 | 60 | 100 | 2 |
| F | 1544 PINCHO LARGO large cocktail stick, stick à cocktail long, spiedo lungo, langer spie | 0/12/120/5400/10800 | 60 | 135 | 2 |
| G | 1545 TENEDOR APERITIVO appetizer fork, fourchette apéritif, forchetta antipasto, aperitif gabel | 0/12/120/5400/10800 | 60 | 135 | 2 |
| H | 1546 CUCHARA APERITIVO appetizer spoon, cuillère apéritif, cucchiaio antipasto, aperitif löffel | 0/12/120/5400/10800 | 60 | 135 | 2 |
| I | 1547 CUCHARA MOKA coffee/moka spoon, cuillère moka, cucchiaio moka, mokkalöffel | 0/12/120/5400/10800 | 60 | 101 | 1,5 |
| J | 1549 CUCHARA LUNCH cake spoon, cuillère gâteau, cucchiaio dolce, lunch löffel | 0/12/120/5400/10800 | 60 | 125 | 2 |
| K | 1550 TENEDOR LUNCH cake fork, fourchette gâteau, forchetta dolce, kuchengabel | 0/12/120/5400/10800 | 60 | 125 | 2 |
| L | 1548 CUCHILLO LUNCH MONOBLOC monoblock cake knife, couteau gâteau monobloc, coltello dolce monobloc, monobloc kuchenmesser | 0/12/120/5400/10800 | 60 | 135 | |
| M | 1551 CUCHARA COCTEL LARGA large cocktail, cuillère cocktail longue, cucchiaio cocktail lunga, cocktail löffel- lang | 0/12/120/5400/10800 | 60 | 215 | 2 |
| N | 1552 CUCHARA CAFÉ ESPÁTULA spatula coffee spoon, cuillère spatule, cucchiaio spatola, mokkalöffel | 0/12/120/5400/10800 | 60 | 108 | 2 |
| O | 1553 CUCHARA DEGUSTACIÓN tasting spoon, cuillère dégustation, cucchiaio degustazione, probierlöffel | 0/12/120/5400/10800 | 60 | 86 | 2 |
| P | 1554 CUCHARA DEGUSTACIÓN OVAL oval tasting spoon, cuillère dégustation ovale, cucchiaio degustazione ovale, probierlöffel oval | 0/12/120/5400/10800 | 60 | 101 | 2 |



Lab Colors Vintage Copper

INOX 18/10 / 2mm / Vintage Copper



Lab Colors Ice Black

INOX 18/10 / 2mm / Ice Black

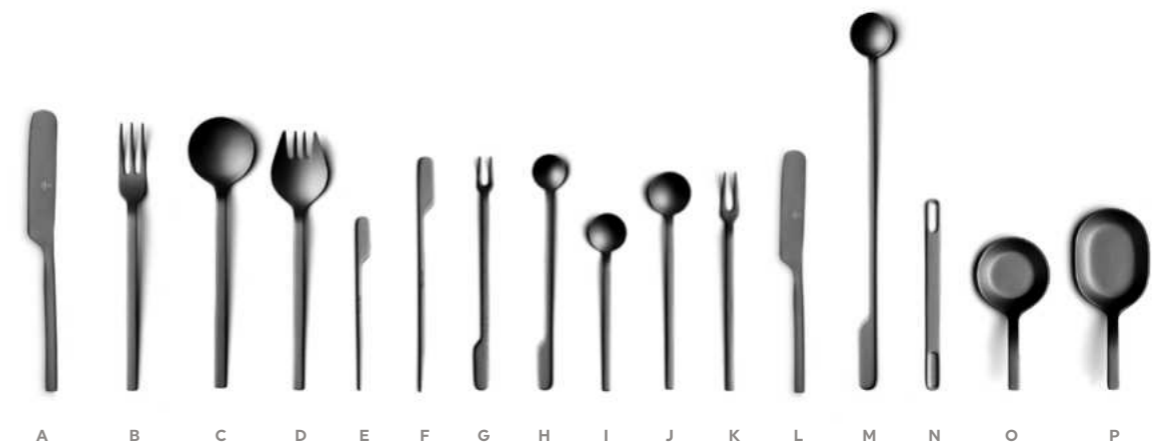

INOX
STAINLESS
STEEL
304

| | | UE | MOQ | ▶ mm | ✂ mm | |
|---|--|---------------------|-----|------|------|--|
| A | 1555 CUCHILLO MESA MONOBLOC monoblock table knife, couteau table monobloc, coltello tavola monobloc, monoblock tafelmesser | 0/12/120/5400/10800 | 60 | 160 | | |
| B | 1557 TENEDOR MESA table fork, fourchette table, forchetta tavola, tafelgabel, | 0/12/120/5400/10800 | 60 | 154 | 2 | |
| C | 1556 CUCHARA MESA table spoon, cuillère table, cucchiaio tavola, tafellöffel | 0/12/120/5400/10800 | 60 | 153 | 2 | |
| D | 1558 TENEDOR ARROZ rice fork, fourchette à riz, forchetta riso, reispabel | 0/12/120/5400/10800 | 60 | 148 | 2 | |
| E | 1559 PINCHO cocktail stick, stick à cocktail, spiedo, spie | 0/12/120/5400/10800 | 60 | 100 | 2 | |
| F | 1560 PINCHO LARGO large cocktail stick, stick à cocktail long, spiedo lungo, langer spie | 0/12/120/5400/10800 | 60 | 135 | 2 | |
| G | 1561 TENEDOR APERITIVO appetizer fork, fourchette apéritif, forchetta antipasto, aperitif gabel | 0/12/120/5400/10800 | 60 | 135 | 2 | |
| H | 1562 CUCHARA APERITIVO appetizer spoon, cuillère apéritif, cucchiaio antipasto, aperitif löffel | 0/12/120/5400/10800 | 60 | 135 | 2 | |
| I | 1563 CUCHARA MOKA coffee/moka spoon, cuillère moka, cucchiaio moka, mokkalöffel | 0/12/120/5400/10800 | 60 | 101 | 1,5 | |
| J | 1565 CUCHARA LUNCH cake spoon, cuillère gâteau, cucchiaio dolce, lunch löffel | 0/12/120/5400/10800 | 60 | 125 | 2 | |
| K | 1566 TENEDOR LUNCH cake fork, fourchette gâteau, forchetta dolce, kuchengabel | 0/12/120/5400/10800 | 60 | 125 | 2 | |
| L | 1564 CUCHILLO LUNCH MONOBLOC monoblock cake knife, couteau gâteau monobloc, coltello dolce monobloc, monobloc kuchenmesser | 0/12/120/5400/10800 | 60 | 135 | | |
| M | 1567 CUCHARA COCTEL LARGA large cocktail, cuillère cocktail longue, cucchiaio cocktail lunga, cocktail löffel- lang | 0/12/120/5400/10800 | 60 | 215 | 2 | |
| N | 1568 CUCHARA CAFÉ ESPÁTULA spatula coffee spoon, cuillère spatule, cucchiaio spatola, mokkalöffel | 0/12/120/5400/10800 | 60 | 108 | 2 | |
| O | 1569 CUCHARA DEGUSTACIÓN tasting spoon, cuillère dégustation, cucchiaio degustazione, probierlöffel | 0/12/120/5400/10800 | 60 | 86 | 2 | |
| P | 1570 CUCHARA DEGUSTACIÓN OVAL oval tasting spoon, cuillère dégustation ovale, cucchiaio degustazione ovale, probierlöffel oval | 0/12/120/5400/10800 | 60 | 101 | 2 | |

INOX
STAINLESS
STEEL
304

| | | UE | MOQ | ▶ mm | ✂ mm | |
|---|--|---------------------|-----|------|------|--|
| A | 8640 CUCHILLO MESA MONOBLOC monoblock table knife, couteau table monobloc, coltello tavola monobloc, monoblock tafelmesser | 0/12/120/5400/10800 | 60 | 160 | | |
| B | 7665 TENEDOR MESA table fork, fourchette table, forchetta tavola, tafelgabel, | 0/12/120/5400/10800 | 60 | 154 | 2 | |
| C | 8641 CUCHARA MESA table spoon, cuillère table, cucchiaio tavola, tafellöffel | 0/12/120/5400/10800 | 60 | 153 | 2 | |
| D | 8642 TENEDOR ARROZ rice fork, fourchette à riz, forchetta riso, reispabel | 0/12/120/5400/10800 | 60 | 148 | 2 | |
| E | 8643 PINCHO cocktail stick, stick à cocktail, spiedo, spie | 0/12/120/5400/10800 | 60 | 100 | 2 | |
| F | 8644 PINCHO LARGO large cocktail stick, stick à cocktail long, spiedo lungo, langer spie | 0/12/120/5400/10800 | 60 | 135 | 2 | |
| G | 8645 TENEDOR APERITIVO appetizer fork, fourchette apéritif, forchetta antipasto, aperitif gabel | 0/12/120/5400/10800 | 60 | 135 | 2 | |
| H | 8646 CUCHARA APERITIVO appetizer spoon, cuillère apéritif, cucchiaio antipasto, aperitif löffel | 0/12/120/5400/10800 | 60 | 135 | 2 | |
| I | 8647 CUCHARA MOKA coffee/moka spoon, cuillère moka, cucchiaio moka, mokkalöffel | 0/12/120/5400/10800 | 60 | 101 | 1,5 | |
| J | 8649 CUCHARA LUNCH cake spoon, cuillère gâteau, cucchiaio dolce, lunch löffel | 0/12/120/5400/10800 | 60 | 125 | 2 | |
| K | 8650 TENEDOR LUNCH cake fork, fourchette gâteau, forchetta dolce, kuchengabel | 0/12/120/5400/10800 | 60 | 125 | 2 | |
| L | 8648 CUCHILLO LUNCH MONOBLOC monoblock cake knife, couteau gâteau monobloc, coltello dolce monobloc, monobloc kuchenmesser | 0/12/120/5400/10800 | 60 | 135 | | |
| M | 8651 CUCHARA COCTEL LARGA large cocktail, cuillère cocktail longue, cucchiaio cocktail lunga, cocktail löffel- lang | 0/12/120/5400/10800 | 60 | 215 | 2 | |
| N | 8652 CUCHARA CAFÉ ESPÁTULA spatula coffee spoon, cuillère spatule, cucchiaio spatola, mokkalöffel | 0/12/120/5400/10800 | 60 | 108 | 2 | |
| O | 8653 CUCHARA DEGUSTACIÓN tasting spoon, cuillère dégustation, cucchiaio degustazione, probierlöffel | 0/12/120/5400/10800 | 60 | 86 | 2 | |
| P | 8654 CUCHARA DEGUSTACIÓN OVAL oval tasting spoon, cuillère dégustation ovale, cucchiaio degustazione ovale, probierlöffel oval | 0/12/120/5400/10800 | 60 | 101 | 2 | |

Lab Accessories



reddot design award
winner 2021

Lab Accessories

Servicio mesa / Table top



Comas presenta la nueva colección LAB ACCESSORIES. Un conjunto de platos y bases para servir, en diferentes materiales y colores que junto a la ya existente cubertería de Culter, te permitirá completar la experiencia de degustar aperitivos, tapas y arroces.

Todos los elementos de la colección siguen las mismas proporciones, ayudándote a crear múltiples composiciones, jugando con la modularidad y la combinación de colores, materiales y texturas.

Comas introduces its new LAB ACCESSORIES collection. A collection of dishes and serving platters in different materials and colours that goes perfectly with Culter's existing serving ware for you to make the experience of savouring canapés, tapas and rice dishes complete.

All the items in the collection are in the same proportions, so that you can create different compositions by exploiting their modularity and the combinations of colours, materials and textures.



Descubre la modularidad de LAB.





Lab Accessories

Servicio mesa / Table Top

Plato 1/4 ración redondo
1/4 ration circle plate
plateau 1/4 bassin rond
vassoio 1/4 porzione rotonda
1/4 portion quadratischer edelstahl teller



| REF. | W(mm) | L(mm) | € | UE / MOQ |
|------|-------|-------|---|---------------------|
| 8000 | 92,5 | 92,5 | | 0-4-16-864-2592 / 4 |

Plato 1/4 ración redondo doble
1/4 ration circle double plate
plateau 1/4 double bassin rond
vassoio 1/4 porzione doppia
1/4 portion rechteckiger edelstahl teller doppelt



| REF. | W(mm) | L(mm) | € | UE / MOQ |
|------|-------|-------|---|---------------------|
| 8004 | 92,5 | 185 | | 0-4-16-480-1920 / 4 |

Plato 1 ración oval
1 ration oval plate
plateau 1 bassin ovale
vassoio 1 porzione ovale
1 portion rechteckiger edelstahl teller



| REF. | W(mm) | L(mm) | € | UE / MOQ |
|------|-------|-------|---|--------------------|
| 8005 | 92,5 | 278 | | 0-4-16-288-864 / 4 |

Plato 1 ración redondo
1 ration circle plate
plateau 1 bassin rond
vassoio 1 porzione rotonda
1 portion quadratischer edelstahl teller



| REF. | W(mm) | L(mm) | € | UE / MOQ |
|------|-------|-------|---|---------------------|
| 8002 | 185 | 185 | | 0-4-16-240-1200 / 4 |

Plato 1/2 ración oval
1/2 ration oval plate
plateau 1/2 bassin ovale
vassoio 1/2 porzione ovale
ovale 1/2 portion rechteckiger edelstahl teller



| REF. | W(mm) | L(mm) | € | UE / MOQ |
|------|-------|-------|---|---------------------|
| 8003 | 92,5 | 185 | | 0-4-16-480-1920 / 4 |

Plato 1/2 ración oval + pinchos
1/2 ration oval plate + stick holder
plateau 1/2 bassin ovale + porte brochette
vassoio 1/2 porzione ovale + fori spiedini
1/2 portion rechteckiger edelstahl teller mit spießhalter



| REF. | W(mm) | L(mm) | € | UE / MOQ |
|------|-------|-------|---|---------------------|
| 8006 | 92,5 | 278 | | 0-4-16-352-1408 / 4 |

BAJO DEMANDA
ON DEMAND

Plato 1 ración redondo PVD
PVD 1 ration circle plate
plateau bassin rond PVD
vassoio 1 porzione rotonda PVD
PVD 1 portion quadratischer edelstahl teller



ACABADO
ICE
ICE FINISH

| REF. | COLOR | W(mm) | L(mm) | € | UE / MOQ |
|------|-------|-------|-------|---|--------------------|
| 8604 | ORO | 185 | 185 | | 0-4-16-240-720 / 4 |
| 8605 | COBRE | 185 | 185 | | 0-4-16-240-720 / 4 |
| 8606 | NEGRO | 185 | 185 | | 0-4-16-240-720 / 4 |

BAJO DEMANDA
ON DEMAND

Plato 1/2 ración oval PVD
PVD 1/2 ration oval plate
plateau 1/2 bassin ovale PVD
vassoio 1/2 porzione ovale PVD
PVD ovale 1/2 portion rechteckiger edelstahl teller



ACABADO
ICE
ICE FINISH

| REF. | COLOR | W(mm) | L(mm) | € | UE / MOQ |
|------|-------|-------|-------|---|--------------------|
| 8607 | ORO | 92,5 | 185 | | 0-4-16-288-864 / 4 |
| 8608 | COBRE | 92,5 | 185 | | 0-4-16-288-864 / 4 |
| 8609 | NEGRO | 92,5 | 185 | | 0-4-16-288-864 / 4 |

Base porcelana pequeña
Small porcelain tray
Petit plateau en porcelaine
Vassoio piccolo porcellana
Porzellantablett klein

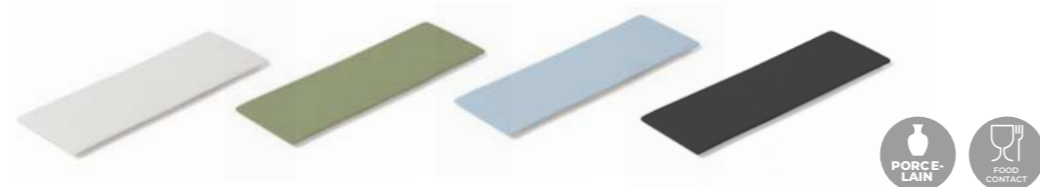

| REF. | COLOR | W(mm) | L(mm) | € | UE / MOQ |
|------|--------|-------|-------|---|--------------------|
| 8598 | BLANCO | 92,5 | 278 | | 0-4-16-192-960 / 4 |
| 8600 | VERDE | 92,5 | 278 | | 0-4-16-192-960 / 4 |
| 8602 | AZUL | 92,5 | 278 | | 0-4-16-192-960 / 4 |
| 8596 | NEGRO | 92,5 | 278 | | 0-4-16-192-960 / 4 |

Base porcelana grande
Double porcelain tray
Plateau en porcelaine double
Vassoio porcellana doppio
Doppelpetres porzellantablett

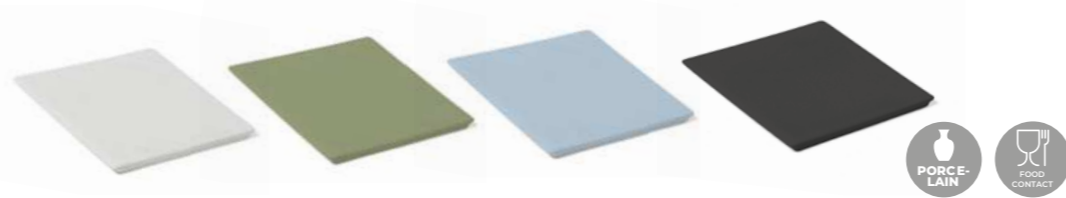

| REF. | COLOR | W(mm) | L(mm) | € | UE / MOQ |
|------|--------|-------|-------|---|--------------------|
| 8599 | BLANCO | 185 | 185 | | 0-4-16-240-720 / 4 |
| 8601 | VERDE | 185 | 185 | | 0-4-16-240-720 / 4 |
| 8603 | AZUL | 185 | 185 | | 0-4-16-240-720 / 4 |
| 8597 | NEGRO | 185 | 185 | | 0-4-16-240-720 / 4 |

Base madera
Wood tray
Plateau en bois
Vassoio legno
Holztablett



| REF. | SIZE | W(mm) | L(mm) | € | UE / MOQ |
|------|--------|-------|-------|---|---------------------|
| 8370 | SIMPLE | 92,5 | 278 | | 0-4-16-208-1040 / 4 |
| 8371 | DOBLE | 185 | 278 | | 0-4-16-208-624 / 4 |

Disco pinchos
Round stick holder
Orte brochette rond
Disco fori spiedini
Runder edelstahl spießhalter



| REF. | Ø(mm) | H(mm) | Para ref. / For ref. | € | UE / MOQ |
|------|-------|-------|----------------------|---|---------------------|
| 8001 | 71 | 35 | 8000 - 8004 | | 0-4-16-736-1472 / 4 |

Plato gest M
Gest plate M
Plateau en porcelaine gest M
Vassoio pocellana gest M
Gest porzellantablett M



| REF. | SIZE | H(mm) | W(mm) | L(mm) | € | UE / MOQ |
|-------|------|-------|-------|-------|---|---------------------|
| 9984 | S | 30 | 110 | 105 | | 0-4-16-512-1536 / 4 |
| 11808 | M | 30 | 145 | 200 | | 0-4-48-0-0 / 4 |



Conoce más sobre
LAB Accesories.



SAKURA
Collection.



INOX 18/10 / 5mm / Mirror



reddot design award
winner 2020



- A **6931** CUCHILLO MESA
table knife, couteau table, coltello tavola, tafelmesser
- B **6932** CUCHARA MESA
table spoon, cuillère table, cucchiaio tavola, tafellöffel
- C **6933** TENEDOR MESA
table fork, fourchette table, forchetta tavola, tafelgabel
- D **6934** CUCHARA RAMEN
ramen spoon, cuillère ramen, cucchiaio ramen, ramen löffel
- E **6935** SET PALILLOS
chopsticks set, set piques, set bacchette, e_stäbchen- set
- F **6936** PLATO PALILLOS PORCELANA
porcelain chopsticks plate, porcelaine assiette piques, piatto porcellana bacchette,
e_stäbchen- teller porzellan
- G **7869** SOPORTE CUBIERTOS
cutlery holder, panier à couverts, supporto coperte, besteckhalter
- H **6939** TENEDOR LUNCH
cake fork, fourchette gâteau, forchetta dolce, kuchengabel
- I **6940** CUCHARA CAFÉ
tea spoon, cuillère café, cucchiaio caffè, kaffeelöffel
- J **6941** CUCHARA MOKA
coffee/moka spoon, cuillère moka, cucchiaio moka, mokkalöffel
- K **9789** 24 PIEZAS
24 pieces, écriin 24 pièces, bauletto 24 pz., 24 stück

| UE | MOQ | ▶ mm | ✕ mm |
|------------------|-----|------|------|
| 0/6/60/1440/4320 | 60 | 228 | |
| 0/6/60/1440/4320 | 60 | 206 | 5 |
| 0/6/60/1440/4320 | 60 | 210 | 5 |
| 0/6/60/1440/4320 | 60 | 192 | 5 |
| 0/6/60/1440/4320 | 60 | 230 | 5,5 |
| 0/6/60/1440/4320 | 60 | | |
| 0/6/60/1440/4320 | 60 | 80 | 8,5 |
| 0/6/60/1440/4320 | 60 | 151 | 3,5 |
| 0/6/60/1440/4320 | 60 | 147 | 3 |
| 0/6/60/1440/4320 | 60 | 105 | 2 |
| 1/0/4 | 4 | | 5 |





INOX 18% Nickel Free / 3mm / Vintage



KODAI
Collection.

2019 WINNER
EUROPEAN
PRODUCT
DESIGN
AWARD

INOX
STAINLESS
STEEL
430

Kodai Vintage

INOX 18% Nickel Free / 3mm / Vintage



- A **7276** CUCHILLO MESA XL
table knife xl vintage, couteau table xl vintage, coltello tavola xl vintage, tafelmesser xl vintage
- B **7279** CUCHARA MESA XL
table spoon xl vintage, cuillère table xl vintage, cucchiaio tavola xl vintage, tafellöffel xl vintage
- C **7285** TENEDOR MESA 3 PUAS XL
table fork 3 prongs xl vintage, fourchette table xl 3 dents vintage, forchetta tavola xl 3 punte vintage, tafelgabel xl vintage
- D **6943** CUCHILLO MESA
vintage table knife, couteau table vintage, coltello tavola vintage, tafelmesser vintage
- E **6944** CUCHARA MESA
vintage table spoon, cuillère table vintage, cucchiaio tavola vintage, tafellöffel vintage
- F **6945** TENEDOR MESA 2 PUAS
vintage table fork 2 prongs, fourchette table 2 dents vintage, forchetta tavola 2 punte, tafelgabel 2
- G **6946** TENEDOR MESA 3 PUAS
vintage table fork 3 prongs, fourchette table 3 dents vintage, forchetta tavola 3 punte, tafelgabel 3
- H **6947** CUCHILLO MANTEQUILLA
vintage butter knife, couteau beurre, coltello burro, buttermesser
- I **6948** CUCHILLO LUNCH
vintage cake knife, couteau gâteau, coltello dolce, kuchenmesser
- J **6949** TENEDOR LUNCH
vintage cake fork, fourchette gâteau, forchetta dolce, kuchengabel
- K **6950** CUCHARA CAFÉ
vintage coffee spoon, cuillère café, cucchiaio caffè, kaffeelöffel
- L **6951** CUCHARA SIDE
vintage side spoon, cuillère side, cucchiaio side, löffel side
- M **6952** CUCHARA MOKA
vintage moka spoon, cuillère moka, cucchiaio moka, mokkalöffel
- N **6953** CUCHARA ARROZ
vintage rice spoon, cuillère à riz, cucchiaio riso, reislöffel
- O **6954** TENEDOR RASTRILLO
vintage wide fork, fourchette râteau, forchetta wide, tafelgabel wide

| | UE | MOQ | ▶ mm | ✂ mm |
|-------------|--|-------|-------|------|
| A | 0/12/120/2880/5760 | 60 | 212 | |
| B | 0/12/120/2880/5760 | 60 | 190 | 3 |
| C | 0/12/120/2880/5760 | 60 | 195 | 3 |
| D | 0/12/120/1800/9000 | 60 | 183 | |
| E | 0/12/120/1800/9000 | 60 | 170 | 2,5 |
| F | 0/12/120/1800/9000 | 60 | 179 | 2,5 |
| G | 0/12/120/1800/9000 | 60 | 163 | 2,5 |
| H | 0/12/120/1800/9000 | 60 | 155 | |
| I | 0/12/120/1800/9000 | 60 | 133 | |
| J | 0/12/120/1800/9000 | 60 | 138 | 2 |
| K | 0/12/120/1800/9000 | 60 | 115,4 | 1,7 |
| L | 0/12/120/1800/9000 | 60 | 93,5 | 2 |
| M | 0/12/120/1800/9000 | 60 | 97,5 | 1,7 |
| N | 0/12/120/1680/6720 | 60 | 90 | 2,5 |
| O | 0/12/120/1680/6720 | 60 | 113 | 2,5 |
| 9791 | 24 PIEZAS 24 pieces, écriin 24 pièces, bauletto 24 pz, 24 stück | 1/0/4 | 4 | 3 |





INOX
STAINLESS
STEEL
430



INOX 18% Nickel Free / 3mm / Vintage Gold



| | UE | MOQ | ▶ mm | ✂ mm |
|---|--------------------|-----|-------|------|
| A 7278 CUCHILLO MESA XL table knife xl vintage, couteau table xl vintage, coltello tavola xl vintage, tafelmesser xl vintage | 0/12/120/2880/5760 | 60 | 212 | |
| B 7281 CUCHARA MESA XL table spoon xl vintage, cuillère table xl vintage, cucchiaio tavola xl vintage, tafelloffel xl vintage | 0/12/120/2880/5760 | 60 | 190 | 3 |
| C 7287 TENEDOR MESA 3 PUAS XL table fork 3 prongs xl vintage, fourchette table xl 3 dents vintage, forchetta tavola xl 3 punte vintage, tafelgabel xl vintage | 0/12/120/2880/5760 | 60 | 195 | 3 |
| D 7081 CUCHILLO MESA vintage table knife, couteau table vintage, coltello tavola vintage, tafelmesser vintage | 0/12/120/1800/9000 | 60 | 183 | |
| E 7082 CUCHARA MESA vintage table spoon, cuillère table vintage, cucchiaio tavola vintage, tafelloffel vintage | 0/12/120/1800/9000 | 60 | 170 | 2,5 |
| F 7083 TENEDOR MESA 2 PUAS vintage table fork 2 prongs, fourchette table 2 dents vintage, forchetta tavola 2 punte, tafelgabel 2 | 0/12/120/1800/9000 | 60 | 179 | 2,5 |
| G 7084 TENEDOR MESA 3 PUAS vintage table fork 3 prongs, fourchette table 3 dents vintage, forchetta tavola 3 punte, tafelgabel 3 | 0/12/120/1800/9000 | 60 | 163 | 2,5 |
| H 7085 CUCHILLO MANTEQUILLA vintage butter knife, couteau beurre, coltello burro, buttermesser | 0/12/120/1800/9000 | 60 | 155 | |
| I 7086 CUCHILLO LUNCH vintage cake knife, couteau gâteau, coltello dolce, kuchenmesser | 0/12/120/1800/9000 | 60 | 133 | |
| J 7087 TENEDOR LUNCH vintage cake fork, fourchette gâteau, forchetta dolce, kuchengabel | 0/12/120/1800/9000 | 60 | 138 | 2 |
| K 7088 CUCHARA CAFÉ vintage coffee spoon, cuillère café, cucchiaio caffè, kaffeelöffel | 0/12/120/1800/9000 | 60 | 115,4 | 1,7 |
| L 7089 CUCHARA SIDE vintage side spoon, cuillère side, cucchiaio side, löffel side | 0/12/120/1800/9000 | 60 | 93,5 | 2 |
| M 7090 CUCHARA MOKA vintage moka spoon, cuillère moka, cucchiaio moka, mokkalöffel | 0/12/120/1800/9000 | 60 | 97,5 | 1,7 |
| N 7091 CUCHARA ARROZ vintage rice spoon, cuillère à riz, cucchiaio riso, reislöffel | 0/12/120/1680/6720 | 60 | 90 | 2,5 |
| O 7092 TENEDOR RASTRILLO vintage wide fork, fourchette râteau, forchetta wide, tafelgabel wide | 0/12/120/1680/6720 | 60 | 113 | 2,5 |
| 9793 24 PIEZAS 24 pieces, écrin 24 pièces, bauletto 24 pz., 24 stück | 1/0/4 | 4 | | 3 |



Kodai Vintage Copper

INOX 18% Nickel Free / 3mm / Vintage Copper



Kodai Vintage Black

INOX 18% Nickel Free / 3mm / Vintage Black



INOX STAINLESS STEEL 430

| | | UE | MOQ | ▶ mm | ✂ mm | |
|-------------|---|--------------------|-----|-------|------|---|
| A | 4929 CUCHILLO MESA XL table knife xl vintage, couteau table xl vintage, coltello tavola xl vintage, tafelmesser xl vintage | 0/12/120/2880/5760 | 60 | 212 | | |
| B | 4930 CUCHARA MESA XL table spoon xl vintage, cuillère table xl vintage, cucchiaio tavola xl vintage, tafelöffel xl vintage | 0/12/120/2880/5760 | 60 | 190 | 3 | |
| C | 4931 TENEDOR MESA 3 PUAS XL table fork 3 prongs xl vintage, fourchette table xl 3 dents vintage, forchetta tavola xl 3 punte vintage, tafelgabel xl vintage | 0/12/120/2880/5760 | 60 | 195 | 3 | |
| D | 4932 CUCHILLO MESA vintage table knife, couteau table vintage, coltello tavola vintage, tafelmesser vintage | 0/12/120/1800/9000 | 60 | 183 | | |
| E | 4933 CUCHARA MESA vintage table spoon, cuillère table vintage, cucchiaio tavola vintage, tafelöffel vintage | 0/12/120/1800/9000 | 60 | 170 | 2,5 | |
| F | 4934 TENEDOR MESA 2 PUAS vintage table fork 2 prongs, fourchette table 2 dents vintage, forchetta tavola 2 punte, tafelgabel 2 | 0/12/120/1800/9000 | 60 | 179 | 2,5 | |
| G | 4935 TENEDOR MESA 3 PUAS vintage table fork 3 prongs, fourchette table 3 dents vintage, forchetta tavola 3 punte, tafelgabel 3 | 0/12/120/1800/9000 | 60 | 163 | 2,5 | |
| H | 4936 CUCHILLO MANTEQUILLA vintage butter knife, couteau beurre, coltello burro, buttermesser | 0/12/120/1800/9000 | 60 | 155 | | |
| I | 4937 CUCHILLO LUNCH vintage cake knife, couteau gâteau, coltello dolce, kuchenmesser | 0/12/120/1800/9000 | 60 | 133 | | |
| J | 4938 TENEDOR LUNCH vintage cake fork, fourchette gâteau, forchetta dolce, kuchengabel | 0/12/120/1800/9000 | 60 | 138 | 2 | |
| K | 4939 CUCHARA CAFÉ vintage coffee spoon, cuillère café, cucchiaio caffè, kaffeelöffel | 0/12/120/1800/9000 | 60 | 115,4 | 1,7 | |
| L | 4940 CUCHARA SIDE vintage side spoon, cuillère side, cucchiaio side, löffel side | 0/12/120/1800/9000 | 60 | 93,5 | 2 | |
| M | 4941 CUCHARA MOKA vintage moka spoon, cuillère moka, cucchiaio moka, mokkalöffel | 0/12/120/1800/9000 | 60 | 97,5 | 1,7 |  |
| N | 4942 CUCHARA ARROZ vintage rice spoon, cuillère à riz, cucchiaio riso, reislöffel | 0/12/120/1680/6720 | 60 | 90 | 2,5 | |
| O | 4943 TENEDOR RASTRILLO vintage wide fork, fourchette râteau, forchetta wide, taffelgabel wide | 0/12/120/1680/6720 | 60 | 113 | 2,5 | |
| 4945 | 24 PIEZAS 24 pieces, écrin 24 pièces, bauletto 24 pz., 24 stück | 1/0/4 | 4 | | 3 |  |

INOX STAINLESS STEEL 430

| | | UE | MOQ | ▶ mm | ✂ mm | |
|-------------|---|--------------------|-----|-------|------|---|
| A | 7277 CUCHILLO MESA XL table knife xl vintage, couteau table xl vintage, coltello tavola xl vintage, tafelmesser xl vintage | 0/12/120/2880/5760 | 60 | 212 | | |
| B | 7280 CUCHARA MESA XL table spoon xl vintage, cuillère table xl vintage, cucchiaio tavola xl vintage, tafelöffel xl vintage | 0/12/120/2880/5760 | 60 | 190 | 3 | |
| C | 7286 TENEDOR MESA 3 PUAS XL table fork 3 prongs xl vintage, fourchette table xl 3 dents vintage, forchetta tavola xl 3 punte vintage, tafelgabel xl vintage | 0/12/120/2880/5760 | 60 | 195 | 3 | |
| D | 7069 CUCHILLO MESA vintage table knife, couteau table vintage, coltello tavola vintage, tafelmesser vintage | 0/12/120/1800/9000 | 60 | 183 | | |
| E | 7070 CUCHARA MESA vintage table spoon, cuillère table vintage, cucchiaio tavola vintage, tafelöffel vintage | 0/12/120/1800/9000 | 60 | 170 | 2,5 | |
| F | 7071 TENEDOR MESA 2 PUAS vintage table fork 2 prongs, fourchette table 2 dents vintage, forchetta tavola 2 punte, tafelgabel 2 | 0/12/120/1800/9000 | 60 | 179 | 2,5 | |
| G | 7072 TENEDOR MESA 3 PUAS vintage table fork 3 prongs, fourchette table 3 dents vintage, forchetta tavola 3 punte, tafelgabel 3 | 0/12/120/1800/9000 | 60 | 163 | 2,5 | |
| H | 7073 CUCHILLO MANTEQUILLA vintage butter knife, couteau beurre, coltello burro, buttermesser | 0/12/120/1800/9000 | 60 | 155 | | |
| I | 7074 CUCHILLO LUNCH vintage cake knife, couteau gâteau, coltello dolce, kuchenmesser | 0/12/120/1800/9000 | 60 | 133 | | |
| J | 7075 TENEDOR LUNCH vintage cake fork, fourchette gâteau, forchetta dolce, kuchengabel | 0/12/120/1800/9000 | 60 | 138 | 2 | |
| K | 7076 CUCHARA CAFÉ vintage coffee spoon, cuillère café, cucchiaio caffè, kaffeelöffel | 0/12/120/1800/9000 | 60 | 115,4 | 1,7 | |
| L | 7077 CUCHARA SIDE vintage side spoon, cuillère side, cucchiaio side, löffel side | 0/12/120/1800/9000 | 60 | 93,5 | 2 | |
| M | 7078 CUCHARA MOKA vintage moka spoon, cuillère moka, cucchiaio moka, mokkalöffel | 0/12/120/1800/9000 | 60 | 97,5 | 1,7 |  |
| N | 7079 CUCHARA ARROZ vintage rice spoon, cuillère à riz, cucchiaio riso, reislöffel | 0/12/120/1680/6720 | 60 | 90 | 2,5 | |
| O | 7080 TENEDOR RASTRILLO vintage wide fork, fourchette râteau, forchetta wide, taffelgabel wide | 0/12/120/1680/6720 | 60 | 113 | 2,5 | |
| 9795 | 24 PIEZAS 24 pieces, écrin 24 pièces, bauletto 24 pz., 24 stück | 1/0/4 | 4 | | 3 |  |

Mini Kodai

Mini Kodai
Servicio mesa / Table top



Gama de miniaturas pensada en combinar la colección Kodai para crear el conjunto perfecto en la mesa y disfrutar de una experiencia completa al degustar un aperitivo o unas tapas.

Miniatures range designed to combine Kodai collection and create a perfect set on a table and enjoy a complete experience on tasting a snack or "tapas".





Mini Kodai

Servicio mesa / Table Top



Mini vaso
Mini cup
Mini verre
Mini vaso
Dipschälchen klein



| REF. | Ø(mm) | H(mm) | ml | € | UE / MOQ |
|------|-------|-------|-----|---|-----------------------|
| 7625 | 50 | 40 | 2,5 | | 1-6-144-2592-2592 / 6 |

Mini tarrina
Mini ramekin
Mini pôt
Mini terrina
Dipschälchen groß



| REF. | Ø(mm) | H(mm) | € | UE / MOQ |
|------|-------|-------|---|-----------------------|
| 7626 | 80 | 25 | | 1-6-144-1728-1728 / 6 |

Mini sartén
Mini pan
Mini poêle
Mini padella
Mini pfanne



| REF. | Ø(mm) | L(mm) | H(mm) | € | UE / MOQ |
|------|-------|-------|-------|---|---------------------|
| 7627 | 90 | 140 | 22 | | 1-6-72-360-1080 / 6 |

Mini bandeja
Mini tray
Mini plateau
Mini vassoio
Mini platte



| REF. | W(mm) | L(mm) | H(mm) | € | UE / MOQ |
|------|-------|-------|-------|---|---------------------|
| 7629 | 80 | 155 | 10 | | 1-6-72-360-1080 / 6 |

Mini caja M
Mini box M
Mini Boîte M
Mini Cassetta M
Behälter M



| REF. | W(mm) | L(mm) | H(mm) | € | UE / MOQ |
|------|-------|-------|-------|---|---------------------|
| 7621 | 80 | 120 | 70 | | 1-6-36-360-1080 / 6 |

Mini parrilla
Mini grill plate
Mini grill
Mini graticola
Mini gratin platte



| REF. | Ø(mm) | L(mm) | H(mm) | € | UE / MOQ |
|------|-------|-------|-------|---|-----------------------|
| 7624 | 90 | 125 | 20 | | 1-6-144-1728-1728 / 6 |

Mini cazuela
Mini casserole
Mini casserole
Mini casseruola
Mini kasserolle



| REF. | Ø(mm) | L(mm) | H(mm) | € | UE / MOQ |
|------|-------|-------|-------|---|---------------------|
| 7628 | 90 | 130 | 25 | | 1-6-72-360-1080 / 6 |

Mini olla
Mini pot
Mini-pot
Mini pentola
Mini topf



| REF. | Ø(mm) | L(mm) | H(mm) | ml | € | UE / MOQ |
|------|-------|-------|-------|-----|---|---------------------|
| 7630 | 100 | 140 | 90 | 250 | | 1-6-36-360-1080 / 6 |

Fleur de Lys



INOX 18/10 / 4,5mm / Mirror

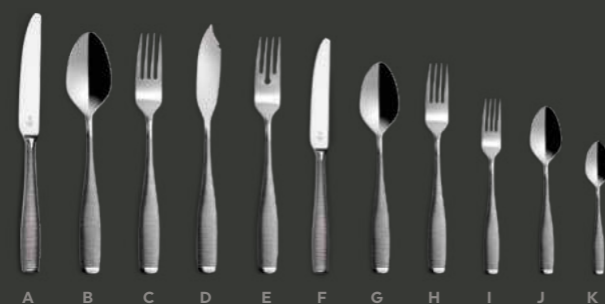

Fleur de Lys

INOX 18/10 / 4,5mm / Mirror



INOX
STAINLESS
STEEL
304

- A **7980** CUCHILLO MESA
table knife, couteau table, coltello tavola, tafelmesser
- B **7981** CUCHARA MESA
table spoon, cuillère table, cucchiaio tavola, tafellöffel
- C **7982** TENEDOR MESA
table fork, fourchette table, forchetta tavola, tafelgabel
- D **8007** PALA PESCADO
fish knife, couteau poisson, coltello pesce, fischmesser
- E **8008** TENEDOR PESCADO
fish fork, fourchette poisson, forchetta pesce, fischgabel
- F **7983** CUCHILLO POSTRE
dessert knife, couteau dessert, coltello frutta, dessertmesser
- G **7984** CUCHARA POSTRE
dessert spoon, cuillère dessert, cucchiaio frutta, dessertlöffel
- H **7985** TENEDOR POSTRE
dessert fork, fourchette dessert, forchetta frutta, dessertgabel
- I **7986** TENEDOR LUNCH
cake fork, fourchette gâteau, forchetta dolce, kuchengabel
- J **7987** CUCHARA CAFÉ
tea spoon, cuillère café, cucchiaio caffè, kaffeelöffel
- K **7988** CUCHARA MOKA
coffee/moka spoon, cuillère moka, cucchiaio moka, mokkalöffel

- 7989** 24 PIEZAS
24 pieces, écriin 24 pièces, bauletto 24 pz., 24 stück

| UE | MOQ | ▶ mm | ✕ mm |
|---------------------|-----|------|------|
| 0/12/120/1920/5760 | 60 | 235 | |
| 0/12/120/1440/7200 | 60 | 215 | 4,5 |
| 0/12/120/1440/7200 | 60 | 214 | 4,5 |
| 0/12/120/1440/7200 | 60 | 221 | 4,5 |
| 0/12/120/1440/7200 | 60 | 210 | 4,5 |
| 0/12/120/1920/5760 | 60 | 208 | |
| 0/12/120/1440/7200 | 60 | 189 | 4 |
| 0/12/120/1440/7200 | 60 | 186 | 4 |
| 0/12/120/2520/15120 | 60 | 156 | 3 |
| 0/12/120/2520/15120 | 60 | 150 | 3 |
| 0/12/120/2520/15120 | 60 | 118 | 2,5 |
| 1/0/4 | 4 | | 4,5 |



Fleur de Lys Vintage Black



INOX 18/10 / 4,5mm / Vintage Black



A B C D E F G H I J K

Fleur de Lys Vintage Black

INOX 18/10 / 4,5mm / Vintage Black



INOX
STAINLESS
STEEL
304

| | | |
|---|-------------|--|
| A | 6962 | CUCHILLO MESA table knife, couteau table, coltello tavola, tafelmesser |
| B | 6963 | CUCHARA MESA table spoon, cuillère table, cucchiaio tavola, tafellöffel |
| C | 6964 | TENEDOR MESA table fork, fourchette table, forchetta tavola, tafelgabel |
| D | 6965 | PALA PESCADO fish knife, couteau poisson, coltello pesce, fischmesser |
| E | 6966 | TENEDOR PESCADO fish fork, fourchette poisson, forchetta pesce, fischgabel |
| F | 6967 | CUCHILLO POSTRE dessert knife, couteau dessert, coltello frutta, dessertmesser |
| G | 6968 | CUCHARA POSTRE dessert spoon, cuillère dessert, cucchiaio frutta, dessertlöffel |
| H | 6969 | TENEDOR POSTRE dessert fork, fourchette dessert, forchetta frutta, dessertgabel |
| I | 6970 | TENEDOR LUNCH cake fork, fourchette gâteau, forchetta dolce, kuchengabel |
| J | 6971 | CUCHARA CAFÉ tea spoon, cuillère café, cucchiaio caffè, kaffeelöffel |
| K | 6972 | CUCHARA MOKA coffee/moka spoon, cuillère moka, cucchiaio moka, mokkalöffel |

6973 24 PIEZAS
24 pieces, écrin 24 pièces, bauletto 24 pz., 24 stück

| UE | MOQ | ▶ mm | ✂ mm |
|---------------------|-----|------|------|
| 0/12/120/1920/5760 | 60 | 235 | |
| 0/12/120/1440/7200 | 60 | 215 | 4,5 |
| 0/12/120/1440/7200 | 60 | 214 | 4,5 |
| 0/12/120/1440/7200 | 60 | 221 | 4,5 |
| 0/12/120/1440/7200 | 60 | 210 | 4,5 |
| 0/12/120/1920/5760 | 60 | 208 | |
| 0/12/120/1440/7200 | 60 | 189 | 4 |
| 0/12/120/1440/7200 | 60 | 186 | 4 |
| 0/12/120/2520/15120 | 60 | 156 | 3 |
| 0/12/120/2520/15120 | 60 | 150 | 3 |
| 0/12/120/2520/15120 | 60 | 118 | 2,5 |
| 1/0/4 | 4 | | 4,5 |



Oslo

INOX 18/10 / 7mm / Mirror / FORGED



INOX STAINLESS STEEL 304

| | | |
|---|-------------|--|
| A | 3619 | CUCHILLO CHULETERO steak knife, couteau steak, coltello bistecca, steakmesser |
| B | 5474 | CUCHILLO MESA table knife, couteau table, coltello tavola, tafelmesser |
| C | 5475 | CUCHARA MESA table spoon, cuillère table, cucchiaio tavola, tafellöffel |
| D | 5476 | TENEDOR MESA table fork, fourchette table, forchetta tavola, tafelgabel |
| E | 5483 | PALA PESCADO fish knife, couteau poisson, coltello pesce, fischmesser |
| F | 5484 | TENEDOR PESCADO fish fork, fourchette poisson, forchetta pesce, fischgabel |
| G | 2171 | CUCHILLO POSTRE dessert knife, couteau dessert, coltello frutta, dessertmesser |
| H | 5485 | CUCHARA POSTRE dessert spoon, cuillère dessert, cucchiaio frutta, dessertlöffel |
| I | 5486 | TENEDOR POSTRE dessert fork, fourchette dessert, forchetta frutta, dessertgabel |
| J | 5478 | TENEDOR LUNCH cake fork, fourchette gâteau, forchetta dolce, kuchengabel |
| K | 5477 | CUCHARA CAFÉ tea spoon, cuillère café, cucchiaio caffè, kaffeelöffel |
| L | 5479 | CUCHARA MOKA coffee/moka spoon, cuillère moka, cucchiaio moka, mokkalöffel |

1600 24 PIEZAS
24 pieces, écriin 24 pièces, bauletto 24 pz., 24 stück

NEW



La colección OSLO OCEAN FREE ha sido producida con NYLON que provienen del plástico recuperado y reciclado. Este material, que constituye una parte significativa de los desechos plásticos en el océano, se recolecta, limpia y recicla mediante procesos avanzados para transformarlo en materias primas reutilizables.

Su fabricación supone una reducción de la huella de carbono y reduce el impacto sobre el medio ambiente frente a otros materiales.

INOX STAINLESS STEEL 430

| | | |
|---|--------------|--|
| A | 12024 | CUCHILLO MESA table knife, couteau table, coltello tavola, tafelmesser |
| B | 12025 | CUCHARA MESA table spoon, cuillère table, cucchiaio tavola, tafellöffel |
| C | 12026 | TENEDOR MESA table fork, fourchette table, forchetta tavola, tafelgabel |
| D | 12027 | CUCHARA CAFÉ tea spoon, cuillère café, cucchiaio caffè, kaffeelöffel |

12028 24 PIEZAS
24 pieces, écriin 24 pièces, bauletto 24 pz., 24 stück

Oslo Ocean Free

INOX 18/10 / 4mm / Satin / Nylon



The OSLO OCEAN FREE collection has been produced with NYLON from recovered and recycled plastic. This material, which constitutes a significant portion of the plastic waste in the ocean, is collected, cleaned, and recycled through advanced processes to transform it into reusable raw materials.

In addition, its manufacture reduces the carbon footprint and reduces the impact on the environment compared to other materials.

| | | | |
|---------------------|------------|-------------|-------------|
| UE | MOQ | ▶ mm | ✂ mm |
| 0/12/120/1920/5760 | 60 | 226 | 0 |
| 0/12/120/1440/7200 | 60 | 210 | 4 |
| 0/12/120/1440/7200 | 60 | 210 | 4 |
| 0/12/120/2520/15120 | 60 | 150 | 3,5 |
| 1/0/4/56/112 | 4 | | 4 |

Dalia

INOX 18/10 / 8,5mm / Mirror / Forged



INOX STAINLESS STEEL 304

| | | |
|---|-------------|---|
| A | 7057 | CUCHILLO MESA table knife, couteau table, coltello tavola, tafelmesser |
| B | 7058 | CUCHARA MESA table spoon, cuillère table, cucchiaio tavola, tafellöffel |
| C | 7059 | TENEDOR MESA table fork, fourchette table, forchetta tavola, tafelgabel |
| D | 7060 | CUCHILLO POSTRE dessert knife, couteau dessert, coltello frutta, dessertmesser |
| E | 7061 | CUCHARA POSTRE dessert spoon, cuillère dessert, cucchiaio frutta, dessertlöffel |
| F | 7062 | TENEDOR POSTRE dessert fork, fourchette dessert, forchetta frutta, dessertgabel |
| G | 7063 | TENEDOR LUNCH cake fork, fourchette gâteau, forchetta dolce, kuchengabel |
| H | 7064 | CUCHARA CAFÉ/TE coffee/iced tea spoon, cuillère café/té, cucchiaio caffè/the, cocktaillöffel |
| I | 7065 | CUCHARA MOKA coffee/moka spoon, cuillère moka, cucchiaio moka, mokkalöffel |

| UE | MOQ | mm | mm |
|---------------------|-----|-----|-----|
| 0/12/120/1920/5760 | 60 | 234 | |
| 0/12/120/1440/7200 | 60 | 205 | 8,5 |
| 0/12/120/1440/7200 | 60 | 204 | 8,5 |
| 0/12/120/1920/5760 | 60 | 210 | |
| 0/12/120/1440/7200 | 60 | 182 | 7,5 |
| 0/12/120/1440/7200 | 60 | 181 | 7,5 |
| 0/12/120/2520/15120 | 60 | 156 | 6,4 |
| 0/12/120/2520/15120 | 60 | 154 | 6,4 |
| 0/12/120/2520/15120 | 60 | 108 | 4,5 |
| 1/0/4 | 4 | | 8,5 |



Iris

INOX 18/10 / 6mm / Mirror

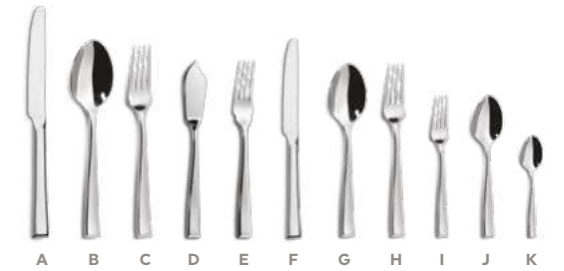

INOX STAINLESS STEEL 304

| | | |
|---|-------------|--|
| A | 7022 | CUCHILLO MESA table knife, couteau table, coltello tavola, tafelmesser |
| B | 7023 | CUCHARA MESA table spoon, cuillère table, cucchiaio tavola, tafellöffel |
| C | 7024 | TENEDOR MESA table fork, fourchette table, forchetta tavola, tafelgabel |
| D | 7025 | PALA PESCADO fish knife, couteau poisson, coltello pesce, fischmesser |
| E | 7026 | TENEDOR PESCADO fish fork, fourchette poisson, forchetta pesce, fischgabel |
| F | 7027 | CUCHILLO POSTRE dessert knife, couteau dessert, coltello frutta, dessertmesser |
| G | 7028 | CUCHARA POSTRE dessert spoon, cuillère dessert, cucchiaio frutta, dessertlöffel |
| H | 7029 | TENEDOR POSTRE dessert fork, fourchette dessert, forchetta frutta, dessertgabel |
| I | 7030 | TENEDOR LUNCH cake fork, fourchette gâteau, forchetta dolce, kuchengabel |
| J | 7031 | CUCHARA CAFÉ tea spoon, cuillère café, cucchiaio caffè, kaffeelöffel |
| K | 7032 | CUCHARA MOKA coffee/moka spoon, cuillère moka, cucchiaio moka, mokkalöffel |

| UE | MOQ | mm | mm |
|---------------------|-----|-----|-----|
| 0/12/120/1920/5760 | 60 | 243 | 8 |
| 0/12/120/1440/7200 | 60 | 209 | 6 |
| 0/12/120/1440/7200 | 60 | 209 | 6 |
| 0/12/120/1440/7200 | 60 | 188 | 5 |
| 0/12/120/1440/7200 | 60 | 188 | 5 |
| 0/12/120/1920/5760 | 60 | 210 | 7 |
| 0/12/120/1440/7200 | 60 | 184 | 5 |
| 0/12/120/1440/7200 | 60 | 184 | 5 |
| 0/12/120/2520/15120 | 60 | 151 | 4,5 |
| 0/12/120/2520/15120 | 60 | 151 | 4,5 |
| 0/12/120/2520/15120 | 60 | 108 | 4 |
| 1/0/4 | 4 | | 6 |



Callas

INOX 18/10 / 3,5mm / Mirror

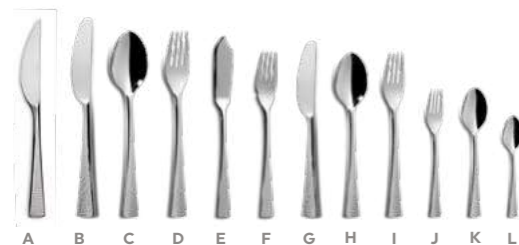

Sangiovese

INOX 18/10 / 3,5mm / Mirror

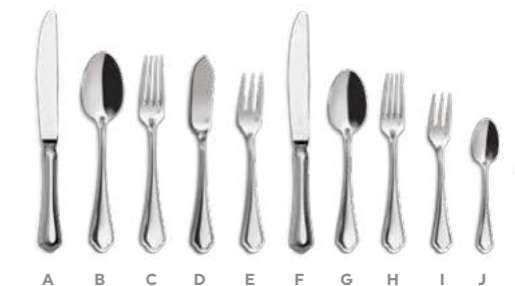

INOX
STAINLESS
STEEL
304

| | UE | MOQ | ▶ mm | ✂ mm |
|--|---------------------|-----|------|------|
| A 7010 CUCHILLO CHULETERO steak knife, couteau steak, coltello bistecca, steakmesser | 0/12/120/1920/5760 | 60 | 225 | 7 |
| B 7011 CUCHILLO MESA table knife, couteau table, coltello tavola, tafelmesser | 0/12/120/1920/5760 | 60 | 225 | 7 |
| C 7012 CUCHARA MESA table spoon, cuillère table, cucchiaio tavola, tafellöffel | 0/12/120/1440/7200 | 60 | 215 | 3,5 |
| D 7013 TENEDOR MESA table fork, fourchette table, forchetta tavola, tafelgabel | 0/12/120/1440/7200 | 60 | 212 | 3,5 |
| E 7014 PALA PESCADO fish knife, couteau poisson, coltello pesce, fischmesser | 0/12/120/1440/7200 | 60 | 205 | 3 |
| F 7015 TENEDOR PESCADO fish fork, fourchette poisson, forchetta pesce, fischgabel | 0/12/120/1440/7200 | 60 | 188 | 3 |
| G 7016 CUCHILLO POSTRE dessert knife, couteau dessert, coltello frutta, dessertmesser | 0/12/120/1920/5760 | 60 | 203 | 6 |
| H 7017 CUCHARA POSTRE dessert spoon, cuillère dessert, cucchiaio frutta, dessertlöffel | 0/12/120/1440/7200 | 60 | 185 | 3 |
| I 7018 TENEDOR POSTRE dessert fork, fourchette dessert, forchetta frutta, dessertgabel | 0/12/120/1440/7200 | 60 | 185 | 3 |
| J 7019 TENEDOR LUNCH cake fork, fourchette gâteau, forchetta dolce, kuchengabel | 0/12/120/2520/15120 | 60 | 145 | 2,5 |
| K 7020 CUCHARA CAFÉ tea spoon, cuillère café, cucchiaio caffè, kaffeelöffel | 0/12/120/2520/15120 | 60 | 147 | 2,5 |
| L 7021 CUCHARA MOKA coffee/moka spoon, cuillère moka, cucchiaio moka, mokkalöffel | 0/12/120/2520/15120 | 60 | 115 | 2 |

5964 24 PIEZAS
24 pieces, écriin 24 pièces, bauletto 24 pz., 24 stück

INOX
STAINLESS
STEEL
304

| | UE | MOQ | ▶ mm | ✂ mm |
|--|---------------------|-----|------|------|
| A 6895 CUCHILLO MESA table knife, couteau table, coltello tavola, tafelmesser | 0/12/120/1920/5760 | 60 | 255 | |
| B 6896 CUCHARA MESA table spoon, cuillère table, cucchiaio tavola, tafellöffel | 0/12/120/1440/7200 | 60 | 209 | 3,5 |
| C 6897 TENEDOR MESA table fork, fourchette table, forchetta tavola, tafelgabel | 0/12/120/1440/7200 | 60 | 209 | 3,5 |
| D 6898 PALA PESCADO fish knife, couteau poisson, coltello pesce, fischmesser | 0/12/120/1440/7200 | 60 | 208 | 3 |
| E 6899 TENEDOR PESCADO fish fork, fourchette poisson, forchetta pesce, fischgabel | 0/12/120/1440/7200 | 60 | 190 | 3 |
| F 6900 CUCHILLO POSTRE dessert knife, couteau dessert, coltello frutta, dessertmesser | 0/12/120/1920/5760 | 60 | 232 | |
| G 6901 CUCHARA POSTRE dessert spoon, cuillère dessert, cucchiaio frutta, dessertlöffel | 0/12/120/1440/7200 | 60 | 190 | 3 |
| H 6902 TENEDOR POSTRE dessert fork, fourchette dessert, forchetta frutta, dessertgabel | 0/12/120/1440/7200 | 60 | 190 | 3 |
| I 6903 TENEDOR LUNCH cake fork, fourchette gâteau, forchetta dolce, kuchengabel | 0/12/120/2520/15120 | 60 | 170 | 3 |
| J 6904 CUCHARA CAFÉ tea spoon, cuillère café, cucchiaio caffè, kaffeelöffel | 0/12/120/2520/15120 | 60 | 142 | 3 |
| K 6905 CUCHARA MOKA coffee/moka spoon, cuillère moka, cucchiaio moka, mokkalöffel | 0/12/120/2520/15120 | 60 | 111 | 2 |

6906 24 PIEZAS
24 pieces, écriin 24 pièces, bauletto 24 pz., 24 stück

| | UE | MOQ | ▶ mm | ✂ mm |
|--|---------------------|-----|------|------|
| A 6895 CUCHILLO MESA table knife, couteau table, coltello tavola, tafelmesser | 0/12/120/1920/5760 | 60 | 255 | |
| B 6896 CUCHARA MESA table spoon, cuillère table, cucchiaio tavola, tafellöffel | 0/12/120/1440/7200 | 60 | 209 | 3,5 |
| C 6897 TENEDOR MESA table fork, fourchette table, forchetta tavola, tafelgabel | 0/12/120/1440/7200 | 60 | 209 | 3,5 |
| D 6898 PALA PESCADO fish knife, couteau poisson, coltello pesce, fischmesser | 0/12/120/1440/7200 | 60 | 208 | 3 |
| E 6899 TENEDOR PESCADO fish fork, fourchette poisson, forchetta pesce, fischgabel | 0/12/120/1440/7200 | 60 | 190 | 3 |
| F 6900 CUCHILLO POSTRE dessert knife, couteau dessert, coltello frutta, dessertmesser | 0/12/120/1920/5760 | 60 | 232 | |
| G 6901 CUCHARA POSTRE dessert spoon, cuillère dessert, cucchiaio frutta, dessertlöffel | 0/12/120/1440/7200 | 60 | 190 | 3 |
| H 6902 TENEDOR POSTRE dessert fork, fourchette dessert, forchetta frutta, dessertgabel | 0/12/120/1440/7200 | 60 | 190 | 3 |
| I 6903 TENEDOR LUNCH cake fork, fourchette gâteau, forchetta dolce, kuchengabel | 0/12/120/2520/15120 | 60 | 170 | 3 |
| J 6904 CUCHARA CAFÉ tea spoon, cuillère café, cucchiaio caffè, kaffeelöffel | 0/12/120/2520/15120 | 60 | 142 | 3 |
| K 6905 CUCHARA MOKA coffee/moka spoon, cuillère moka, cucchiaio moka, mokkalöffel | 0/12/120/2520/15120 | 60 | 111 | 2 |

6906 24 PIEZAS
24 pieces, écriin 24 pièces, bauletto 24 pz., 24 stück

Sangiovese Gold

INOX 18/10 / 3,5mm / Mirror



Sangiovese Vintage Copper

INOX 18/10 / 3,5mm / Vintage



INOX
STAINLESS
STEEL
304

- A **7271** CUCHILLO MESA
table knife, couteau table, coltello tavola, tafelmesser
- B **7418** CUCHARA MESA
table spoon, cuillère table, cucchiaio tavola, tafellöffel
- C **7272** TENEDOR MESA
table fork, fourchette table, forchetta tavola, tafelgabel
- D **7420** CUCHILLO POSTRE
dessert knife, couteau dessert, coltello frutta, dessertmesser
- E **7419** CUCHARA POSTRE
dessert spoon, cuillère dessert, cucchiaio frutta, dessertlöffel
- F **7273** TENEDOR POSTRE
dessert fork, fourchette dessert, forchetta frutta, dessertgabel
- G **7957** TENEDOR LUNCH
cake fork, fourchette gâteau, forchetta dolce, kuchengabel
- H **7274** CUCHARA CAFÉ
tea spoon, cuillère café, cucchiaio caffè, kaffeelöffel
- I **7275** CUCHARA MOKA
coffee/moka spoon, cuillère moka, cucchiaio moka, mokkalöffel

5554 24 PIEZAS
24 pieces, écrin 24 pièces, bauletto 24 pz., 24 stück

| UE | MOQ | ✦ mm | ✦ mm |
|---------------------|-----|------|------|
| 0/12/120/1920/5760 | 60 | 255 | |
| 0/12/120/1440/7200 | 60 | 209 | 3,5 |
| 0/12/120/1440/7200 | 60 | 209 | 3,5 |
| 0/12/120/1920/5760 | 60 | 232 | |
| 0/12/120/1440/7200 | 60 | 190 | 3 |
| 0/12/120/1440/7200 | 60 | 190 | 3 |
| 0/12/120/2520/15120 | 60 | 170 | 3 |
| 0/12/120/2520/15120 | 60 | 142 | 3 |
| 0/12/120/2520/15120 | 60 | 111 | 2 |



INOX
STAINLESS
STEEL
304

- A **5763** CUCHILLO MESA
table knife, couteau table, coltello tavola, tafelmesser
- B **5764** CUCHARA MESA
table spoon, cuillère table, cucchiaio tavola, tafellöffel
- C **7737** TENEDOR MESA
table fork, fourchette table, forchetta tavola, tafelgabel
- D **5765** CUCHILLO POSTRE
dessert knife, couteau dessert, coltello frutta, dessertmesser
- E **5766** CUCHARA POSTRE
dessert spoon, cuillère dessert, cucchiaio frutta, dessertlöffel
- F **5767** TENEDOR POSTRE
dessert fork, fourchette dessert, forchetta frutta, dessertgabel
- G **5768** TENEDOR LUNCH
cake fork, fourchette gâteau, forchetta dolce, kuchengabel
- H **5769** CUCHARA CAFÉ
tea spoon, cuillère café, cucchiaio caffè, kaffeelöffel
- I **5770** CUCHARA MOKA
coffee/moka spoon, cuillère moka, cucchiaio moka, mokkalöffel

5557 24 PIEZAS
24 pieces, écrin 24 pièces, bauletto 24 pz., 24 stück

| UE | MOQ | ✦ mm | ✦ mm |
|---------------------|-----|------|------|
| 0/12/120/1920/5760 | 60 | 255 | |
| 0/12/120/1440/7200 | 60 | 209 | 3,5 |
| 0/12/120/1440/7200 | 60 | 209 | 3,5 |
| 0/12/120/1920/5760 | 60 | 232 | |
| 0/12/120/1440/7200 | 60 | 190 | 3 |
| 0/12/120/1440/7200 | 60 | 190 | 3 |
| 0/12/120/2520/15120 | 60 | 170 | 3 |
| 0/12/120/2520/15120 | 60 | 142 | 3 |
| 0/12/120/2520/15120 | 60 | 111 | 2 |





INOX 18/10 / 4mm / Mirror



BAJO PEDIDO
ON DEMAND

- A **6525** CUCHILLO MESA
table knife, couteau table, coltello tavola, tafelmesser
- B **6526** CUCHARA MESA
table spoon, cuillère table, cucchiaio tavola, tafellöffel
- C **6527** TENEDOR MESA
table fork, fourchette table, forchetta tavola, tafelgabel
- D **6528** PALA PESCADO
fish knife, couteau poisson, coltello pesce, fischmesser
- E **6529** TENEDOR PESCADO
fish fork, fourchette poisson, forchetta pesce, fischgabel
- F **6530** CUCHILLO POSTRE
dessert knife, couteau dessert, coltello frutta, dessertmesser
- G **6531** CUCHARA POSTRE
dessert spoon, cuillère dessert, cucchiaio frutta, dessertlöffel
- H **6532** TENEDOR POSTRE
dessert fork, fourchette dessert, forchetta frutta, dessertgabel
- I **6533** TENEDOR LUNCH
cake fork, fourchette gâteau, forchetta dolce, kuchengabel
- J **6534** CUCHARA CAFÉ
tea spoon, cuillère café, cucchiaio caffè, kaffeelöffel
- K **6535** CUCHARA MOKA
coffee/moka spoon, cuillère moka, cucchiaio moka, mokkalöffel

6536 24 PIEZAS
24 pieces, écrin 24 pièces, bauletto 24 pz., 24 stück

| UE | MOQ | ▶ mm | ✕ mm |
|---------------------|-----|------|------|
| 0/12/120/1920/5760 | 60 | 238 | |
| 0/12/120/1440/7200 | 60 | 213 | 4 |
| 0/12/120/1440/7200 | 60 | 213 | 4 |
| 0/12/120/1440/7200 | 60 | 224 | 4 |
| 0/12/120/1440/7200 | 60 | 200 | 4 |
| 0/12/120/1920/5760 | 60 | 216 | |
| 0/12/120/1440/7200 | 60 | 192 | 3,5 |
| 0/12/120/1440/7200 | 60 | 192 | 3,5 |
| 0/12/120/2520/15120 | 60 | 140 | 3 |
| 0/12/120/2520/15120 | 60 | 140 | 3 |
| 0/12/120/2520/15120 | 60 | 115 | 2,5 |
| 1/0/4 | 4 | | 4 |





INOX
STAINLESS
STEEL
304

INOX 18/10 / 4mm / Mirror

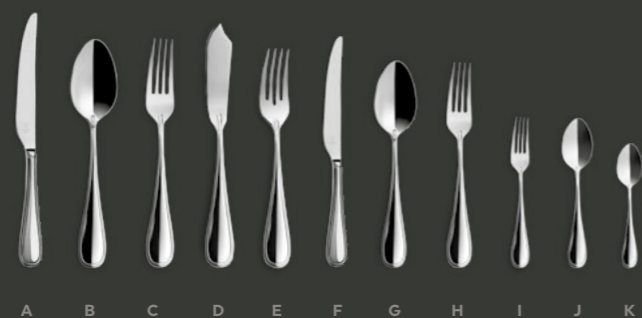

A B C D E F G H I J K

- A **7968** CUCHILLO MESA
table knife, couteau table, coltello tavola, tafelmesser
- B **7969** CUCHARA MESA
table spoon, cuillère table, cucchiaio tavola, tafellöffel
- C **7970** TENEDOR MESA
table fork, fourchette table, forchetta tavola, tafelgabel
- D **7971** PALA PESCADO
fish knife, couteau poisson, coltello pesce, fischmesser
- E **7972** TENEDOR PESCADO
fish fork, fourchette poisson, forchetta pesce, fischgabel
- F **7973** CUCHILLO POSTRE
dessert knife, couteau dessert, coltello frutta, dessertmesser
- G **7974** CUCHARA POSTRE
dessert spoon, cuillère dessert, cucchiaio frutta, dessertlöffel
- H **7975** TENEDOR POSTRE
dessert fork, fourchette dessert, forchetta frutta, dessertgabel
- I **7976** TENEDOR LUNCH
cake fork, fourchette gâteau, forchetta dolce, kuchengabel
- J **7977** CUCHARA CAFÉ
tea spoon, cuillère café, cucchiaio caffè, kaffeelöffel
- K **7978** CUCHARA MOKA
coffee/moka spoon, cuillère moka, cucchiaio moka, mokkalöffel

- 7979** 24 PIEZAS
24 pieces, écriin 24 pièces, bauletto 24 pz., 24 stück

| UE | MOQ | ◀ mm | ✂ mm |
|--------------------|-----|------|------|
| 0/12/60/1920/5760 | 60 | 238 | |
| 0/12/60/1440/7200 | 60 | 213 | 4 |
| 0/12/60/1440/7200 | 60 | 213 | 4 |
| 0/12/60/1440/7200 | 60 | 224 | 4 |
| 0/12/60/1440/7200 | 60 | 200 | 4 |
| 0/12/60/1920/5760 | 60 | 216 | |
| 0/12/60/1440/7200 | 60 | 192 | 3,5 |
| 0/12/60/1440/7200 | 60 | 192 | 3,5 |
| 0/12/60/2520/15120 | 60 | 140 | 3 |
| 0/12/60/2520/15120 | 60 | 140 | 3 |
| 0/12/60/2520/15120 | 60 | 115 | 2,5 |
| 1/0/4 | 4 | | 4 |



Contour Vintage Gold

INOX 18/10 / 4mm / Vintage

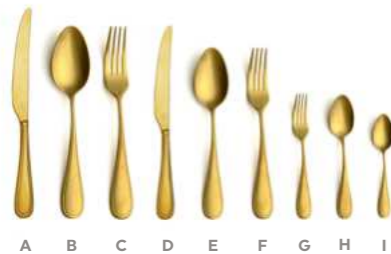

Contour Vintage Copper

INOX 18/10 / 4mm / Vintage

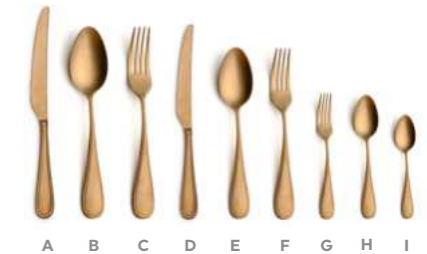

INOX
STAINLESS
STEEL
304

- A **5783** CUCHILLO MESA
table knife, couteau table, coltello tavola, tafelmesser
- B **5784** CUCHARA MESA
table spoon, cuillère table, cucchiaio tavola, tafellöffel
- C **5785** TENEDOR MESA
table fork, fourchette table, forchetta tavola, tafelgabel
- D **5786** CUCHILLO POSTRE
dessert knife, couteau dessert, coltello frutta, dessertmesser
- E **5787** CUCHARA POSTRE
dessert spoon, cuillère dessert, cucchiaio frutta, dessertlöffel
- F **5788** TENEDOR POSTRE
dessert fork, fourchette dessert, forchetta frutta, dessertgabel
- G **5789** TENEDOR LUNCH
cake fork, fourchette gâteau, forchetta dolce, kuchengabel
- H **5790** CUCHARA CAFÉ
tea spoon, cuillère café, cucchiaio caffè, kaffeelöffel
- I **5791** CUCHARA MOKA
coffee/moka spoon, cuillère moka, cucchiaio moka, mokkalöffel

5792 24 PIEZAS
24 pieces, écriin 24 pièces, bauletto 24 pz., 24 stück

| UE | MOQ | ▶ mm | ✂ mm |
|--------------------|-----|------|------|
| 0/12/60/1920/5760 | 60 | 238 | |
| 0/12/60/1440/7200 | 60 | 213 | 4 |
| 0/12/60/1440/7200 | 60 | 213 | 4 |
| 0/12/60/1920/5760 | 60 | 216 | |
| 0/12/60/1440/7200 | 60 | 192 | 3,5 |
| 0/12/60/1440/7200 | 60 | 192 | 3,5 |
| 0/12/60/2520/15120 | 60 | 140 | 3 |
| 0/12/60/2520/15120 | 60 | 140 | 3 |
| 0/12/60/2520/15120 | 60 | 115 | 2,5 |



INOX
STAINLESS
STEEL
304

**BAJO PEDIDO
ON DEMAND**

- A **5771** CUCHILLO MESA
table knife, couteau table, coltello tavola, tafelmesser
- B **5772** CUCHARA MESA
table spoon, cuillère table, cucchiaio tavola, tafellöffel
- C **5773** TENEDOR MESA
table fork, fourchette table, forchetta tavola, tafelgabel
- D **5774** CUCHILLO POSTRE
dessert knife, couteau dessert, coltello frutta, dessertmesser
- E **5775** CUCHARA POSTRE
dessert spoon, cuillère dessert, cucchiaio frutta, dessertlöffel
- F **5776** TENEDOR POSTRE
dessert fork, fourchette dessert, forchetta frutta, dessertgabel
- G **5777** TENEDOR LUNCH
cake fork, fourchette gâteau, forchetta dolce, kuchengabel
- H **5778** CUCHARA CAFÉ
tea spoon, cuillère café, cucchiaio caffè, kaffeelöffel
- I **5779** CUCHARA MOKA
coffee/moka spoon, cuillère moka, cucchiaio moka, mokkalöffel

5780 24 PIEZAS
24 pieces, écriin 24 pièces, bauletto 24 pz., 24 stück

| UE | MOQ | ▶ mm | ✂ mm |
|--------------------|-----|------|------|
| 0/12/60/1920/5760 | 60 | 238 | |
| 0/12/60/1440/7200 | 60 | 213 | 4 |
| 0/12/60/1440/7200 | 60 | 213 | 4 |
| 0/12/60/1920/5760 | 60 | 216 | |
| 0/12/60/1440/7200 | 60 | 192 | 3,5 |
| 0/12/60/1440/7200 | 60 | 192 | 3,5 |
| 0/12/60/2520/15120 | 60 | 140 | 3 |
| 0/12/60/2520/15120 | 60 | 140 | 3 |
| 0/12/60/2520/15120 | 60 | 115 | 2,5 |



Versailles Satin

INOX 18/10 / 3,5mm / Satin



INOX
STAINLESS
STEEL
304

- A **7765** CUCHILLO MESA
table knife, couteau table, coltello tavola, tafelmesser
- B **7766** CUCHARA MESA
table spoon, cuillère table, cucchiaio tavola, tafellöffel
- C **7767** TENEDOR MESA
table fork, fourchette table, forchetta tavola, tafelgabel
- D **7770** CUCHILLO POSTRE
dessert knife, couteau dessert, coltello frutta, dessertmesser
- E **7771** CUCHARA POSTRE
dessert spoon, cuillère dessert, cucchiaio frutta, dessertlöffel
- F **7772** TENEDOR POSTRE
dessert fork, fourchette dessert, forchetta frutta, dessertgabel
- G **7773** TENEDOR LUNCH
cake fork, fourchette gâteau, forchetta dolce, kuchengabel
- H **7774** CUCHARA CAFÉ
tea spoon, cuillère café, cucchiaio caffè, kaffeelöffel
- I **7775** CUCHARA MOKA
coffee/moka spoon, cuillère moka, cucchiaio moka, mokkalöffel

7776 24 PIEZAS
24 pieces, écriin 24 pièces, bauletto 24 pz., 24 stück

| UE | MOQ | ▶ mm | ✂ mm |
|--------------------|-----|------|------|
| 0/12/60/1920/5760 | 60 | 245 | |
| 0/12/60/1440/7200 | 60 | 210 | 3,5 |
| 0/12/60/1440/7200 | 60 | 210 | 3,5 |
| 0/12/60/1920/5760 | 60 | 220 | |
| 0/12/60/1440/7200 | 60 | 190 | 3 |
| 0/12/60/1440/7200 | 60 | 190 | 3 |
| 0/12/60/2520/15120 | 60 | 140 | 2,5 |
| 0/12/60/2520/15120 | 60 | 140 | 2,5 |
| 0/12/60/2520/15120 | 60 | 115 | 1,8 |
| 1/0/4 | 4 | | 3,5 |



Versailles Satin Copper

INOX 18/10 / 3,5mm / Satin



INOX
STAINLESS
STEEL
304

**BAJO PEDIDO
ON DEMAND**

- A **5754** CUCHILLO MESA
table knife, couteau table, coltello tavola, tafelmesser
- B **5755** CUCHARA MESA
table spoon, cuillère table, cucchiaio tavola, tafellöffel
- C **5756** TENEDOR MESA
table fork, fourchette table, forchetta tavola, tafelgabel
- D **5757** CUCHILLO POSTRE
dessert knife, couteau dessert, coltello frutta, dessertmesser
- E **5758** CUCHARA POSTRE
dessert spoon, cuillère dessert, cucchiaio frutta, dessertlöffel
- F **5759** TENEDOR POSTRE
dessert fork, fourchette dessert, forchetta frutta, dessertgabel
- G **5760** TENEDOR LUNCH
cake fork, fourchette gâteau, forchetta dolce, kuchengabel
- H **5761** CUCHARA CAFÉ
tea spoon, cuillère café, cucchiaio caffè, kaffeelöffel
- I **5762** CUCHARA MOKA
coffee/moka spoon, cuillère moka, cucchiaio moka, mokkalöffel

8806 24 PIEZAS
24 pieces, écriin 24 pièces, bauletto 24 pz., 24 stück

| UE | MOQ | ▶ mm | ✂ mm |
|--------------------|-----|------|------|
| 0/12/60/1920/5760 | 60 | 245 | |
| 0/12/60/1440/7200 | 60 | 210 | 3,5 |
| 0/12/60/1440/7200 | 60 | 210 | 3,5 |
| 0/12/60/1920/5760 | 60 | 220 | |
| 0/12/60/1440/7200 | 60 | 190 | 3 |
| 0/12/60/1440/7200 | 60 | 190 | 3 |
| 0/12/60/2520/15120 | 60 | 140 | 2,5 |
| 0/12/60/2520/15120 | 60 | 140 | 2,5 |
| 0/12/60/2520/15120 | 60 | 115 | 1,8 |
| 1/0/4 | 4 | | 3,5 |



Versailles Satin Gold

INOX 18/10 / 3,5mm / Satin



Versailles Satin Black

INOX 18/10 / 3,5mm / Satin



INOX
STAINLESS
STEEL
304

**BAJO PEDIDO
ON DEMAND**

| | | |
|---|-------------|--|
| A | 5736 | CUCHILLO MESA table knife, couteau table, coltello tavola, tafelmesser |
| B | 5737 | CUCHARA MESA table spoon, cuillère table, cucchiaio tavola, tafellöffel |
| C | 5738 | TENEDOR MESA table fork, fourchette table, forchetta tavola, tafelgabel |
| D | 5739 | CUCHILLO POSTRE dessert knife, couteau dessert, coltello frutta, dessertmesser |
| E | 5740 | CUCHARA POSTRE dessert spoon, cuillère dessert, cucchiaio frutta, dessertlöffel |
| F | 5741 | TENEDOR POSTRE dessert fork, fourchette dessert, forchetta frutta, dessertgabel |
| G | 5742 | TENEDOR LUNCH cake fork, fourchette gâteau, forchetta dolce, kuchengabel |
| H | 5743 | CUCHARA CAFÉ tea spoon, cuillère café, cucchiaio caffè, kaffeelöffel |
| I | 5744 | CUCHARA MOKA coffee/moka spoon, cuillère moka, cucchiaio moka, mokkalöffel |

8800 24 PIEZAS
24 pieces, écriin 24 pièces, bauletto 24 pz., 24 stück

UE MOQ ▶ mm ✂ mm

| | | | |
|--------------------|----|-----|-----|
| 0/12/60/1920/5760 | 60 | 245 | |
| 0/12/60/1440/7200 | 60 | 210 | 3,5 |
| 0/12/60/1440/7200 | 60 | 210 | 3,5 |
| 0/12/60/1920/5760 | 60 | 220 | |
| 0/12/60/1440/7200 | 60 | 190 | 3 |
| 0/12/60/1440/7200 | 60 | 190 | 3 |
| 0/12/60/2520/15120 | 60 | 140 | 2,5 |
| 0/12/60/2520/15120 | 60 | 140 | 2,5 |
| 0/12/60/2520/15120 | 60 | 115 | 1,8 |

1/0/4 4 3,5



INOX
STAINLESS
STEEL
304

**BAJO PEDIDO
ON DEMAND**

| | | |
|---|-------------|--|
| A | 5745 | CUCHILLO MESA table knife, couteau table, coltello tavola, tafelmesser |
| B | 5746 | CUCHARA MESA table spoon, cuillère table, cucchiaio tavola, tafellöffel |
| C | 5747 | TENEDOR MESA table fork, fourchette table, forchetta tavola, tafelgabel |
| D | 5748 | CUCHILLO POSTRE dessert knife, couteau dessert, coltello frutta, dessertmesser |
| E | 5749 | CUCHARA POSTRE dessert spoon, cuillère dessert, cucchiaio frutta, dessertlöffel |
| F | 5750 | TENEDOR POSTRE dessert fork, fourchette dessert, forchetta frutta, dessertgabel |
| G | 5751 | TENEDOR LUNCH cake fork, fourchette gâteau, forchetta dolce, kuchengabel |
| H | 5752 | CUCHARA CAFÉ tea spoon, cuillère café, cucchiaio caffè, kaffeelöffel |
| I | 5753 | CUCHARA MOKA coffee/moka spoon, cuillère moka, cucchiaio moka, mokkalöffel |

8803 24 PIEZAS
24 pieces, écriin 24 pièces, bauletto 24 pz., 24 stück

UE MOQ ▶ mm ✂ mm

| | | | |
|--------------------|----|-----|-----|
| 0/12/60/1920/5760 | 60 | 245 | |
| 0/12/60/1440/7200 | 60 | 210 | 3,5 |
| 0/12/60/1440/7200 | 60 | 210 | 3,5 |
| 0/12/60/1920/5760 | 60 | 220 | |
| 0/12/60/1440/7200 | 60 | 190 | 3 |
| 0/12/60/1440/7200 | 60 | 190 | 3 |
| 0/12/60/2520/15120 | 60 | 140 | 2,5 |
| 0/12/60/2520/15120 | 60 | 140 | 2,5 |
| 0/12/60/2520/15120 | 60 | 115 | 1,8 |

1/0/4 4 3,5





INOX 18/10 / 4mm / Mirror



- A **7288** CUCHILLO MESA CLASICO
classic table knife, couteau table classic, coltello tavola classic, tafelmesser classic
- B **6485** CUCHILLO MESA
table knife, couteau table, coltello tavola, tafelmesser
- C **6486** CUCHARA MESA
table spoon, cuillère table, cucchiaio tavola, tafellöffel
- D **6487** TENEDOR MESA
table fork, fourchette table, forchetta tavola, tafelgabel
- E **6488** PALA PESCADO
fish knife, couteau poisson, coltello pesce, fischmesser
- F **6489** TENEDOR PESCADO
fish fork, fourchette poisson, forchetta pesce, fischgabel
- G **6691** CUCHILLO POSTRE CLASICO
classic dessert knife, couteau dessert classic, coltello frutta classic, dessertmesser classic
- H **6490** CUCHILLO POSTRE
dessert knife, couteau dessert, coltello frutta, dessertmesser
- I **6491** CUCHARA POSTRE
dessert spoon, cuillère dessert, cucchiaio frutta, dessertlöffel
- J **6492** TENEDOR POSTRE
dessert fork, fourchette dessert, forchetta frutta, dessertgabel
- K **6493** TENEDOR LUNCH
cake fork, fourchette gâteau, forchetta dolce, kuchengabel
- L **6494** CUCHARA CAFÉ
tea spoon, cuillère café, cucchiaio caffè, kaffeelöffel
- M **6495** CUCHARA MOKA
coffee/moka spoon, cuillère moka, cucchiaio moka, mokkalöffel

- 6496** 24 PIEZAS
24 pieces, écriin 24 pièces, bauletto 24 pz., 24 stück

| UE | MOQ | mm | mm |
|---------------------|-----|-----|-----|
| 0/12/120/1920/5760 | 60 | 238 | |
| 0/12/120/1920/5760 | 60 | 238 | |
| 0/12/120/1440/7200 | 60 | 212 | 4 |
| 0/12/120/1440/7200 | 60 | 212 | 4 |
| 0/12/120/1440/7200 | 60 | 215 | 4 |
| 0/12/120/1440/7200 | 60 | 200 | 4 |
| 0/12/120/1920/5760 | 60 | 214 | |
| 0/12/120/1920/5760 | 60 | 214 | |
| 0/12/120/1440/7200 | 60 | 191 | 3,5 |
| 0/12/120/1440/7200 | 60 | 191 | 3,5 |
| 0/12/120/2520/15120 | 60 | 140 | 3,5 |
| 0/12/120/2520/15120 | 60 | 140 | 3,5 |
| 0/12/120/2520/15120 | 60 | 114 | 3,5 |



Maranta Vintage



INOX 18/10 / 4mm / Vintage

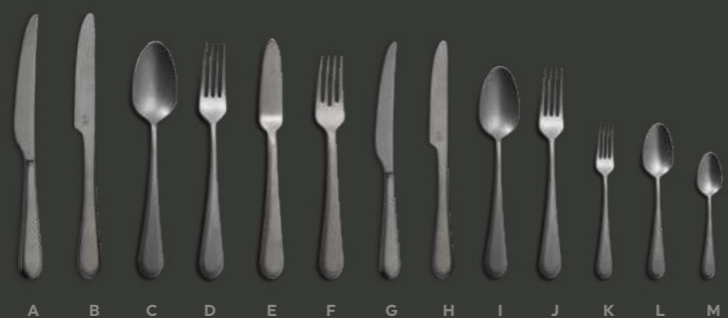

Maranta Vintage

INOX 18/10 / 4mm / Vintage

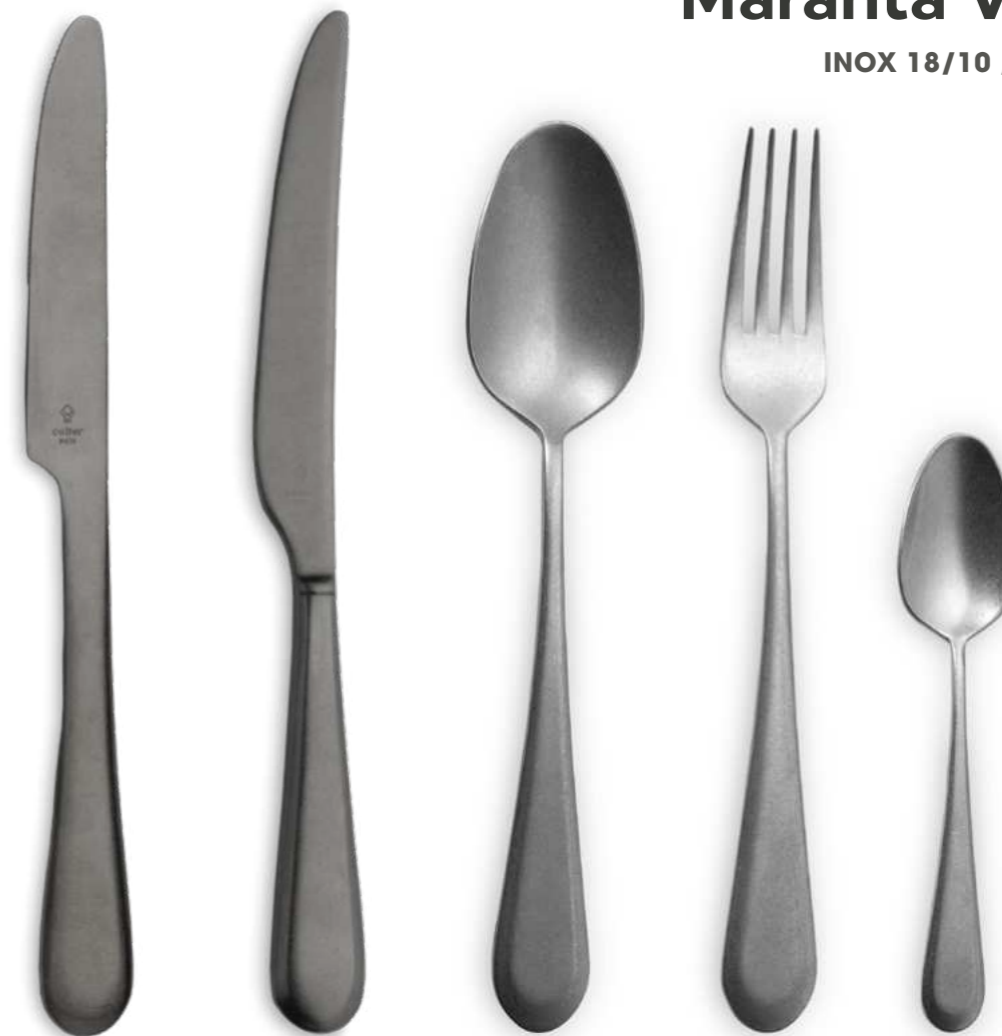

INOX
STAINLESS
STEEL
304

- A **7784** CUCHILLO MESA CLASICO
classic table knife, couteau table classic, coltello tavola classic, tafelmesser classic
- B **6793** CUCHILLO MESA
table knife, couteau table, coltello tavola, tafelmesser
- C **6794** CUCHARA MESA
table spoon, cuillère table, cucchiaio tavola, tafellöffel
- D **6795** TENEDOR MESA
table fork, fourchette table, forchetta tavola, tafelgabel
- E **6796** PALA PESCADO
fish knife, couteau poisson, coltello pesce, fischmesser
- F **6797** TENEDOR PESCADO
fish fork, fourchette poisson, forchetta pesce, fischgabel
- G **6692** CUCHILLO POSTRE CLASICO
classic dessert knife, couteau dessert classic, coltello frutta classic, dessertmesser classic
- H **6798** CUCHILLO POSTRE
dessert knife, couteau dessert, coltello frutta, dessertmesser
- I **6799** CUCHARA POSTRE
dessert spoon, cuillère dessert, cucchiaio frutta, dessertlöffel
- J **6800** TENEDOR POSTRE
dessert fork, fourchette dessert, forchetta frutta, dessertgabel
- K **6801** TENEDOR LUNCH
cake fork, fourchette gâteau, forchetta dolce, kuchengabel
- L **6802** CUCHARA CAFÉ
tea spoon, cuillère café, cucchiaio caffè, kaffeelöffel
- M **6803** CUCHARA MOKA
coffee/moka spoon, cuillère moka, cucchiaio moka, mokkalöffel

6804 24 PIEZAS
24 pieces, écriin 24 pièces, bauletto 24 pz., 24 stück

UE MOQ ▶ mm ✕ mm

| | | | |
|---------------------|----|-----|-----|
| 0/12/120/1920/5760 | 60 | 238 | |
| 0/12/120/1920/5760 | 60 | 238 | |
| 0/12/120/1440/7200 | 60 | 212 | 4 |
| 0/12/120/1440/7200 | 60 | 212 | 4 |
| 0/12/120/1440/7200 | 60 | 215 | 4 |
| 0/12/120/1440/7200 | 60 | 200 | 4 |
| 0/12/120/1920/5760 | 60 | 214 | |
| 0/12/120/1920/5760 | 60 | 214 | |
| 0/12/120/1440/7200 | 60 | 191 | 3,5 |
| 0/12/120/1440/7200 | 60 | 191 | 3,5 |
| 0/12/120/2520/15120 | 60 | 140 | 3,5 |
| 0/12/120/2520/15120 | 60 | 140 | 3,5 |
| 0/12/120/2520/15120 | 60 | 114 | 3,5 |

1/0/4 4 4





INOX 18/10 / 4mm / Mirror



INOX
STAINLESS
STEEL
304

- A **6700** CUCHILLO CHULETERO
steak knife, couteau steak, coltello bistecca, steakmesser
- B **6701** CUCHILLO MESA
table knife, couteau table, coltello tavola, tafelmesser
- C **6702** CUCHARA MESA
table spoon, cuillère table, cucchiaio tavola, tafellöffel
- D **6703** TENEDOR MESA
table fork, fourchette table, forchetta tavola, tafelgabel
- E **6497** PALA PESCADO
fish knife, couteau poisson, coltello pesce, fischmesser
- F **6498** TENEDOR PESCADO
fish fork, fourchette poisson, forchetta pesce, fischgabel
- G **6704** CUCHILLO POSTRE
dessert knife, couteau dessert, coltello frutta, dessertmesser
- H **6705** CUCHARA POSTRE
dessert spoon, cuillère dessert, cucchiaio frutta, dessertlöffel
- I **6706** TENEDOR POSTRE
dessert fork, fourchette dessert, forchetta frutta, dessertgabel
- J **6707** TENEDOR LUNCH
cake fork, fourchette gâteau, forchetta dolce, kuchengabel
- K **6708** CUCHARA CAFÉ
tea spoon, cuillère café, cucchiaio caffè, kaffeelöffel
- L **6709** CUCHARA MOKA
coffee/moka spoon, cuillère moka, cucchiaio moka, mokkalöffel

- 6710** 24 PIEZAS
24 pieces, écriin 24 pièces, bauletto 24 pz, 24 stück

| UE | MOQ | ▶ mm | ✕ mm |
|---------------------|-----|------|------|
| 0/12/120/1920/5760 | 60 | 233 | |
| 0/12/120/1920/5760 | 60 | 228 | |
| 0/12/120/1440/7200 | 60 | 208 | 4 |
| 0/12/120/1440/7200 | 60 | 208 | 4 |
| 0/12/120/1440/7200 | 60 | 212 | 4 |
| 0/12/120/1440/7200 | 60 | 205 | 4 |
| 0/12/120/1920/5760 | 60 | 208 | |
| 0/12/120/1440/7200 | 60 | 186 | 3,5 |
| 0/12/120/1440/7200 | 60 | 186 | 3,5 |
| 0/12/120/2520/15120 | 60 | 152 | 2,5 |
| 0/12/120/2520/15120 | 60 | 150 | 2,5 |
| 0/12/120/2520/15120 | 60 | 115 | 2 |
| 1/0/4 | 4 | | 4 |



London Vintage



INOX 18/10 / 4mm / Vintage



A B C D E F G H I J K L

London Vintage

INOX 18/10 / 4mm / Vintage



INOX
STAINLESS
STEEL
304

| | | UE | MOQ | ▶ mm | ✂ mm |
|-------------|--|---------------------|-----|------|------|
| A | 6805 CUCHILLO CHULETERO steak knife, couteau steak, coltello bistecca, steakmesser | 0/12/120/1920/5760 | 60 | 233 | |
| B | 6806 CUCHILLO MESA table knife, couteau table, coltello tavola, tafelmesser | 0/12/120/1920/5760 | 60 | 228 | |
| C | 6807 CUCHARA MESA table spoon, cuillère table, cucchiaio tavola, tafellöffel | 0/12/120/1440/7200 | 60 | 208 | 4 |
| D | 6808 TENEDOR MESA table fork, fourchette table, forchetta tavola, tafelgabel | 0/12/120/1440/7200 | 60 | 208 | 4 |
| E | 6809 PALA PESCADO fish knife, couteau poisson, coltello pesce, fischmesser | 0/12/120/1440/7200 | 60 | 212 | 4 |
| F | 6810 TENEDOR PESCADO fish fork, fourchette poisson, forchetta pesce, fischgabel | 0/12/120/1440/7200 | 60 | 205 | 4 |
| G | 6811 CUCHILLO POSTRE dessert knife, couteau dessert, coltello frutta, dessertmesser | 0/12/120/1920/5760 | 60 | 208 | |
| H | 6812 CUCHARA POSTRE dessert spoon, cuillère dessert, cucchiaio frutta, dessertlöffel | 0/12/120/1440/7200 | 60 | 186 | 3,5 |
| I | 6813 TENEDOR POSTRE dessert fork, fourchette dessert, forchetta frutta, dessertgabel | 0/12/120/1440/7200 | 60 | 186 | 3,5 |
| J | 6814 TENEDOR LUNCH cake fork, fourchette gâteau, forchetta dolce, kuchengabel | 0/12/120/2520/15120 | 60 | 152 | 2,5 |
| K | 6815 CUCHARA CAFÉ tea spoon, cuillère café, cucchiaio caffè, kaffeelöffel | 0/12/120/2520/15120 | 60 | 150 | 2,5 |
| L | 6816 CUCHARA MOKA coffee/moka spoon, cuillère moka, cucchiaio moka, mokkalöffel | 0/12/120/2520/15120 | 60 | 115 | 2 |
| 6817 | 24 PIEZAS 24 pieces, écriin 24 pièces, bauletto 24 pz., 24 stück | 1/0/4 | 4 | | 4 |



Violet

INOX 18/10 / 4mm / Mirror



Tulip

INOX 18/10/ 4mm / Mirror

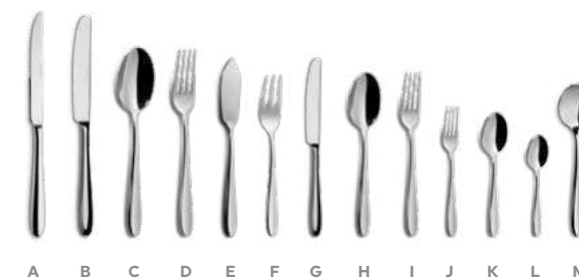

INOX STAINLESS STEEL 304

| | | | | | | |
|---|-------------|--|---------------------|----|-----|-----|
| A | 7046 | CUCHILLO MESA table knife, couteau table, coltello tavola, tafelmesser | 0/12/120/1920/5760 | 60 | 240 | |
| B | 7047 | CUCHARA MESA table spoon, cuillère table, cucchiaio tavola, tafellöffel | 0/12/120/1440/7200 | 60 | 214 | 4 |
| C | 7048 | TENEDOR MESA table fork, fourchette table, forchetta tavola, tafelgabel | 0/12/120/1440/7200 | 60 | 213 | 4 |
| D | 7049 | PALA PESCADO fish knife, couteau poisson, coltello pesce, fischmesser | 0/12/120/1440/7200 | 60 | 187 | 3,5 |
| E | 7050 | TENEDOR PESCADO fish fork, fourchette poisson, forchetta pesce, fischgabel | 0/12/120/1440/7200 | 60 | 174 | 3,5 |
| F | 7051 | CUCHILLO POSTRE dessert knife, couteau dessert, coltello frutta, dessertmesser | 0/12/120/1920/5760 | 60 | 209 | |
| G | 7052 | CUCHARA POSTRE dessert spoon, cuillère dessert, cucchiaio frutta, dessertlöffel | 0/12/120/1440/7200 | 60 | 176 | 3,5 |
| H | 7053 | TENEDOR POSTRE dessert fork, fourchette dessert, forchetta frutta, dessertgabel | 0/12/120/1440/7200 | 60 | 175 | 3,5 |
| I | 7054 | TENEDOR LUNCH cake fork, fourchette gâteau, forchetta dolce, kuchengabel | 0/12/120/2520/15120 | 60 | 147 | 3 |
| J | 7055 | CUCHARA CAFÉ tea spoon, cuillère café, cucchiaio caffè, kaffeelöffel | 0/12/120/2520/15120 | 60 | 147 | 3 |
| K | 7056 | CUCHARA MOKA coffee/moka spoon, cuillère moka, cucchiaio moka, mokkalöffel | 0/12/120/2520/15120 | 60 | 121 | 2,5 |

5962 24 PIEZAS
24 pieces, écrin 24 pièces, bauletto 24 pz., 24 stück

INOX STAINLESS STEEL 304

| | | | | | | |
|---|-------------|---|---------------------|----|-----|-----|
| A | 7033 | CUCHILLO CHULETERO steak knife, couteau steak, coltello bistecca, steakmesser | 0/12/120/1920/5760 | 60 | 244 | |
| B | 7034 | CUCHILLO MESA table knife, couteau table, coltello tavola, tafelmesser | 0/12/120/1920/5760 | 60 | 237 | |
| C | 7035 | CUCHARA MESA table spoon, cuillère table, cucchiaio tavola, tafellöffel | 0/12/120/1440/7200 | 60 | 207 | 4 |
| D | 7036 | TENEDOR MESA table fork, fourchette table, forchetta tavola, tafelgabel | 0/12/120/1440/7200 | 60 | 206 | 4 |
| E | 7037 | PALA PESCADO fish knife, couteau poisson, coltello pesce, fischmesser | 0/12/120/1440/7200 | 60 | 195 | 3,5 |
| F | 7038 | TENEDOR PESCADO fish fork, fourchette poisson, forchetta pesce, fischgabel | 0/12/120/1440/7200 | 60 | 176 | 3,5 |
| G | 7039 | CUCHILLO POSTRE dessert knife, couteau dessert, coltello frutta, dessertmesser | 0/12/120/1920/5760 | 60 | 195 | |
| H | 7040 | CUCHARA POSTRE dessert spoon, cuillère dessert, cucchiaio frutta, dessertlöffel | 0/12/120/1440/7200 | 60 | 178 | 3,5 |
| I | 7041 | TENEDOR POSTRE dessert fork, fourchette dessert, forchetta frutta, dessertgabel | 0/12/120/1440/7200 | 60 | 179 | 3,5 |
| J | 7042 | TENEDOR LUNCH cake fork, fourchette gâteau, forchetta dolce, kuchengabel | 0/12/120/2520/15120 | 60 | 142 | 3 |
| K | 7043 | CUCHARA CAFÉ tea spoon, cuillère café, cucchiaio caffè, kaffeelöffel | 0/12/120/2520/15120 | 60 | 135 | 3 |
| L | 7044 | CUCHARA MOKA coffee/moka spoon, cuillère moka, cucchiaio moka, mokkalöffel | 0/12/120/2520/15120 | 60 | 111 | 2,5 |
| M | 7045 | CUCHARA CONSOMÉ consommé spoon, cuillère consommé, cucchiaio zuppa, bouillonlöffel | 0/12/120/1440/7200 | 60 | 166 | 3,5 |

5961 24 PIEZAS
24 pieces, écrin 24 pièces, bauletto 24 pz., 24 stück

| UE | MOQ | ▶ mm | ✂ mm |
|---------------------|-----|------|------|
| 0/12/120/1920/5760 | 60 | 244 | |
| 0/12/120/1920/5760 | 60 | 237 | |
| 0/12/120/1440/7200 | 60 | 207 | 4 |
| 0/12/120/1440/7200 | 60 | 206 | 4 |
| 0/12/120/1440/7200 | 60 | 195 | 3,5 |
| 0/12/120/1440/7200 | 60 | 176 | 3,5 |
| 0/12/120/1920/5760 | 60 | 195 | |
| 0/12/120/1440/7200 | 60 | 178 | 3,5 |
| 0/12/120/1440/7200 | 60 | 179 | 3,5 |
| 0/12/120/2520/15120 | 60 | 142 | 3 |
| 0/12/120/2520/15120 | 60 | 135 | 3 |
| 0/12/120/2520/15120 | 60 | 111 | 2,5 |
| 0/12/120/1440/7200 | 60 | 166 | 3,5 |
| 1/0/4 | 4 | | 4 |

Chef

INOX 18/10 /4mm / Mirror



Lotus

INOX 18/10 / 4mm / Mirror



| | | | | | | |
|--------------|--------------|---|---------------------|----|-----|-----|
| A | 3107 | CUCHILLO CHULETERO SUTIL steak knife sutil, couteau steak sutil, coltello bistecca sutil, steakmesser sutil | 0/6/60/720/3600 | 60 | 232 | |
| B | 5033 | CUCHILLO MESA table knife, couteau table, coltello tavola, tafelmesser | 0/12/120/1920/5760 | 60 | 235 | |
| NEW C | 11915 | CUCHARA MESA table spoon, cuillère table, cucchiaio tavola, tafellöffel | 0/12/120/1440/7200 | 60 | 200 | 4 |
| NEW D | 11916 | TENEDOR MESA table fork, fourchette table, forchetta tavola, tafelgabel | 0/12/120/1440/7200 | 60 | 200 | 4 |
| E | 3702 | PALA PESCADO fish knife, couteau poisson, coltello pesce, fischmesser | 0/12/120/1440/7200 | 60 | 205 | 3 |
| F | 3703 | TENEDOR PESCADO fish fork, fourchette poisson, forchetta pesce, fischgabel | 0/12/120/1440/7200 | 60 | 195 | 3 |
| G | 5034 | CUCHILLO POSTRE dessert knife, couteau dessert, coltello frutta, dessertmesser | 0/12/120/1920/5760 | 60 | 210 | 2,5 |
| H | 3704 | CUCHARA POSTRE dessert spoon, cuillère dessert, cucchiaio frutta, dessertlöffel | 0/12/120/1440/7200 | 60 | 180 | 2,5 |
| I | 3705 | TENEDOR POSTRE dessert fork, fourchette dessert, forchetta frutta, dessertgabel | 0/12/120/1440/7200 | 60 | 180 | 2,5 |
| J | 3706 | TENEDOR LUNCH cake fork, fourchette gâteau, forchetta dolce, kuchengabel | 0/12/120/2520/15120 | 60 | 148 | 2 |
| K | 3707 | CUCHARA CAFÉ tea spoon, cuillère café, cucchiaio caffè, kaffeelöffel | 0/12/120/2520/15120 | 60 | 140 | 2 |
| L | 3708 | CUCHARA MOKA coffee/moka spoon, cuillère moka, cucchiaio moka, mokkalöffel | 0/12/120/2520/15120 | 60 | 116 | 2 |

0706 24 PIEZAS
24 pieces, écrin 24 pièces, bauletto 24 pz., 24 stück



| | | | | | | |
|---|-------------|---|---------------------|----|-----|-----|
| A | 6696 | CUCHILLO CHULETERO steak knife, couteau steak, coltello bistecca, steakmesser | 0/12/120/1920/5760 | 60 | 235 | |
| B | 3139 | CUCHILLO MESA table knife, couteau table, coltello tavola, tafelmesser | 0/12/120/1920/5760 | 60 | 225 | |
| C | 3141 | CUCHARA MESA table spoon, cuillère table, cucchiaio tavola, tafellöffel | 0/12/120/1440/7200 | 60 | 211 | 4 |
| D | 3142 | TENEDOR MESA table fork, fourchette table, forchetta tavola, tafelgabel | 0/12/120/1440/7200 | 60 | 211 | 4 |
| E | 3143 | PALA PESCADO fish knife, couteau poisson, coltello pesce, fischmesser | 0/12/120/1440/7200 | 60 | 206 | 3,5 |
| F | 3144 | TENEDOR PESCADO fish fork, fourchette poisson, forchetta pesce, fischgabel | 0/12/120/1440/7200 | 60 | 186 | 3,5 |
| G | 3145 | CUCHILLO POSTRE dessert knife, couteau dessert, coltello frutta, dessertmesser | 0/12/120/1920/5760 | 60 | 195 | |
| H | 3146 | CUCHARA POSTRE dessert spoon, cuillère dessert, cucchiaio frutta, dessertlöffel | 0/12/120/1440/7200 | 60 | 188 | 3,5 |
| I | 3147 | TENEDOR POSTRE dessert fork, fourchette dessert, forchetta frutta, dessertgabel | 0/12/120/1440/7200 | 60 | 186 | 3,5 |
| J | 3148 | TENEDOR LUNCH cake fork, fourchette gâteau, forchetta dolce, kuchengabel | 0/12/120/2520/15120 | 60 | 147 | 3 |
| K | 3149 | CUCHARA CAFÉ tea spoon, cuillère café, cucchiaio caffè, kaffeelöffel | 0/12/120/2520/15120 | 60 | 139 | 3 |
| L | 3150 | CUCHARA MOKA coffee/moka spoon, cuillère moka, cucchiaio moka, mokkalöffel | 0/12/120/2520/15120 | 60 | 114 | 2,5 |
| M | 3176 | PALA MANTEQUILLA butter knife, couteau beurre, coltello burro, buttermesser | 0/12/120/1440/7200 | 60 | 180 | 3 |

5960 24 PIEZAS
24 pieces, écrin 24 pièces, bauletto 24 pz., 24 stück

| UE | MOQ | ✂ mm | ✂ mm |
|---------------------|-----|------|------|
| 0/12/120/1920/5760 | 60 | 235 | |
| 0/12/120/1920/5760 | 60 | 225 | |
| 0/12/120/1440/7200 | 60 | 211 | 4 |
| 0/12/120/1440/7200 | 60 | 211 | 4 |
| 0/12/120/1440/7200 | 60 | 206 | 3,5 |
| 0/12/120/1440/7200 | 60 | 186 | 3,5 |
| 0/12/120/1920/5760 | 60 | 195 | |
| 0/12/120/1440/7200 | 60 | 188 | 3,5 |
| 0/12/120/1440/7200 | 60 | 186 | 3,5 |
| 0/12/120/2520/15120 | 60 | 147 | 3 |
| 0/12/120/2520/15120 | 60 | 139 | 3 |
| 0/12/120/2520/15120 | 60 | 114 | 2,5 |
| 0/12/120/1440/7200 | 60 | 180 | 3 |
| 1/0/4 | 4 | | 4 |





INOX 18/10 / 3,5mm / Mirror



A B C D E F G H I J K L M N O P

INOX 18/10 / 3,5mm / Mirror



Añadimos cuchara CLÁSICA a la colección, dando la posibilidad de adaptar la gama Munich a distintos estilos.

We add CLASSIC spoon to the collection, giving the possibility to adapt the Munich range to different styles.

INOX
STAINLESS
STEEL
304

| | UE | MOQ | ▶ mm | ✕ mm |
|--|---------------------|-----|------|------|
| A 6511 CUCHILLO CHULETERO steak knife, couteau steak, coltello bistecca, steakmesser | 0/12/120/1920/5760 | 60 | 237 | |
| B 6512 CUCHILLO MESA table knife, couteau table, coltello tavola, tafelmesser | 0/12/120/1920/5760 | 60 | 235 | |
| C 6513 CUCHARA MESA table spoon, cuillère table, cucchiaio tavola, tafellöffel | 0/12/120/1440/7200 | 60 | 210 | 3,5 |
| NEW D 11935 CUCHARA MESA CLASICA classic table spoon, cuillère table classic, cucchiaio tavola classic, tafellöffel classic | 0/12/120/1440/7200 | 60 | 210 | 3,5 |
| E 6514 TENEDOR MESA table fork, fourchette table, forchetta tavola, tafelgabel | 0/12/120/1440/7200 | 60 | 209 | 3,5 |
| F 6515 PALA PESCADO fish knife, couteau poisson, coltello pesce, fischmesser | 0/12/120/1440/7200 | 60 | 210 | 3 |
| G 6516 TENEDOR PESCADO fish fork, fourchette poisson, forchetta pesce, fischgabel | 0/12/120/1440/7200 | 60 | 207 | 3 |
| H 6517 CUCHILLO POSTRE dessert knife, couteau dessert, coltello frutta, dessertmesser | 0/12/120/1920/5760 | 60 | 209 | |
| I 6518 CUCHARA POSTRE dessert spoon, cuillère dessert, cucchiaio frutta, dessertlöffel | 0/12/120/1440/7200 | 60 | 182 | 3 |
| NEW J 11936 CUCHARA POSTRE CLASICA classic dessert spoon, cuillère dessert classic, cucchiaio frutta classic, dessertlöffel classic | 0/12/120/1440/7200 | 60 | 185 | 3 |
| K 6519 TENEDOR POSTRE dessert fork, fourchette dessert, forchetta frutta, dessertgabel | 0/12/120/1440/7200 | 60 | 186 | 3 |
| L 6520 TENEDOR LUNCH cake fork, fourchette gâteau, forchetta dolce, kuchengabel | 0/12/120/2520/15120 | 60 | 153 | 2,5 |
| M 6521 CUCHARA CAFÉ tea spoon, cuillère café, cucchiaio caffè, kaffeelöffel | 0/12/120/2520/15120 | 60 | 150 | 2,5 |
| NEW N 11937 CUCHARA CAFÉ CLASICA classic tea spoon, cuillère café classic, cucchiaio caffè classic, kaffeelöffel classic | 0/12/120/2520/15120 | 60 | 150 | 2,5 |
| O 6522 CUCHARA MOKA coffee/moka spoon, cuillère moka, cucchiaio moka, mokkalöffel | 0/12/120/2520/15120 | 60 | 115 | 2,5 |
| NEW P 11938 CUCHARA MOKA CLASICA classic coffee/moka spoon, cuillère moka classic, cucchiaio moka classic, mokkalöffel classic | 0/12/120/2520/15120 | 60 | 115 | 2,5 |
| 6523 24 PIEZAS 24 pieces, écrin 24 pièces, bauletto 24 pz., 24 stück | 1/0/4 | 4 | | 3,5 |



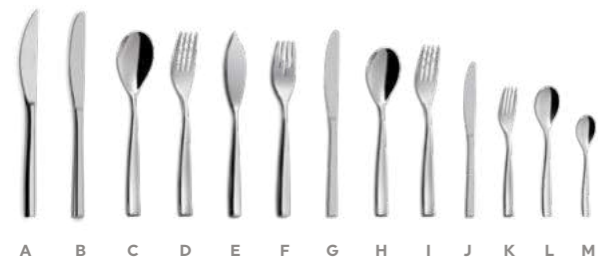

INOX
STAINLESS
STEEL
304

| | | | | | | |
|---|-------------|---|---------------------|----|-----|-----|
| A | 0764 | CUCHILLO CHULETERO steak knife, couteau steak, coltello bistecca, steakmesser | 0/12/120/1920/5760 | 60 | 223 | |
| B | 0268 | CUCHILLO MESA table knife, couteau table, coltello tavola, tafelmesser | 0/12/120/1920/5760 | 60 | 221 | |
| C | 2736 | CUCHARA MESA table spoon, cuillère table, cucchiaio tavola, tafellöffel | 0/12/120/1440/7200 | 60 | 200 | 3,5 |
| D | 2735 | TENEDOR MESA table fork, fourchette table, forchetta tavola, tafelgabel | 0/12/120/1440/7200 | 60 | 200 | 3,5 |
| E | 2742 | PALA PESCADO fish knife, couteau poisson, coltello pesce, fischmesser | 0/12/120/1440/7200 | 60 | 200 | 2,5 |
| F | 2741 | TENEDOR PESCADO fish fork, fourchette poisson, forchetta pesce, fischgabel | 0/12/120/1440/7200 | 60 | 190 | 2,5 |
| G | 5807 | CUCHILLO POSTRE dessert knife, couteau dessert, coltello frutta, dessertmesser | 0/12/120/1920/5760 | 60 | 202 | |
| H | 2740 | CUCHARA POSTRE dessert spoon, cuillère dessert, cucchiaio frutta, dessertlöffel | 0/12/120/1440/7200 | 60 | 183 | 2,5 |
| I | 2738 | TENEDOR POSTRE dessert fork, fourchette dessert, forchetta frutta, dessertgabel | 0/12/120/1440/7200 | 60 | 185 | 2,5 |
| J | 5814 | CUCHILLO LUNCH cake knife, couteau gâteau, coltello dolce, kuchenmesser | 0/12/120/1920/5760 | 60 | 167 | |
| K | 2745 | TENEDOR LUNCH cake fork, fourchette gâteau, forchetta dolce, kuchengabel | 0/12/120/2520/15120 | 60 | 140 | 2,5 |
| L | 2743 | CUCHARA CAFÉ tea spoon, cuillère café, cucchiaio caffè, kaffeelöffel | 0/12/120/2520/15120 | 60 | 140 | 2,5 |
| M | 2744 | CUCHARA MOKA coffee/moka spoon, cuillère moka, cucchiaio moka, mokkalöffel | 0/12/120/2520/15120 | 60 | 110 | 2,5 |

2797 **24 PIEZAS**
24 pieces, écriin 24 pièces, bauletto 24 pz., 24 stück

| UE | MOQ | ▶ mm | ✂ mm |
|---------------------|-----|------|------|
| 0/12/120/1920/5760 | 60 | 223 | |
| 0/12/120/1920/5760 | 60 | 221 | |
| 0/12/120/1440/7200 | 60 | 200 | 3,5 |
| 0/12/120/1440/7200 | 60 | 200 | 3,5 |
| 0/12/120/1440/7200 | 60 | 200 | 2,5 |
| 0/12/120/1440/7200 | 60 | 190 | 2,5 |
| 0/12/120/1920/5760 | 60 | 202 | |
| 0/12/120/1440/7200 | 60 | 183 | 2,5 |
| 0/12/120/1440/7200 | 60 | 185 | 2,5 |
| 0/12/120/1920/5760 | 60 | 167 | |
| 0/12/120/2520/15120 | 60 | 140 | 2,5 |
| 0/12/120/2520/15120 | 60 | 140 | 2,5 |
| 0/12/120/2520/15120 | 60 | 110 | 2,5 |
| 1/0/4 | 4 | | 3,5 |



INOX
STAINLESS
STEEL
304

| | | | | | | |
|---|-------------|--|---------------------|----|-----|-----|
| A | 5821 | CUCHILLO MESA table knife, couteau table, coltello tavola, tafelmesser | 0/12/120/1920/5760 | 60 | 229 | |
| B | 5822 | CUCHARA MESA table spoon, cuillère table, cucchiaio tavola, tafellöffel | 0/12/120/1440/7200 | 60 | 205 | 3,5 |
| C | 5823 | TENEDOR MESA table fork, fourchette table, forchetta tavola, tafelgabel | 0/12/120/1440/7200 | 60 | 205 | 3,5 |
| D | 5824 | PALA PESCADO fish knife, couteau poisson, coltello pesce, fischmesser | 0/12/120/1440/7200 | 60 | 215 | 3,5 |
| E | 5825 | TENEDOR PESCADO fish fork, fourchette poisson, forchetta pesce, fischgabel | 0/12/120/1440/7200 | 60 | 195 | 3,5 |
| F | 5826 | CUCHILLO POSTRE dessert knife, couteau dessert, coltello frutta, dessertmesser | 0/12/120/1920/5760 | 60 | 200 | |
| G | 5827 | CUCHARA POSTRE dessert spoon, cuillère dessert, cucchiaio frutta, dessertlöffel | 0/12/120/1440/7200 | 60 | 190 | 3,5 |
| H | 5828 | TENEDOR POSTRE dessert fork, fourchette dessert, forchetta frutta, dessertgabel | 0/12/120/1440/7200 | 60 | 185 | 3,5 |
| I | 5829 | TENEDOR LUNCH cake fork, fourchette gâteau, forchetta dolce, kuchengabel | 0/12/120/2520/15120 | 60 | 140 | 2,5 |
| J | 5830 | CUCHARA CAFÉ tea spoon, cuillère café, cucchiaio caffè, kaffeelöffel | 0/12/120/2520/15120 | 60 | 147 | 2,5 |
| K | 5831 | CUCHARA MOKA coffee/moka spoon, cuillère moka, cucchiaio moka, mokkalöffel | 0/12/120/2520/15120 | 60 | 110 | 2 |
| L | 3158 | CUCHARA CONSOMÉ consommé spoon, cuillère consommé, cucchiaio zuppa, bouillonlöffel | 0/12/120/1440/7200 | 60 | 180 | 2,5 |
| M | 0463 | CAZO SOPA soup ladle, louche à potage, mestolo, suppenkelle | 1/10/50/150/750 | 10 | 280 | 3,5 |
| N | 0464 | CUCHARA ENSALADA salad spoon, cuillère à servir salade, cucchiaio servire, salatlöffel | 1/10/50/800/4000 | 10 | 275 | 3,5 |
| O | 0465 | TENEDOR ENSALADA salad fork, fourchette à servir salade, forchetta servire, salatgabel | 1/10/50/800/4000 | 10 | 275 | 3,5 |
| P | 0466 | PALA REPOSTERÍA cake server, pelle à tarte, pala torta, tortenheber | 1/10/50/600/2400 | 10 | 260 | 3,5 |
| Q | 0467 | CAZO SALSA sauce ladle, cuillère à sauce, mestolino salsa, soßenkelle | 1/10/50/800/4000 | 10 | 180 | 3,5 |

2900 **24 PIEZAS**
24 pieces, écriin 24 pièces, bauletto 24 pz., 24 stück

| UE | MOQ | ▶ mm | ✂ mm |
|---------------------|-----|------|------|
| 0/12/120/1920/5760 | 60 | 229 | |
| 0/12/120/1440/7200 | 60 | 205 | 3,5 |
| 0/12/120/1440/7200 | 60 | 205 | 3,5 |
| 0/12/120/1440/7200 | 60 | 215 | 3,5 |
| 0/12/120/1440/7200 | 60 | 195 | 3,5 |
| 0/12/120/1920/5760 | 60 | 200 | |
| 0/12/120/1440/7200 | 60 | 190 | 3,5 |
| 0/12/120/1440/7200 | 60 | 185 | 3,5 |
| 0/12/120/2520/15120 | 60 | 140 | 2,5 |
| 0/12/120/2520/15120 | 60 | 147 | 2,5 |
| 0/12/120/2520/15120 | 60 | 110 | 2 |
| 0/12/120/1440/7200 | 60 | 180 | 2,5 |
| 1/10/50/150/750 | 10 | 280 | 3,5 |
| 1/10/50/800/4000 | 10 | 275 | 3,5 |
| 1/10/50/800/4000 | 10 | 275 | 3,5 |
| 1/10/50/600/2400 | 10 | 260 | 3,5 |
| 1/10/50/800/4000 | 10 | 180 | 3,5 |
| 1/0/4 | 4 | | 3,5 |



North XL

INOX 18/10 / 3mm / Mirror



North XL

INOX 18/10 / 3mm / Mirror



INOX STAINLESS STEEL 304

- A **4402** CUCHILLO CHULETERO
steak knife, couteau steak, coltello bistecca, steakmesser
- B **5525** TENEDOR CHULETERO
steak fork, fourchette steak, forchetta bistecca, steakgabel
- NEW** C **11923** CUCHILLO MESA CLASICO
classic table knife, couteau table classic, coltello tavola classic, tafelmesser classic
- !** D **4535** CUCHILLO MESA
table knife, couteau table, coltello tavola, tafelmesser
- UP** E **4536** CUCHARA MESA
table spoon, cuillère table, cucchiaio tavola, tafellöffel
- UP** F **4537** TENEDOR MESA
table fork, fourchette table, forchetta tavola, tafelgabel
- G **5376** PALA PESCADO
fish knife, couteau poisson, coltello pesce, fischmesser
- H **5377** TENEDOR PESCADO
fish fork, fourchette poisson, forchetta pesce, fischgabel
- NEW** I **11924** CUCHILLO POSTRE CLASICO
classic dessert knife, couteau dessert classic, coltello frutta classic, dessertmesser classic
- !** J **4538** CUCHILLO POSTRE
dessert knife, couteau dessert, coltello frutta, dessertmesser
- K **5378** CUCHARA POSTRE
dessert spoon, cuillère dessert, cucchiaio frutta, dessertlöffel
- L **5379** TENEDOR POSTRE
dessert fork, fourchette dessert, forchetta frutta, dessertgabel
- NEW** M **11925** CUCHILLO LUNCH CLASICO
classic cake knife, couteau gâteau classic, coltello dolce classic, kuchenmesser classic
- !** N **5015** CUCHILLO LUNCH
cake knife, couteau gâteau, coltello dolce, kuchenmesser
- UP** O **3846** CUCHARA TÉ
iced tea spoon, cuillère à té, cucchiaio the, cocktaillöffel
- NEW** P **11926** TENEDOR LUNCH
cake fork, fourchette gâteau, forchetta dolce, kuchengabel
- UP** Q **3948** CUCHARA CAFÉ
tea spoon, cuillère café, cucchiaio caffè, kaffeeöffel
- UP** R **3949** CUCHARA MOKA
coffee/moka spoon, cuillère moka, cucchiaio moka, mokkalöffel
- S **4993** CUCHARA REFRESCO
soda spoon, cuillère mazagran, cucchiaio bibita, longdrinklöffel
- T **5533** TENEDOR ARROZ
rice fork, fourchette à riz, forchetta riso, reisgabel
- U **3154** CUCHARA CONSOMÉ
consommé spoon, cuillère consommé, cucchiaio zuppa, bouillonlöffel
- NEW** V **12030** PALA MANTEQUILLA
butter knife, cuillère consommé, cucchiaio zuppa, bouillonlöffel

| UE | MOQ | mm | mm |
|---------------------|-----|-----|-----|
| 0/12/120/1920/5760 | 60 | 228 | |
| 0/12/120/1440/7200 | 60 | 202 | 3 |
| 0/12/120/1440/7200 | 60 | 240 | |
| 0/12/120/1920/5760 | 60 | 240 | |
| 0/12/120/1440/7200 | 60 | 209 | 3 |
| 0/12/120/1440/7200 | 60 | 210 | 3 |
| 0/12/120/1440/7200 | 60 | 200 | 3 |
| 0/12/120/1440/7200 | 60 | 195 | 3 |
| 0/12/120/1920/5760 | 60 | 216 | |
| 0/12/120/1920/5760 | 60 | 212 | |
| 0/12/120/1440/7200 | 60 | 178 | 2,5 |
| 0/12/120/1440/7200 | 60 | 183 | 2,5 |
| 0/12/120/1920/5760 | 60 | 176 | |
| 0/12/120/1920/5760 | 60 | 178 | |
| 0/12/120/2520/15120 | 60 | 145 | 2 |
| 0/12/120/2520/15120 | 60 | 148 | 2 |
| 0/12/120/2520/15120 | 60 | 138 | 2 |
| 0/12/120/2520/15120 | 60 | 117 | 2 |
| 0/12/120/1440/7200 | 60 | 207 | 2 |
| 0/12/120/1440/7200 | 60 | 205 | 2,5 |
| 0/12/120/1440/7200 | 60 | 180 | 2,5 |
| 0/12/120/1440/7200 | 60 | 176 | 3 |



! BAJO PEDIDO
ON DEMAND

7119 24 PIEZAS
24 pieces, écrin 24 pièces, bauletto 24 pz., 24 stück

UE 1/0/4
MOQ 4
mm mm



North M

INOX 18/10 / 2,5mm / Mirror



A B C D



North S

INOX 18/10 / 2mm / Mirror



A B C D E F G H



INOX
STAINLESS
STEEL
304

- A **6359** CUCHILLO MESA GRANDE
long table knife, grande couteau table, coltello tavola grande, tafelmesser lang
- B **4007** CUCHARA MESA GRANDE
table spoon long, grande cuillère table, cucchiaio tavola grande, tafellöffel lang
- C **4008** TENEDOR MESA GRANDE
long table fork, grande fourchette table, forchetta tavola grande, tafelgabel lang
- D **3948** CUCHARA CAFÉ
tea spoon, cuillère café, cucchiaio caffè, kaffeelöffel

7120 24 PIEZAS
24 pieces, écrin 24 pièces, bauletto 24 pz., 24 stück

UE **MOQ** **▶ mm** **✕ mm**

| | | | |
|---------------------|----|-----|-----|
| 0/12/120/1920/5760 | 60 | 228 | |
| 0/12/120/1440/7200 | 60 | 198 | 2,5 |
| 0/12/120/1440/7200 | 60 | 198 | 2,5 |
| 0/12/120/2520/15120 | 60 | 135 | 2 |



INOX
STAINLESS
STEEL
304

- A **5631** CUCHILLO CHULETERO
steak knife, couteau steak, coltello bistecca, steakmesser
- B **0094** CUCHILLO MESA
table knife, couteau table, coltello tavola, tafelmesser
- C **3940** CUCHARA MESA
table spoon, cuillère table, cucchiaio tavola, tafellöffel
- D **3941** TENEDOR MESA
table fork, fourchette table, forchetta tavola, tafelgabel
- E **0099** CUCHILLO POSTRE
dessert knife, couteau dessert, coltello frutta, dessertmesser
- F **3947** TENEDOR LUNCH
cake fork, fourchette gâteau, forchetta dolce, kuchengabel
- G **5567** CUCHARA CAFÉ
tea spoon, cuillère café, cucchiaio caffè, kaffeelöffel
- H **5568** CUCHARA MOKA
coffee/moka spoon, cuillère moka, cucchiaio moka, mokkalöffel

7122 24 PIEZAS
24 pieces, écrin 24 pièces, bauletto 24 pz., 24 stück

UE **MOQ** **▶ mm** **✕ mm**

| | | | |
|---------------------|----|-----|-----|
| 0/12/120/1920/5760 | 60 | 230 | |
| 0/12/120/1920/5760 | 60 | 225 | |
| 0/12/120/1440/7200 | 60 | 193 | 1,8 |
| 0/12/120/1440/7200 | 60 | 190 | 2 |
| 0/12/120/1920/5760 | 60 | 195 | |
| 0/12/120/2520/15120 | 60 | 143 | 1,5 |
| 0/12/120/2520/15120 | 60 | 140 | 1,5 |
| 0/12/120/2520/15120 | 60 | 120 | 1,2 |



Baguette XL

INOX 18/10 / 3mm / Mirror



Baguette XL

INOX 18/10 / 3mm / Mirror



INOX STAINLESS STEEL 304

- A **3526** CUCHILLO CHULETERO
steak knife, couteau steak, coltello bistecca, steakmesser
- NEW** B **11923** CUCHILLO MESA CLASICO
classic table knife, couteau table classic, coltello tavola classic, tafelmesser classic
- C **5013** CUCHILLO MESA
table knife, couteau table, coltello tavola, tafelmesser
- UP** D **4365** CUCHARA MESA
table spoon, cuillère table, cucchiaio tavola, tafellöffel
- UP** E **4366** TENEDOR MESA
table fork, fourchette table, forchetta tavola, tafelgabel
- F **5297** PALA PESCADO
fish knife, couteau poisson, coltello pesce, fischmesser
- G **5298** TENEDOR PESCADO
fish fork, fourchette poisson, forchetta pesce, fischgabel
- NEW** H **11924** CUCHILLO POSTRE CLASICO
classic dessert knife, couteau dessert classic, coltello frutta classic, dessertmesser classic
- I **4367** CUCHILLO POSTRE
dessert knife, couteau dessert, coltello frutta, dessertmesser
- J **5299** CUCHARA POSTRE
dessert spoon, cuillère dessert, cucchiaio frutta, dessertlöffel
- K **5300** TENEDOR POSTRE
dessert fork, fourchette dessert, forchetta frutta, dessertgabel
- NEW** L **11925** CUCHILLO LUNCH CLASICO
classic cake knife, couteau gâteau classic, coltello dolce classic, kuchenmesser classic
- M **5014** CUCHILLO LUNCH
cake knife, couteau gâteau, coltello dolce, kuchenmesser
- UP** N **3877** CUCHARA TÉ
tea spoon, cuillère à té, cucchiaio the, cocktaillöffel
- NEW** O **11927** TENEDOR LUNCH
cake fork, fourchette gâteau, forchetta dolce, kuchengabel
- UP** P **5302** CUCHARA CAFÉ
tea spoon, cuillère café, cucchiaio caffè, kaffeelöffel
- UP** Q **5303** CUCHARA MOKA
coffee/moka spoon, cuillère moka, cucchiaio moka, mokkalöffel
- R **3155** CUCHARA CONSOMÉ
consommé spoon, cuillère consommé, cucchiaio zuppa, bouillonlöffel

| UE | MOQ | ▶ mm | ✂ mm |
|---------------------|-----|------|------|
| 0/12/120/1920/5760 | 60 | 230 | |
| 0/12/120/1920/5760 | 60 | 240 | |
| 0/12/120/1920/5760 | 60 | 240 | |
| 0/12/120/1440/7200 | 60 | 209 | 3 |
| 0/12/120/1440/7200 | 60 | 210 | 3 |
| 0/12/120/1440/7200 | 60 | 200 | 2,5 |
| 0/12/120/1440/7200 | 60 | 195 | 2,5 |
| 0/12/120/1920/5760 | 60 | 216 | |
| 0/12/120/1920/5760 | 60 | 178 | |
| 0/12/120/1440/7200 | 60 | 185 | 2,5 |
| 0/12/120/1440/7200 | 60 | 183 | 2,5 |
| 0/12/120/1920/5760 | 60 | 176 | |
| 0/12/120/1920/5760 | 60 | 138 | |
| 0/12/120/2520/15120 | 60 | 145 | 2 |
| 0/12/120/2520/15120 | 60 | 148 | 2 |
| 0/12/120/2520/15120 | 60 | 138 | 2 |
| 0/12/120/2520/15120 | 60 | 117 | 2 |
| 0/12/120/1440/7200 | 60 | 180 | 2,5 |



4883 24 PIEZAS
24 pieces, écrin 24 pièces, bauletto 24 pz., 24 stück

UE 1/0/4
MOQ 4
▶ mm 3
✂ mm



Baguette S

INOX 18/10 / 2mm / Mirror

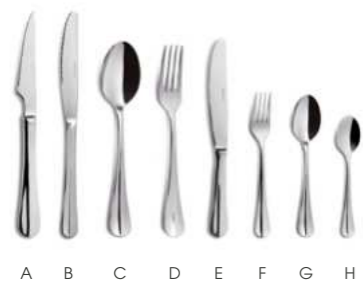

INOX
STAINLESS
STEEL
304

- A **1283** CUCHILLO CHULETERO
steak knife, couteau steak, coltello bistecca, steakmesser
- B **3522** CUCHILLO MESA
table knife, couteau table, coltello tavola, tafelmesser
- C **4377** CUCHARA MESA
table spoon, cuillère table, cucchiaio tavola, tafellöffel
- D **4378** TENEDOR MESA
table fork, fourchette table, forchetta tavola, tafelgabel
- E **3523** CUCHILLO POSTRE
dessert knife, couteau dessert, coltello frutta, dessertmesser
- F **4383** TENEDOR LUNCH
cake fork, fourchette gâteau, forchetta dolce, kuchengabel
- G **4384** CUCHARA CAFÉ
tea spoon, cuillère café, cucchiaio caffè, kaffeelöffel
- H **4385** CUCHARA MOKA
coffee/moka spoon, cuillère moka, cucchiaio moka, mokkalöffel

7121 24 PIEZAS
24 pieces, écriin 24 pièces, bauletto 24 pz, 24 stück

| UE | MOQ | ▶ mm | ✂ mm |
|---------------------|-----|------|------|
| 0/12/120/1920/5760 | 60 | 223 | |
| 0/12/120/1920/5760 | 60 | 225 | |
| 0/12/120/1440/7200 | 60 | 193 | 1,8 |
| 0/12/120/1440/7200 | 60 | 190 | 2 |
| 0/12/120/1920/5760 | 60 | 196 | |
| 0/12/120/2520/15120 | 60 | 143 | 1,5 |
| 0/12/120/2520/15120 | 60 | 140 | 1,5 |
| 0/12/120/2520/15120 | 60 | 120 | 1,2 |
| 1/0/4 | 4 | | 2 |



UP
GRADE

Actualización / Upgrade

NORTH XL / BAGUETTE XL / INGLÉS XL



2024



2025

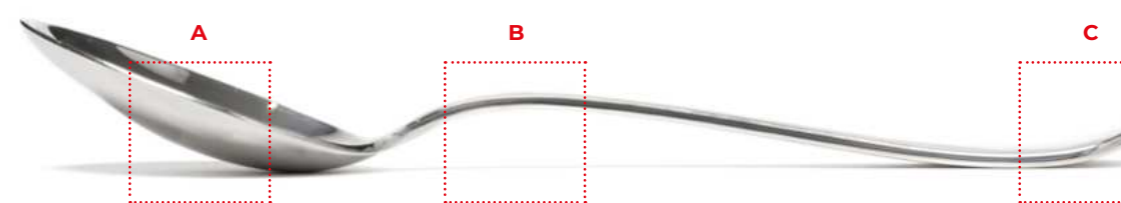

Profundidad pala.
Shovel depth.

Curvatura cuello.
Neck curvature.

Curvatura talón.
Heel curvature

PROFUNDIDAD DE LA PALA / SHOVEL DEPTH

Se ha aumentado la profundidad en la pala, permitiendo contener más líquido o alimentos y proporcionando así una mayor comodidad al usuario al permanecer la comida más estable dentro de la cuchara, sin derramarse.

The depth of the scoop has been increased, allowing it to hold more liquid or food and thus providing greater comfort to the user as the food remains more stable inside the spoon, without spilling.

CURVATURA DEL CUELLO / NECK CURVATURE

Diseñada para mejorar la ergonomía. Facilita el movimiento natural de la mano al llevar la comida a la boca, haciendo que el gesto sea más cómodo y fluido.

Designed to improve ergonomics. Facilitates the natural movement of the hand when bringing food to the mouth, making the gesture more comfortable and fluid.

CURVATURA DEL TALÓN / HEEL CURVATURE

Curvatura del talón más pronunciada que mejora el balance de la cuchara en la mano dando una sensación de mayor estabilidad.

More pronounced heel curvature improves the balance of the scoop in the hand giving a more stable feel.

Inglés XL

INOX 18/10 / 3mm / Mirror



Inglés XL

INOX 18/10 / 3mm / Mirror

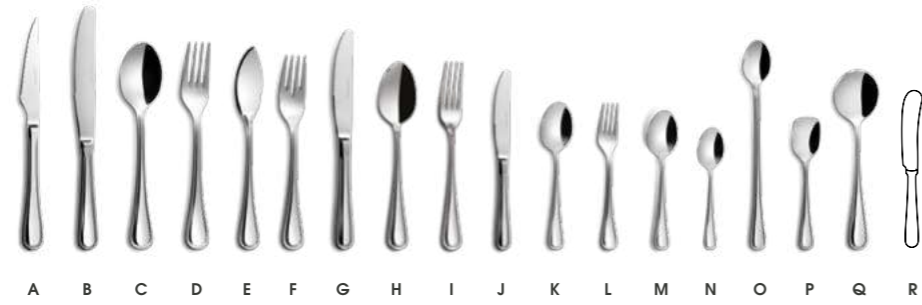

INOX STAINLESS STEEL 304

- A **5952** CUCHILLO CHULETERO
steak knife, couteau steak, coltello bistecca, steakmesser
- NEW** B **11917** CUCHILLO MESA CLASICO
classic table knife, couteau table classic, coltello tavola classic, tafelmesser classic
- NEW** C **11918** CUCHARA MESA
table spoon, cuillère table, cucchiaio tavola, tafellöffel
- NEW** D **11919** TENEDOR MESA
table fork, fourchette table, forchetta tavola, tafelgabel
- E **5372** PALA PESCADO
fish knife, couteau poisson, coltello pesce, fischmesser
- F **5373** TENEDOR PESCADO
fish fork, fourchette poisson, forchetta pesce, fischgabel
- NEW** G **11920** CUCHILLO POSTRE CLASICO
classic dessert knife, couteau dessert classic, coltello frutta classic, dessertmesser classic
- H **5374** CUCHARA POSTRE
dessert spoon, cuillère dessert, cucchiaio frutta, dessertlöffel
- I **5375** TENEDOR POSTRE
dessert fork, fourchette dessert, forchetta frutta, dessertgabel
- NEW** J **11921** CUCHILLO LUNCH CLASICO
classic cake knife, couteau gâteau classic, coltello dolce classic, kuchenmesser classic
- UP** K **5309** CUCHARA TÉ
tea spoon, cuillère à té, cucchiaio the, cocktaillöffel
- NEW** L **11922** TENEDOR LUNCH
cake fork, fourchette gâteau, forchetta dolce, kuchengabel
- UP** M **5437** CUCHARA CAFÉ
tea spoon, cuillère café, cucchiaio caffè, kaffeelöffel
- UP** N **5438** CUCHARA MOKA
coffee/moka spoon, cuillère moka, cucchiaio moka, mokkalöffel
- O **4508** CUCHARA REFRESCO
soda spoon, cuillère mazagan, cucchiaio bibita, longdrinklöffel
- P **4018** CUCHARA HELADO
ice cream spoon, cuillère à glace, cucchiaio gelato, eiscremelöffel
- Q **4019** CUCHARA CONSOMÉ
consommé spoon, cuillère consommé, cucchiaio zuppa, bouillonlöffel
- NEW** R **12029** PALA MANTEQUILLA
butter knife, cuillère consommé, cucchiaio zuppa, bouillonlöffel

| UE | MOQ | ▶ mm | ✂ mm |
|---------------------|-----|------|------|
| 0/12/120/1920/5760 | 60 | 228 | |
| 0/12/120/1920/5760 | 60 | 240 | |
| 0/12/120/1440/7200 | 60 | 209 | 3 |
| 0/12/120/1440/7200 | 60 | 210 | 3 |
| 0/12/120/1440/7200 | 60 | 200 | 2,5 |
| 0/12/120/1440/7200 | 60 | 195 | 2,5 |
| 0/12/120/1440/7200 | 60 | 217 | |
| 0/12/120/1440/7200 | 60 | 178 | 2,5 |
| 0/12/120/1440/7200 | 60 | 183 | 2,5 |
| 0/12/120/2520/15120 | 60 | 177 | |
| 0/12/120/1440/7200 | 60 | 145 | 2 |
| 0/12/120/2520/15120 | 60 | 148 | 2 |
| 0/12/120/2520/15120 | 60 | 138 | 2 |
| 0/12/120/2520/15120 | 60 | 117 | 2 |
| 0/12/120/1440/7200 | 60 | 207 | 2 |
| 0/12/120/2520/15120 | 60 | 130 | 2 |
| 0/12/120/1440/7200 | 60 | 180 | 2,5 |
| 0/12/120/2520/15120 | 60 | 176 | |



4881 24 PIEZAS
24 pieces, écrin 24 pièces, bauletto 24 pz., 24 stück

| UE | MOQ | ▶ mm | ✂ mm |
|-------|-----|------|------|
| 1/0/4 | 4 | | 2,5 |



Inglés M

INOX 18/10 / 2,5mm / Mirror



Inglés S

INOX 18/10 / 2mm / Mirror

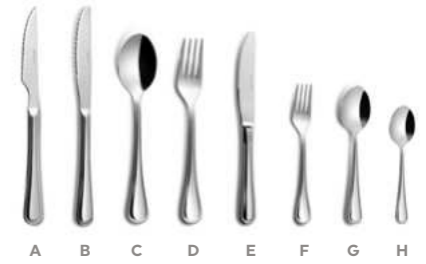

INOX STAINLESS STEEL 304

- A **6360** CUCHILLO MESA GRANDE
long table knife, grande couteau table, coltello tavola grande, tafelmesser lang
- B **4009** CUCHARA MESA GRANDE
long table spoon, grande cuillère table, cucchiaio tavola grande, tafellöffel lang
- C **4010** TENEDOR MESA GRANDE
long table fork, grande fourchette table, forchetta tavola grande, tafelgabel lang
- D **5437** CUCHARA CAFÉ
tea spoon, cuillère café, cucchiaio caffè, kaffeelöffel

7123 24 PIEZAS
24 pieces, écrin 24 pièces, bauletto 24 pz., 24 stück

UE **MOQ** **▶ mm** **✂ mm**

| | | | |
|---------------------|----|-----|-----|
| 0/12/120/1920/5760 | 60 | 228 | |
| 0/12/120/1440/7200 | 60 | 198 | 2,5 |
| 0/12/120/1440/7200 | 60 | 198 | 2,5 |
| 0/12/120/2520/15120 | 60 | 137 | 2 |



INOX STAINLESS STEEL 304

- A **2396** CUCHILLO CHULETERO
steak knife, couteau steak, coltello bistecca, steakmesser
- B **2338** CUCHILLO MESA
table knife, couteau table, coltello tavola, tafelmesser
- C **2339** CUCHARA MESA
table spoon, cuillère table, cucchiaio tavola, tafellöffel
- D **2340** TENEDOR MESA
table fork, fourchette table, forchetta tavola, tafelgabel
- E **2511** CUCHILLO POSTRE
dessert knife, couteau dessert, coltello frutta, dessertmesser
- F **2341** TENEDOR LUNCH
cake fork, fourchette gâteau, forchetta dolce, kuchengabel
- G **2342** CUCHARA CAFÉ
tea spoon, cuillère café, cucchiaio caffè, kaffeelöffel
- H **2343** CUCHARA MOKA
coffee/moka spoon, cuillère moka, cucchiaio moka, mokkalöffel

7124 24 PIEZAS
24 pieces, écrin 24 pièces, bauletto 24 pz., 24 stück

UE **MOQ** **▶ mm** **✂ mm**

| | | | |
|---------------------|----|-----|-----|
| 0/12/120/1920/5760 | 60 | 223 | |
| 0/12/120/1920/5760 | 60 | 222 | |
| 0/12/120/1440/7200 | 60 | 193 | 1,8 |
| 0/12/120/1440/7200 | 60 | 190 | 2 |
| 0/12/120/1920/5760 | 60 | 196 | |
| 0/12/120/2520/15120 | 60 | 143 | 1,5 |
| 0/12/120/2520/15120 | 60 | 140 | 1,5 |
| 0/12/120/2520/15120 | 60 | 120 | 1,2 |





INOX
STAINLESS
STEEL
304

| | | |
|---|-------------|---|
| A | 5307 | CUCHILLO CHULETERO steak knife, couteau steak, coltello bistecca, steakmesser |
| B | 4777 | CUCHILLO MESA table knife, couteau table, coltello tavola, tafelmesser |
| C | 4714 | CUCHARA MESA table spoon, cuillère table, cucchiaio tavola, tafellöffel |
| D | 4715 | TENEDOR MESA table fork, fourchette table, forchetta tavola, tafelgabel |
| E | 4716 | PALA PESCADO fish knife, couteau poisson, coltello pesce, fischmesser |
| F | 4717 | TENEDOR PESCADO fish fork, fourchette poisson, forchetta pesce, fischgabel |
| G | 4778 | CUCHILLO POSTRE dessert knife, couteau dessert, coltello frutta, dessertmesser |
| H | 4721 | CUCHARA POSTRE dessert spoon, cuillère dessert, cucchiaio frutta, dessertlöffel |
| I | 4722 | TENEDOR POSTRE dessert fork, fourchette dessert, forchetta frutta, dessertgabel |
| J | 4718 | TENEDOR LUNCH cake fork, fourchette gâteau, forchetta dolce, kuchengabel |
| K | 4719 | CUCHARA CAFÉ tea spoon, cuillère café, cucchiaio caffè, kaffeelöffel |
| L | 4720 | CUCHARA MOKA coffee/moka spoon, cuillère moka, cucchiaio moka, mokkalöffel |
| M | 4781 | CAZO SOPA soup ladle, louche à potage, mestolo, suppenkelle |
| N | 4780 | CUCHARA ENSALADA salad spoon, cuillère à servir salade, cucchiaio servire, salatlöffel |
| O | 4779 | TENEDOR ENSALADA salad fork, fourchette à servir salade, forchetta servire, salatgabel |
| P | 4784 | PALA REPOSTERÍA cake server, pelle à tarte, pala torta, tortenheber |
| Q | 4783 | CAZO SALSA sauce ladle, cuillère à sauce, mestolino salsa, soßenkelle |

| UE | MOQ | ◀ mm | ✂ mm |
|---------------------|-----|------|------|
| 0/12/120/1920/5760 | 60 | 228 | |
| 0/12/120/1920/5760 | 60 | 240 | |
| 0/12/120/1440/7200 | 60 | 210 | 2,5 |
| 0/12/120/1440/7200 | 60 | 210 | 2,5 |
| 0/12/120/1440/7200 | 60 | 210 | 2,5 |
| 0/12/120/1440/7200 | 60 | 196 | 2,5 |
| 0/12/120/1920/5760 | 60 | 210 | |
| 0/12/120/1440/7200 | 60 | 191 | 2,5 |
| 0/12/120/1440/7200 | 60 | 195 | 2,5 |
| 0/12/120/2520/15120 | 60 | 160 | 2 |
| 0/12/120/2520/15120 | 60 | 155 | 2 |
| 0/12/120/2520/15120 | 60 | 133 | 1,8 |
| 1/10/50/150/750 | 10 | 280 | 2,5 |
| 1/10/50/800/4000 | 10 | 240 | 2,5 |
| 1/10/50/800/4000 | 10 | 240 | 2,5 |
| 1/10/50/800/2400 | 10 | 240 | 2,5 |
| 1/10/50/800/4000 | 10 | 170 | 2,7 |



9817 24 PIEZAS
24 pièces, écriin 24 pièces, bauletto 24 pz., 24 stück

| UE | MOQ | ◀ mm | ✂ mm |
|-------|-----|------|------|
| 1/0/4 | 4 | | 2,5 |



Barcelona

INOX 18/10 / 3,5mm / Mirror



Barcelona

INOX 18/10 / 3,5mm / Mirror



INOX STAINLESS STEEL 304

- A **0764** CUCHILLO CHULETERO
steak knife, couteau steak, coltello bistecca, steakmesser
- B **0268** CUCHILLO MESA
table knife, couteau table, coltello tavola, tafelmesser
- NEW** C **11913** CUCHARA MESA
table spoon, cuillère table, cucchiaio tavola, tafellöffel
- NEW** D **11914** TENEDOR MESA
table fork, fourchette table, forchetta tavola, tafelgabel
- E **5805** PALA PESCADO
fish knife, couteau poisson, coltello pesce, fischmesser
- F **5806** TENEDOR PESCADO
fish fork, fourchette poisson, forchetta pesce, fischgabel
- G **5807** CUCHILLO POSTRE
dessert knife, couteau dessert, coltello frutta, dessertmesser
- H **5808** CUCHARA POSTRE
dessert spoon, cuillère dessert, cucchiaio frutta, dessertlöffel
- I **5809** TENEDOR POSTRE
dessert fork, fourchette dessert, forchetta frutta, dessertgabel
- J **5814** CUCHILLO LUNCH
cake knife, couteau gâteau, coltello dolce, kuchenmesser
- K **5810** TENEDOR LUNCH
cake fork, fourchette gâteau, forchetta dolce, kuchengabel
- L **5811** CUCHARA CAFÉ
tea spoon, cuillère café, cucchiaio caffè, kaffeeöffel
- M **5812** CUCHARA MOKA
coffee/moka spoon, cuillère moka, cucchiaio moka, mokkalöffel
- N **5815** PALA MANTEQUILLA
butter knife, couteau beurre, coltello burro, buttermesser
- O **3152** CUCHARA REFRESCO
soda spoon, cuillère mazagran, cucchiaio bibita, longdrinklöffel
- P **3153** CUCHARA CONSOMÉ
consommé spoon, cuillère consommé, cucchiaio zuppa, bouillonlöffel
- Q **0470** CAZO SOPA
soup ladle, louche à potage, mestolo, suppenkelle
- R **0471** CUCHARA ENSALADA
salad spoon, cuillère à servir salade, cucchiaio servire, salatlöffel
- S **0472** TENEDOR ENSALADA
salad fork, fourchette à servir salade, forchetta servire, salatgabel
- T **0473** PALA LASAÑA
lasagna server, pelle à lasagne, pala lasagna, lasagneheber
- U **0474** CAZO SALSA
sauce ladle, cuillère à sauce, mestolino salsa, soßenkelle

| UE | MOQ | mm | mm |
|---------------------|-----|-----|-----|
| 0/12/120/1920/5760 | 60 | 223 | |
| 0/12/120/1920/5760 | 60 | 221 | |
| 0/12/120/1440/7200 | 60 | 200 | 3,5 |
| 0/12/120/1440/7200 | 60 | 200 | 3,5 |
| 0/12/120/1440/7200 | 60 | 205 | 2,5 |
| 0/12/120/1440/7200 | 60 | 190 | 2,5 |
| 0/12/120/1920/5760 | 60 | 202 | |
| 0/12/120/1440/7200 | 60 | 183 | 2,5 |
| 0/12/120/1440/7200 | 60 | 185 | 2,5 |
| 0/12/120/1920/5760 | 60 | 167 | |
| 0/12/120/2520/15120 | 60 | 140 | 2,5 |
| 0/12/120/2520/15120 | 60 | 140 | 2,5 |
| 0/12/120/2520/15120 | 60 | 110 | 2,5 |
| 0/12/120/1440/7200 | 60 | 165 | 2,5 |
| 0/12/120/1440/7200 | 60 | 200 | 2,5 |
| 0/12/120/1440/7200 | 60 | 180 | 2,5 |
| 1/10/50/150/750 | 10 | 268 | 3 |
| 1/10/50/800/4000 | 10 | 270 | 3 |
| 1/10/50/800/4000 | 10 | 265 | 3 |
| 1/10/50/600/2400 | 10 | 235 | 3 |
| 1/10/50/800/4000 | 10 | 180 | 3 |



5818 24 PIEZAS
24 pieces, écrin 24 pièces, bauletto 24 pz, 24 stück

UE 1/0/4
MOQ 4
mm 3
mm 3





Soporte cubiertos Sakura
Sakura cutlery holder
Panier à couverts Sakura
Supporto coperte Sakura
Besteckhalter Sakura



INOX
STAINLESS
STEEL
304

| REF. | W _(mm) | H _(mm) | € | UE / MOQ |
|------|-------------------|-------------------|---|-----------------------|
| 7869 | 80 | 8,5 | | 0-6-60-1440-4320 / 60 |



Reposacubiertos Atlántida
Atlantida cutlery holder
Panier à couverts Atlantida
Porta posate Atlantida
Besteckhalter Atlantida



INOX
STAINLESS
STEEL
304

| REF. | W _(mm) | H _(mm) | € | UE / MOQ |
|-------|-------------------|-------------------|---|----------------------|
| 10431 | 190 | 1,5 | | 1-4--48-624-1248 / 4 |



Reposacubiertos Ice Kyoto
Kyoto ice cutlery holder
Repose à couverts ice Kyoto
Supporto posate ice Kyoto
Messerablage ice Kyoto



INOX
STAINLESS
STEEL
304

| REF. | W _(mm) | H _(mm) | € | UE / MOQ |
|-------|-------------------|-------------------|---|----------------|
| 11013 | 80 | 8,5 | | 0-4-40-0-0 / 4 |



Reposapalillos bloque satin
Chopsticks holder satin
Porte baguette satin
Supporto posate satin
Besteckhalter satin



INOX
STAINLESS
STEEL
304

| REF. | W _(mm) | H _(mm) | € | UE / MOQ |
|--------|-------------------|-------------------|---|-------------------------|
| ● 7554 | 60 | 8 | | 0-12-120-1920-5760 / 12 |
| ● 7555 | 60 | 8 | | 0-12-120-1920-5760 / 12 |

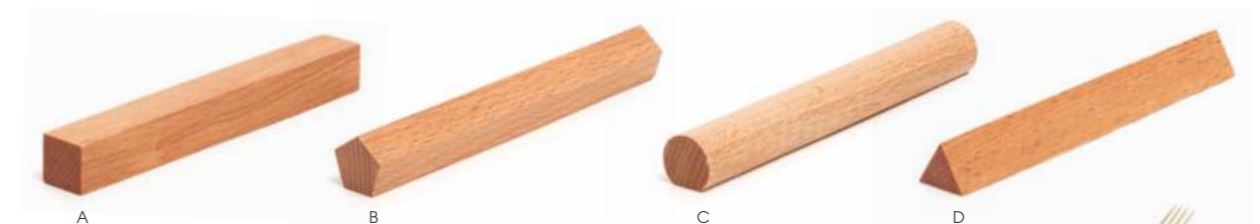

Reposacubiertos
Cutlery holder
Repose couverts
Supporto posate
Messerablage



BEECH
WOOD

| REF. | W _(mm) | H _(mm) | € | UE / MOQ |
|--------|-------------------|-------------------|---|-------------------------|
| A 7843 | 122 | 8,5 | | 1-60-240-3840-10080 / 6 |
| B 7844 | 122 | 8,5 | | 1-60-240-3360-10080 / 6 |
| C 7841 | 122 | 8,5 | | 1-60-240-3360-10080 / 6 |
| D 7842 | 122 | 8,5 | | 1-60-240-3360-10080 / 6 |



GLASS

Vidrio texturizado de manera manual. Cada pieza es única y exclusiva.

Hand-textured glass. Each piece is unique and exclusive.



Vidrio ligero y resistente. Diseño que facilitan la apilabilidad.

Lightweight and resistant glass and stackable design.

VELVET FINISH

Acabado superficial de partículas metálicas que le da un aspecto terciopelado.

Surface finish of metallic particles that gives it a velvety appearance.



| | | UE | MOQ | Lmm | Wmm |
|---|--|-------|-----|-----|-----|
| A | 11957 REPOSACUBIERTOS MUNA VELVET ORO muna velvet cutlery rest gold, repose-couverts muna velvet or, portaposate muna velvet oro, besteckhalter muna velvet gold | 0/4/0 | 4 | 100 | 25 |
| B | 11958 REPOSACUBIERTOS MUNA VELVET VERDE muna velvet cutlery rest green, repose-couverts muna velvet vert, portaposate muna velvet, verde besteckhalter muna velvet grün | 0/4/0 | 4 | 100 | 25 |
| C | 11962 REPOSACUBIERTOS OVAL VELVET ORO oval velvet cutlery rest gold, repose-couverts oval velvet or, portaposate ovale velvet oro, ovaler besteckhalter velvet gold | 0/4/0 | 4 | 70 | 30 |
| D | 11963 REPOSACUBIERTOS OVAL VELVET VERDE oval velvet cutlery rest green, repose-couverts oval velvet vert, portaposate ovale velvet verde, ovaler besteckhalter velvet grün | 0/4/0 | 4 | 70 | 30 |

Conoce LUESMA & VEGA en la página: 504
More about LUESMA & VEGA in page: 504

GLASS

Reposacubiertos / Cristal
Cutlery holder/ Glass



| | | UE | MOQ | Lmm | Wmm |
|---|--|-------|-----|-----|-----|
| A | 11959 CUCHARA MUNA VELVET ORO muna velvet spoon gold, culliere muna velvet or, cucchiaino muna velvet oro, löffel muna velvet gold | 0/4/0 | 4 | 100 | 30 |
| B | 11960 CUCHARA MUNA VELVET VERDE muna velvet spoon green, repose-couverts muna velvet vert, portaposate muna velvet verde, besteckhalter muna velvet grün | 0/4/0 | 4 | 100 | 30 |
| C | 11961 CUCHARA MUNA BLANCO muna velvet spoon white, repose-couverts muna velvet or, portaposate muna velvet oro, besteckhalter muna velvet gold | 0/4/0 | 4 | 100 | 30 |

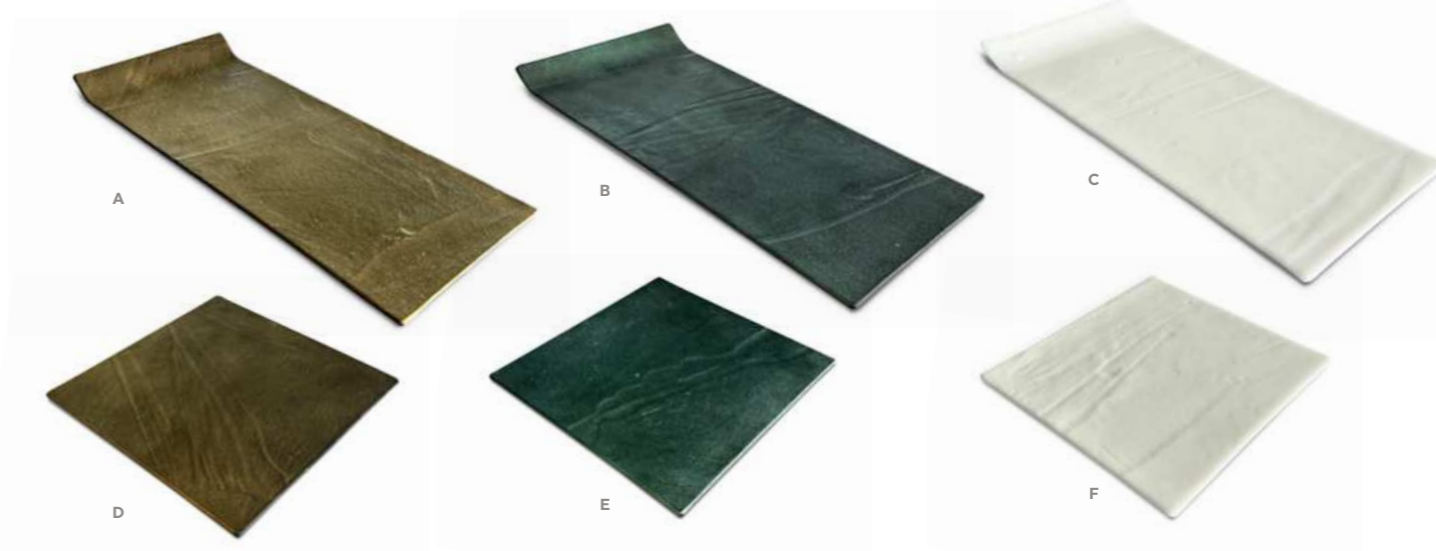

| | | UE | MOQ | Lmm | Wmm |
|---|---|-------|-----|-----|-----|
| A | 12008 SOPORTE CUCHARA MUNA VELVET ORO muna velvet cutlery rest gold, repose-couverts muna velvet or, portaposate muna velvet oro, besteckhalter muna velvet gold | 0/2/0 | 2 | 110 | 25 |
| B | 12009 SOPORTE CUCHARA MUNA VELVET VERDE muna velvet cutlery rest green, repose-couverts muna velvet vert, portaposate muna velvet verde, besteckhalter muna velvet grün | 0/2/0 | 2 | 110 | 25 |
| C | 12010 SOPORTE CUCHARA MUNA BLANCO muna velvet cutlery rest white, repose-couverts muna velvet or, portaposate muna velvet bianco, besteckhalter muna velvet gold | 0/2/0 | 2 | 110 | 25 |
| D | 12011 SOPORTE CUCHARA MUNA VELVET ORO muna velvet cutlery rest gold, repose-couverts muna velvet or, portaposate muna velvet oro, besteckhalter muna velvet gold | 0/2/0 | 2 | 150 | 15 |
| E | 12012 SOPORTE CUCHARA MUNA VELVET VERDE muna velvet cutlery rest gold repose-couverts muna velvet or portaposate muna velvet oro besteckhalter muna velvet gold | 0/2/0 | 2 | 150 | 15 |
| F | 12013 SOPORTE CUCHARA MUNA BLANCO muna velvet cutlery rest white repose-couverts muna velvet vert portaposate muna velvet verde besteckhalter muna velvet grün | 0/2/0 | 2 | 150 | 15 |

Bcn Satin



INOX Nickel Free 18% / 3mm / Satin



Bcn Satin

INOX Nickel Free 18% / 3mm / Satin



INOX
STAINLESS
STEEL
430

| | | UE | MOQ | ✂ mm | ✂ mm |
|------------|---|---------------------|-----|------|------|
| A | 6721 CUCHILLO MESA table knife, couteau table, coltello tavola, tafelmesser | 1/12/120/1920/5760 | 120 | 221 | |
| B | 6722 CUCHARA MESA table spoon, cuillère table, cucchiaio tavola, tafellöffel | 1/12/120/1440/7200 | 120 | 200 | 3 |
| C | 6723 TENEDOR MESA table fork, fourchette table, forchetta tavola, tafelgabel | 1/12/120/1440/7200 | 120 | 200 | 3 |
| D | 6724 CUCHILLO POSTRE dessert knife, couteau dessert, coltello frutta, dessertmesser | 1/12/120/1920/5760 | 120 | 202 | |
| E | 6725 CUCHARA POSTRE dessert spoon, cuillère dessert, cucchiaio frutta, dessertlöffel | 1/12/120/1440/7200 | 120 | 183 | 2,5 |
| F | 6726 TENEDOR POSTRE dessert fork, fourchette dessert, forchetta frutta, dessertgabel | 1/12/120/1440/7200 | 120 | 185 | 2,5 |
| G | 6727 TENEDOR LUNCH cake fork, fourchette gâteau, forchetta dolce, kuchengabel | 1/12/120/2520/15120 | 120 | 140 | 2,5 |
| H | 6728 CUCHARA CAFÉ tea spoon, cuillère café, cucchiaio caffè, kaffeelöffel | 1/12/120/2520/15120 | 120 | 140 | 2,5 |
| I | 6729 CUCHARA MOKA moka spoon, cuillère moka, cucchiaio moka, mokkalöffel | 1/12/120/2520/15120 | 120 | 110 | 2,5 |
| J | 8378 CUCHARA REFRESCO soda spoon, cuillère mazagran, cucchiaio bibita, longdrinklöffel | 1/12/120/1440/7200 | 60 | 202 | |
| K | 8796 CUCHARA APERITIVO appetizer spoon, cuillère apéritif, cucchiaio antipasto, aperitif löffe | 0/6/60/1440/4320 | 60 | 132 | 3 |
| NEW | 1051 BLISTER 3 CUCHILLO MESA blister 3 table knife, blister 3 couteau table, blister 3 coltello tavola, blister 3 tafelmesser | 1/0/12/0/0 | 12 | | |
| NEW | 1052 BLISTER 6 CUCHARA MESA blister 6 table spoon, blister 6 cuillère table, blister 6 cucchiaio tavola, blister 6 tafellöffel | 1/0/12/0/0 | 12 | | |
| NEW | 1053 BLISTER 6 TENEDOR MESA blister 6 table fork, blister 6 fourchette table, blister 6 forchetta tavola, blister 6 tafelgabel | 1/0/12/0/0 | 12 | | |
| NEW | 1055 BLISTER 6 TENEDOR LUNCH blister 6 cake fork, blister 6 fourchette gâteau, blister 6 forchetta dolce, blister 6 kuchengabel | 1/0/12/0/0 | 12 | | |
| NEW | 1054 BLISTER 6 CUCHARA CAFÉ blister 6 tea spoon, blister 6 cuillère café, blister 6 cucchiaio caffè, blister 6 kaffeelöffel | 1/0/12/0/0 | 12 | | |
| NEW | 1056 BLISTER 6 CUCHARA MOKA blister 6 coffee/moka spoon, blister 6 cuillère moka, blister 6 cucchiaio moka, blister 6 mokkalöffel | 1/0/12/0/0 | 12 | | |
| | 6730 24 PIEZAS 24 pieces, écrin 24 pièces, bauletto 24 pz., 24 Stück | 1/0/4 | 4 | | 3 |

Bcn Satin Gold

INOX Nickel Free 18% / 3mm / Satin



INOX STAINLESS STEEL 430

| | | UE | MOQ | ✂ mm | ✂ mm |
|--------------|---|---------------------|-----|------|------|
| A | 6096 CUCHILLO MESA table knife, couteau table, coltello tavola, tafelmesser | 1/12/120/1920/5760 | 60 | 221 | |
| B | 6097 CUCHARA MESA table spoon, cuillère table, cucchiaio tavola, tafellöffel | 1/12/120/1440/7200 | 60 | 200 | 3 |
| C | 6098 TENEDOR MESA table fork, fourchette table, forchetta tavola, tafelgabel | 1/12/120/1440/7200 | 60 | 200 | 3 |
| NEW D | 11906 PALA PESCADO fish knife, couteau poisson, coltello pesce, fischmesser | 1/12/120/1440/7200 | 60 | 206 | 2,5 |
| NEW E | 11907 TENEDOR PESCADO fish fork, fourchette poisson, forchetta pesce, fischgabel | 1/12/120/1440/7200 | 60 | 187 | 2,5 |
| F | 6350 CUCHILLO POSTRE dessert knife, couteau dessert, coltello frutta, dessertmesser | 1/12/120/1920/5760 | 60 | 202 | |
| G | 6351 CUCHARA POSTRE dessert spoon, cuillère dessert, cucchiaio frutta, dessertlöffel | 1/12/120/1440/7200 | 60 | 183 | 2,5 |
| H | 6352 TENEDOR POSTRE dessert fork, fourchette dessert, forchetta frutta, dessertgabel | 1/12/120/1440/7200 | 60 | 185 | 2,5 |
| I | 6099 TENEDOR LUNCH cake fork, fourchette gâteau, forchetta dolce, kuchengabel | 1/12/120/2520/15120 | 60 | 140 | 2,5 |
| J | 6100 CUCHARA CAFÉ tea spoon, cuillère café, cucchiaio caffè, kaffeelöffel | 1/12/120/2520/15120 | 60 | 140 | 2,5 |
| K | 6101 CUCHARA MOKA coffee/moka spoon, cuillère moka, cucchiaio moka, mokkalöffel | 1/12/120/2520/15120 | 60 | 110 | 2,5 |
| L | 7551 CUCHARA REFRESCO soda spoon, cuillère mazagran, cucchiaio bibita, longdrinklöffel | 1/12/120/1440/7200 | 60 | 202 | 2,5 |
| M | 7902 CUCHARA ENSALADA salad spoon, cuillère à servir salade, cucchiaio servire, salatlöffel | 1/10/50/800/4000 | 10 | 270 | 3 |
| N | 7903 TENEDOR ENSALADA salad fork, fourchette à servir salade, forchetta servire, salatgabel | 1/10/50/800/4000 | 10 | 265 | 3 |
| O | 8797 CUCHARA APERITIVO appetizer spoon, cuillère apéritif, cucchiaio antipasto, aperitif löffel | 0/6/60/1440/4320 | 60 | 132 | 3 |
| 6324 | 24 PIEZAS 24 pieces, écriin 24 pièces, bauletto 24 pz., 24 stück | 1/0/4 | 4 | | 3 |



Bcn Satin Copper

INOX Nickel Free 18% / 3mm / Satin



INOX STAINLESS STEEL 430

| | | UE | MOQ | ✂ mm | ✂ mm |
|--------------|---|---------------------|-----|------|------|
| A | 6108 CUCHILLO MESA table knife, couteau table, coltello tavola, tafelmesser | 1/12/120/1920/5760 | 60 | 221 | |
| B | 6109 CUCHARA MESA table spoon, cuillère table, cucchiaio tavola, tafellöffel | 1/12/120/1440/7200 | 60 | 200 | 3 |
| C | 6110 TENEDOR MESA table fork, fourchette table, forchetta tavola, tafelgabel | 1/12/120/1440/7200 | 60 | 200 | 3 |
| NEW D | 11908 PALA PESCADO fish knife, couteau poisson, coltello pesce, fischmesser | 1/12/120/1440/7200 | 60 | 206 | 2,5 |
| NEW E | 11909 TENEDOR PESCADO fish fork, fourchette poisson, forchetta pesce, fischgabel | 1/12/120/1440/7200 | 60 | 187 | 2,5 |
| F | 6356 CUCHILLO POSTRE dessert knife, couteau dessert, coltello frutta, dessertmesser | 1/12/120/1920/5760 | 60 | 202 | 2,5 |
| G | 6357 CUCHARA POSTRE dessert spoon, cuillère dessert, cucchiaio frutta, dessertlöffel | 1/12/120/1440/7200 | 60 | 183 | 2,5 |
| H | 6358 TENEDOR POSTRE dessert fork, fourchette dessert, forchetta frutta, dessertgabel | 1/12/120/1440/7200 | 60 | 185 | 2,5 |
| I | 6111 TENEDOR LUNCH cake fork, fourchette gâteau, forchetta dolce, kuchengabel | 1/12/120/2520/15120 | 60 | 140 | 2,5 |
| J | 6112 CUCHARA CAFÉ tea spoon, cuillère café, cucchiaio caffè, kaffeelöffel | 1/12/120/2520/15120 | 60 | 140 | 2,5 |
| K | 6113 CUCHARA MOKA coffee/moka spoon, cuillère moka, cucchiaio moka, mokkalöffel | 1/12/120/2520/15120 | 60 | 110 | 2,5 |
| L | 7553 CUCHARA REFRESCO soda spoon, cuillère mazagran, cucchiaio bibita, longdrinklöffel | 1/12/120/1440/7200 | 60 | 202 | 2,5 |
| O | 8799 CUCHARA APERITIVO appetizer spoon, cuillère apéritif, cucchiaio antipasto, aperitif löffel | 0/6/60/1440/4320 | 60 | 132 | 3 |
| M | 7965 CUCHARA ENSALADA salad spoon, cuillère à servir salade, cucchiaio servire, salatlöffel | 1/10/50/800/4000 | 10 | 270 | 3 |
| N | 7966 TENEDOR ENSALADA salad fork, fourchette à servir salade, forchetta servire, salatgabel | 1/10/50/800/4000 | 10 | 265 | 3 |
| NEW | 5314 BLISTER 3 CUCHILLO MESA blister 3 table knife, blister 3 couteau table, blister 3 coltello tavola, blister 3 tafelmesser | 1/0/12/0/0 | 12 | | |
| NEW | 5315 BLISTER 6 CUCHARA MESA blister 6 table spoon, blister 6 cuillère table, blister 6 cucchiaio tavola, blister 6 tafellöffel | 1/0/12/0/0 | 12 | | |
| NEW | 5316 BLISTER 6 TENEDOR MESA blister 6 table fork, blister 6 fourchette table, blister 6 forchetta tavola, blister 6 tafelgabel | 1/0/12/0/0 | 12 | | |
| NEW | 1057 BLISTER 6 TENEDOR LUNCH blister 6 cake fork, blister 6 fourchette gâteau, blister 6 forchetta dolce, blister 6 kuchengabel | 1/0/12/0/0 | 12 | | |
| NEW | 5317 BLISTER 6 CUCHARA CAFÉ blister 6 tea spoon, blister 6 cuillère café, blister 6 cucchiaio caffè, blister 6 kaffeelöffel | 1/0/12/0/0 | 12 | | |
| NEW | 1058 BLISTER 6 CUCHARA MOKA blister 6 coffee/moka spoon, blister 6 cuillère moka, blister 6 cucchiaio moka, blister 6 mokkalöffel | 1/0/12/0/0 | 12 | | |
| 6325 | 24 PIEZAS 24 pieces, écriin 24 pièces, bauletto 24 pz., 24 stück | 1/0/4 | 4 | | 3 |



Bcn Satin Champagne

INOX Nickel Free 18% / 3mm / Satin

Bcn Satin Black

INOX Nickel Free 18% / 3mm / Satin

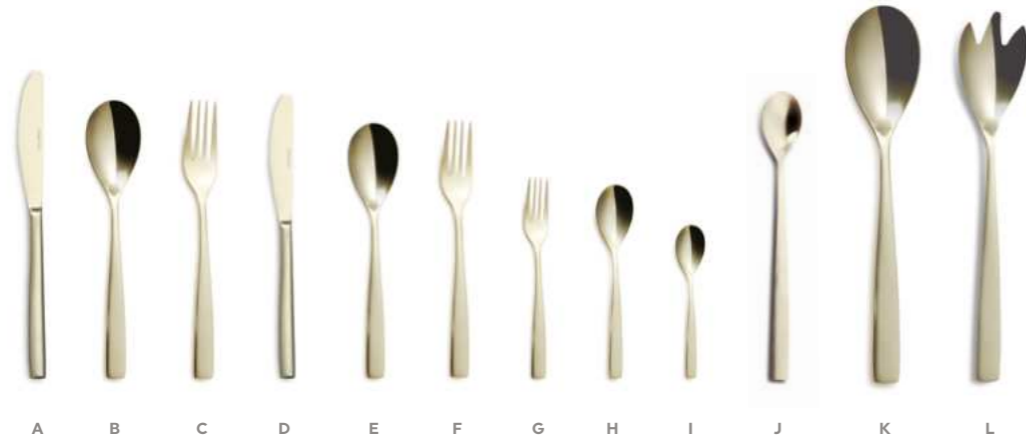

INOX
STAINLESS
STEEL
430

| | | UE | MOQ | ✂ mm | ✂ mm |
|-------------|---|---------------------|-----|------|------|
| A | 6711 CUCHILLO MESA table knife, couteau table, coltello tavola, tafelmesser | 1/12/120/1920/5760 | 60 | 221 | |
| B | 6712 CUCHARA MESA table spoon, cuillère table, cucchiaio tavola, tafellöffel | 1/12/120/1440/7200 | 60 | 200 | 3 |
| C | 6713 TENEDOR MESA table fork, fourchette table, forchetta tavola, tafelgabel | 1/12/120/1440/7200 | 60 | 200 | 3 |
| D | 6714 CUCHILLO POSTRE dessert knife, couteau dessert, coltello frutta, dessertmesser | 1/12/120/1920/5760 | 60 | 202 | |
| E | 6715 CUCHARA POSTRE dessert spoon, cuillère dessert, cucchiaio frutta, dessertlöffel | 1/12/120/1440/7200 | 60 | 183 | 2,5 |
| F | 6716 TENEDOR POSTRE dessert fork, fourchette dessert, forchetta frutta, dessertgabel | 1/12/120/1440/7200 | 60 | 185 | 2,5 |
| G | 6717 TENEDOR LUNCH cake fork, fourchette gâteau, forchetta dolce, kuchengabel | 1/12/120/2520/15120 | 60 | 140 | 2,5 |
| H | 6718 CUCHARA CAFE tea spoon, cuillère café, cucchiaio caffè, kaffeelöffel | 1/12/120/2520/15120 | 60 | 140 | 2,5 |
| I | 6719 CUCHARA MOKA coffee/moka spoon, cuillère moka, cucchiaio moka, mokkalöffel | 1/12/120/2520/15120 | 60 | 110 | 2,5 |
| J | 7899 CUCHARA REFRESCO soda spoon, cuillère mazagran, cucchiaio bibita, longdrinklöffel | 1/12/120/1440/7200 | 60 | 202 | 2,5 |
| K | 7900 CUCHARA ENSALADA salad spoon, cuillère à servir salade, cucchiaio servire, salatlöffel | 1/10/50/800/4000 | 10 | 270 | 3 |
| L | 7901 TENEDOR ENSALADA salad fork, fourchette à servir salade, forchetta servire, salatgabel | 1/10/50/800/4000 | 10 | 265 | 3 |
| NEW | 5310 BLISTER 3 CUCHILLO MESA blister 3 table knife, blister 3 couteau table, blister 3 coltello tavola, blister 3 tafelmesser | 1/0/12/0/0 | 12 | | |
| NEW | 5312 BLISTER 6 CUCHARA MESA blister 6 table spoon, blister 6 cuillère table, blister 6 cucchiaio tavola, blister 6 tafellöffel | 1/0/12/0/0 | 12 | | |
| NEW | 5311 BLISTER 6 TENEDOR MESA blister 6 table fork, blister 6 fourchette table, blister 6 forchetta tavola, blister 6 tafelgabel | 1/0/12/0/0 | 12 | | |
| NEW | 1059 BLISTER 6 TENEDOR LUNCH blister 6 cake fork, blister 6 fourchette gâteau, blister 6 forchetta dolce, blister 6 kuchengabel | 1/0/12/0/0 | 12 | | |
| NEW | 5313 BLISTER 6 CUCHARA CAFE blister 6 tea spoon, blister 6 cuillère café, blister 6 cucchiaio caffè, blister 6 kaffeelöffel | 1/0/12/0/0 | 12 | | |
| NEW | 1060 BLISTER 6 CUCHARA MOKA blister 6 coffee/moka spoon, blister 6 cuillère moka, blister 6 cucchiaio moka, blister 6 mokkalöffel | 1/0/12/0/0 | 12 | | |
| 6720 | 24 PIEZAS 24 pieces, écriin 24 pièces, bauletto 24 pz., 24 stück | 1/0/4 | 4 | | 3 |

INOX
STAINLESS
STEEL
430

| | | UE | MOQ | ✂ mm | ✂ mm |
|-------------|---|---------------------|-----|------|------|
| A | 6102 CUCHILLO MESA table knife, couteau table, coltello tavola, tafelmesser | 1/12/120/1920/5760 | 60 | 221 | |
| B | 6103 CUCHARA MESA table spoon, cuillère table, cucchiaio tavola, tafellöffel | 1/12/120/1440/7200 | 60 | 200 | 3 |
| C | 6104 TENEDOR MESA table fork, fourchette table, forchetta tavola, tafelgabel | 1/12/120/1440/7200 | 60 | 200 | 3 |
| NEW | 11910 PALA PESCADO table fork, fourchette table, forchetta tavola, tafelgabel | 1/12/120/1440/7200 | 60 | 206 | 2,5 |
| NEW | 11911 TENEDOR PESCADO fish knife, couteau poisson, coltello pesce, fischmesser | 1/12/120/1440/7200 | 60 | 187 | 2,5 |
| F | 6353 CUCHILLO POSTRE dessert knife, couteau dessert, coltello frutta, dessertmesser | 1/12/120/1920/5760 | 60 | 202 | 2,5 |
| G | 6354 CUCHARA POSTRE dessert spoon, cuillère dessert, cucchiaio frutta, dessertlöffel | 1/12/120/1440/7200 | 60 | 183 | 2,5 |
| H | 6355 TENEDOR POSTRE dessert fork, fourchette dessert, forchetta frutta, dessertgabel | 1/12/120/1440/7200 | 60 | 185 | 2,5 |
| I | 6105 TENEDOR LUNCH cake fork, fourchette gâteau, forchetta dolce, kuchengabel | 1/12/120/2520/15120 | 60 | 140 | 2,5 |
| J | 6106 CUCHARA CAFÉ tea spoon, cuillère café, cucchiaio caffè, kaffeelöffel | 1/12/120/2520/15120 | 60 | 140 | 2,5 |
| K | 6107 CUCHARA MOKA coffee/moka spoon, cuillère moka, cucchiaio moka, mokkalöffel | 1/12/120/2520/15120 | 60 | 110 | 2,5 |
| L | 7552 CUCHARA REFRESCO soda spoon, cuillère mazagran, cucchiaio bibita, longdrinklöffel | 1/12/120/1440/7200 | 60 | 202 | 3 |
| O | 8798 CUCHARA APERITIVO appetizer spoon, cuillère apéritif, cucchiaio antipasto, aperitif löffel | 0/6/60/1440/4320 | 10 | 132 | 3 |
| M | 7963 CUCHARA ENSALADA salad spoon, cuillère à servir salade, cucchiaio servire, salatlöffel | 1/10/50/800/4000 | 10 | 270 | 3 |
| N | 7964 TENEDOR ENSALADA salad fork, fourchette à servir salade, forchetta servire, salatgabel | 1/10/50/800/4000 | 10 | 265 | 3 |
| NEW | 5318 BLISTER 3 CUCHILLO MESA blister 3 table knife, blister 3 couteau table, blister 3 coltello tavola, blister 3 tafelmesser | 1/0/12/0/0 | 12 | | |
| NEW | 5320 BLISTER 6 CUCHARA MESA blister 6 table spoon, blister 6 cuillère table, blister 6 cucchiaio tavola, blister 6 tafellöffel | 1/0/12/0/0 | 12 | | |
| NEW | 5319 BLISTER 6 TENEDOR MESA blister 6 table fork, blister 6 fourchette table, blister 6 forchetta tavola, blister 6 tafelgabel | 1/0/12/0/0 | 12 | | |
| NEW | 1061 BLISTER 6 TENEDOR LUNCH blister 6 cake fork, blister 6 fourchette gâteau, blister 6 forchetta dolce, blister 6 kuchengabel | 1/0/12/0/0 | 12 | | |
| NEW | 5321 BLISTER 6 CUCHARA CAFE blister 6 tea spoon, blister 6 cuillère café, blister 6 cucchiaio caffè, blister 6 kaffeelöffel | 1/0/12/0/0 | 12 | | |
| NEW | 1062 BLISTER 6 CUCHARA MOKA blister 6 coffee/moka spoon, blister 6 cuillère moka, blister 6 cucchiaio moka, blister 6 mokkalöffel | 1/0/12/0/0 | 12 | | |
| 6323 | 24 PIEZAS 24 pieces, écriin 24 pièces, bauletto 24 pz., 24 stück | 1/0/4 | 4 | | 3 |

Malvarrosa

INOX Nickel Free 18% / 4mm / Mirror

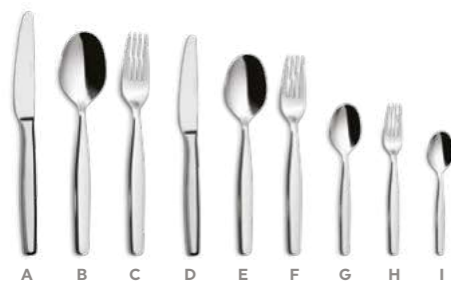

INOX
STAINLESS
STEEL
430

| | | | | | |
|---|--|---------------------|-----|-----|-----|
| A | 6573 CUCHILLO MESA table knife, couteau table, coltello tavola, tafelmesser | 0/12/120/1920/5760 | 120 | 225 | |
| B | 6574 CUCHARA MESA table spoon, cuillère table, cucchiaio tavola, tafellöffel | 0/12/120/1440/7200 | 120 | 206 | 4 |
| C | 6575 TENEDOR MESA table fork, fourchette table, forchetta tavola, tafelgabel | 0/12/120/1440/7200 | 120 | 206 | 4 |
| D | 6576 CUCHILLO POSTRE dessert knife, couteau dessert, coltello frutta, dessertmesser | 0/12/120/1440/7200 | 120 | 203 | |
| E | 6577 CUCHARA POSTRE dessert spoon, cuillère dessert, cucchiaio frutta, dessertlöffel | 0/12/120/1440/7200 | 120 | 185 | 3,5 |
| F | 6578 TENEDOR POSTRE dessert fork, fourchette dessert, forchetta frutta, dessertgabel | 0/12/120/1440/7200 | 120 | 185 | 3,5 |
| G | 6579 CUCHARA CAFÉ tea spoon, cuillère café, cucchiaio caffè, kaffeelöffel | 0/12/120/2520/15120 | 120 | 140 | 3 |
| H | 6580 TENEDOR LUNCH cake fork, fourchette gâteau, forchetta dolce, kuchengabel | 0/12/120/2520/15120 | 120 | 140 | 3 |
| I | 6581 CUCHARA MOKA coffee/moka spoon, cuillère moka, cucchiaio moka, mokkalöffel | 0/12/120/2520/15120 | 120 | 115 | 3 |
| | 6582 MAZO 2 CUCHILLO MESA film 2 table knife, film 2 couteau table, film 2 coltello tavola, film 2 tafelmesser | 1/0/48/1008/3024 | 48 | 225 | |
| | 6583 MAZO 3 CUCHARA MESA film 3 table spoon, film 3 cuillère table, film 3 cucchiaio tavola, film 3 tafellöffel | 1/0/48/1200/3600 | 48 | 206 | 4 |
| | 6584 MAZO 3 TENEDOR MESA film 3 table fork, film 3 fourchette table, film 3 forchetta tavola, film 3 tafelgabel | 1/0/48/1200/3600 | 48 | 206 | 4 |
| | 6585 MAZO 6 TENEDOR LUNCH film 6 cake fork, film 6 fourchette gâteau, film 6 forchetta dolce, film 6 kuchengabel | 1/0/48/1152/4608 | 48 | 140 | 3 |
| | 6586 MAZO 6 CUCHARA CAFÉ film 6 tea spoon, film 6 cuillère café, film 6 cucchiaio caffè, film 6 kaffeelöffel | 1/0/48/1152/4608 | 48 | 140 | 3 |
| | 6587 MAZO 6 CUCHARA MOKA film 6 coffee/moka spoon, film 6 cuillère moka, film 6 cucchiaio moka, film 6 mokkalöffel | 1/0/48/1152/4608 | 48 | 115 | 3 |
| | 6588 24 PIEZAS 24 pieces, écrin 24 pièces, bauletto 24 pz., 24 stück | 1/0/4 | 4 | | 4 |

120

Oslo Eco

INOX Nickel Free 18% / 7mm / Mirror / FORGED



INOX
STAINLESS
STEEL
430

NEW

| | | | | | |
|---|---|---------------------|-----|-----|-----|
| A | 5474 CUCHILLO MESA table knife, couteau table, coltello tavola, tafelmesser | 0/12/120/1920/5760 | 120 | 235 | |
| B | 1336 CUCHARA MESA table spoon, cuillère table, cucchiaio tavola, tafellöffel | 0/12/120/1440/7200 | 120 | 208 | 7 |
| C | 1337 TENEDOR MESA table fork, fourchette table, forchetta tavola, tafelgabel | 0/12/120/1440/7200 | 120 | 208 | 7 |
| D | 2568 TENEDOR LUNCH cake fork, fourchette gâteau, forchetta dolce, kuchengabel | 0/12/120/2520/15120 | 120 | 150 | 5,5 |
| E | 1338 CUCHARA CAFÉ tea spoon, cuillère café, cucchiaio caffè, kaffeelöffel | 0/12/120/2520/15120 | 120 | 145 | 5,5 |
| F | 2569 CUCHARA MOKA coffee/moka spoon, cuillère moka, cucchiaio moka, mokkalöffel | 0/12/120/2520/15120 | 120 | 120 | 4,5 |
| | 0298 24 PIEZAS 24 pieces, écrin 24 pièces, bauletto 24 pz., 24 stück | 1/0/4 | 4 | | 7 |

| UE | MOQ | ▶ mm | ✂ mm |
|---------------------|-----|------|------|
| 0/12/120/1920/5760 | 120 | 235 | |
| 0/12/120/1440/7200 | 120 | 208 | 7 |
| 0/12/120/1440/7200 | 120 | 208 | 7 |
| 0/12/120/2520/15120 | 120 | 150 | 5,5 |
| 0/12/120/2520/15120 | 120 | 145 | 5,5 |
| 0/12/120/2520/15120 | 120 | 120 | 4,5 |
| 1/0/4 | 4 | | 7 |

121

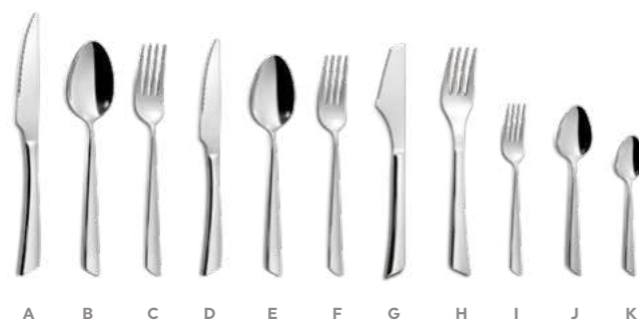

INOX
STAINLESS
STEEL
430

| | |
|---|---|
| A | 3197 CUCHILLO CHULETERO steak knife, couteau steak, coltello bistecca, steakmesser |
| B | 3198 CUCHARA MESA table spoon, cuillère table, cucchiaio tavola, tafellöffel |
| C | 3199 TENEDOR MESA table fork, fourchette table, forchetta tavola, tafelgabel |
| D | 3200 CUCHILLO POSTRE dessert knife, couteau dessert, coltello frutta, dessertmesser |
| E | 3201 CUCHARA POSTRE dessert spoon, cuillère dessert, cucchiaio frutta, dessertlöffel |
| F | 3202 TENEDOR POSTRE dessert fork, fourchette dessert, forchetta frutta, dessertgabel |
| G | 3263 CUCHILLO PIZZA pizza knife, couteau pizza, coltello pizza, pizza tafelmesser |
| H | 3264 TENEDOR PIZZA pizza fork, fourchette pizza, forchetta pizza, pizza gabel |
| I | 3203 TENEDOR LUNCH cake fork, fourchette gâteau, forchetta dolce, kuchengabel |
| J | 3204 CUCHARA CAFÉ tea spoon, cuillère café, cucchiaio caffè, kaffeelöffel |
| K | 3205 CUCHARA MOKA coffee/moka spoon, cuillère moka, cucchiaio moka, mokkalöffel |
| | 3216 MAZO 2 CUCHILLO CHULETERO film 2 steak knife, film 2 couteau steak, film 2 coltello bistecca, film 2 steakmesser |
| | 3217 MAZO 3 CUCHARA MESA film 3 table spoon, film 3 cuillère table, film 3 cucchiaio tavola, film 3 tafellöffel |
| | 3218 MAZO 3 TENEDOR MESA film 3 table fork, film 3 fourchette table, film 3 forchetta tavola, film 3 tafelgabel |
| | 3219 MAZO 2 CUCHILLO POSTRE film 2 dessert knife, film 2 couteau dessert, film 2 coltello frutta, film 2 dessertmesser |
| | 3220 MAZO 3 CUCHARA POSTRE film 3 dessert spoon, film 3 cuillère dessert, film 3 cucchiaio frutta, film 3 dessertlöffel |
| | 3221 MAZO 3 TENEDOR POSTRE film 3 dessert fork, film 3 fourchette dessert, film 3 forchetta frutta, film 3 dessertgabel |
| | 3222 MAZO 6 TENEDOR LUNCH film 6 cake fork, film 6 fourchette gâteau, film 6 forchetta dolce, film 6 kuchengabel |
| | 3223 MAZO 6 CUCHARA CAFÉ film 6 tea spoon, film 6 cuillère café, film 6 cucchiaio caffè, film 6 kaffeelöffel |
| | 3224 MAZO 6 CUCHARA MOKA film 6 coffee/moka spoon, film 6 cuillère moka, film 6 cucchiaio moka, film 6 mokkalöffel |



| UE | MOQ | ▶ mm | ✕ mm |
|---------------------|-----|------|------|
| 0/12/120/1920/5760 | 120 | 233 | |
| 0/12/120/1440/7200 | 120 | 208 | 4 |
| 0/12/120/1440/7200 | 120 | 208 | 4 |
| 0/12/120/1920/5760 | 120 | 210 | |
| 0/12/120/1440/7200 | 120 | 195 | 4 |
| 0/12/120/1440/7200 | 120 | 195 | 4 |
| 0/12/120/1920/5760 | 120 | 205 | |
| 0/12/120/1920/5760 | 120 | 202 | 4 |
| 0/12/120/2520/15120 | 120 | 152 | 3 |
| 0/12/120/2520/15120 | 120 | 150 | 3 |
| 0/12/120/2520/15120 | 120 | 125 | 3 |
| 1/0/48/1008/3024 | 48 | 233 | |
| 1/0/48/1200/3600 | 48 | 208 | 4 |
| 1/0/48/1200/3600 | 48 | 208 | 4 |
| 1/0/48/1008/3024 | 48 | 210 | |
| 1/0/48/1200/3600 | 48 | 195 | 4 |
| 1/0/48/1200/3600 | 48 | 195 | 4 |
| 1/0/48/1152/4608 | 48 | 152 | 3 |
| 1/0/48/1152/4608 | 48 | 150 | 3 |
| 1/0/48/1152/4608 | 48 | 125 | 3 |



3227 24 PIEZAS
24 pieces. écrin 24 pièces. bauletto 24 pz., 24 stück

| UE | MOQ | ▶ mm | ✕ mm |
|-------|-----|------|------|
| 1/0/4 | 4 | | 4 |





INOX Nickel Free 18% / 4mm / Mirror



INOX
STAINLESS
STEEL
430

- A **6537** CUCHILLO MESA XL
XL table knife, couteau table XL, coltello tavola XL, XL tafelmesser
- B **6538** CUCHARA MESA XL
XL table spoon, cuillère table XL, cucchiaio tavola XL, XL tafellöffel
- C **6539** TENEDOR MESA XL
XL table fork, fourchette table XL, forchetta tavola XL, XL tafelgabel
- D **6546** CUCHARA CAFÉ XL
XL coffee spoon, cuillère café XL, cucchiaio caffè XL, XL kaffeeöffel
- E **6540** CUCHILLO MESA
table knife, couteau table, coltello tavola, tafelmesser
- F **6541** CUCHARA MESA
table spoon, cuillère table, cucchiaio tavola, tafellöffel
- G **6542** TENEDOR MESA
table fork, fourchette table, forchetta tavola, tafelgabel
- H **6543** CUCHILLO POSTRE
dessert knife, couteau dessert, coltello frutta, dessertmesser
- I **6544** CUCHARA POSTRE
dessert spoon, cuillère dessert, cucchiaio frutta, dessertlöffel
- J **6545** TENEDOR POSTRE
dessert fork, fourchette dessert, forchetta frutta, dessertgabel
- K **6547** CUCHARA CAFÉ
tea spoon, cuillère café, cucchiaio caffè, kaffeeöffel
- L **6548** TENEDOR LUNCH
cake fork, fourchette gâteau, forchetta dolce, kuchengabel
- M **6549** CUCHARA MOKA
coffee/moka spoon, cuillère moka, cucchiaio moka, mokkalöffel
- 6550** MAZO 2 CUCHILLO MESA
film 2 table knife, film 2 couteau table, film 2 coltello tavola, film 2 tafelmesser
- 6551** MAZO 3 CUCHARA MESA
film 3 table spoon, film 3 cuillère table, film 3 cucchiaio tavola, film 3 tafellöffel
- 6552** MAZO 3 TENEDOR MESA
film 3 table fork, film 3 fourchette table, film 3 forchetta tavola, film 3 tafelgabel
- 6553** MAZO 6 TENEDOR LUNCH
film 6 cake fork, film 6 fourchette gâteau, film 6 forchetta dolce, film 6 kuchengabel
- 6554** MAZO 6 CUCHARA CAFÉ
film 6 tea spoon, film 6 cuillère café, film 6 cucchiaio caffè, film 6 kaffeeöffel
- 6555** MAZO 6 CUCHARA MOKA
film 6 coffee/moka spoon, film 6 cuillère moka, film 6 cucchiaio moka, film 6 mokkalöffel
- 6556** 24 PIEZAS
24 pieces, écrien 24 pièces, bauletto 24 pz., 24 stück

| UE | MOQ | ✂ mm | ✂ mm |
|---------------------|-----|------|------|
| 0/12/120/1920/5760 | 120 | 250 | |
| 0/12/120/1440/7200 | 120 | 230 | 4 |
| 0/12/120/1440/7200 | 120 | 228 | 4 |
| 0/12/120/2520/15120 | 120 | 162 | 3 |
| 0/12/120/1920/5760 | 120 | 233 | |
| 0/12/120/1440/7200 | 120 | 206 | 4 |
| 0/12/120/1440/7200 | 120 | 204 | 4 |
| 0/12/120/1920/5760 | 120 | 209 | |
| 0/12/120/1440/7200 | 120 | 185 | 3 |
| 0/12/120/1440/7200 | 120 | 184 | 3 |
| 0/12/120/2520/15120 | 120 | 145 | 3 |
| 0/12/120/2520/15120 | 120 | 150 | 3 |
| 0/12/120/2520/15120 | 120 | 115 | 2 |
| 1/0/48/1008/3024 | 48 | 233 | |
| 1/0/48/1200/3600 | 48 | 206 | 4 |
| 1/0/48/1200/3600 | 48 | 204 | 4 |
| 1/0/48/1152/4608 | 48 | 150 | 3 |
| 1/0/48/1152/4608 | 48 | 145 | 3 |
| 1/0/48/1152/4608 | 48 | 115 | 2 |
| 1/0/4 | 4 | | 3 |



Canada Vintage

INOX Nickel Free 18% / 4mm / Vintage

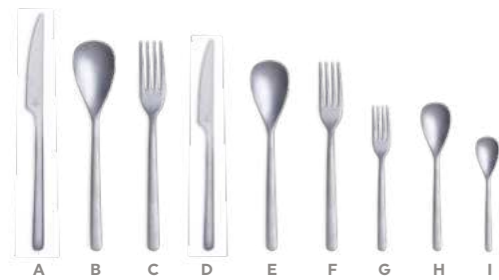

Canada Vintage Gold

INOX Nickel Free 18% / 4mm / Vintage



INOX
STAINLESS
STEEL
430

- A **1241** CUCHILLO MESA
table knife, couteau table, coltello tavola, tafelmesser
- B **1242** CUCHARA MESA
table spoon, cuillère table, cucchiaio tavola, tafellöffel
- C **1243** TENEDOR MESA
table fork, fourchette table, forchetta tavola, tafelgabel
- D **1244** CUCHILLO POSTRE
dessert knife, couteau dessert, coltello frutta, dessertmesser
- E **1245** CUCHARA POSTRE
dessert spoon, cuillère dessert, cucchiaio frutta, dessertlöffel
- F **1246** TENEDOR POSTRE
dessert fork, fourchette dessert, forchetta frutta, dessertgabel
- G **1247** TENEDOR LUNCH
cake fork, fourchette gâteau, forchetta dolce, kuchengabel
- H **1248** CUCHARA CAFÉ
tea spoon, cuillère café, cucchiaio caffè, kaffeelöffel
- I **1249** CUCHARA MOKA
coffee/moka spoon, cuillère moka, cucchiaio moka, mokkalöffel

1228 24 PIEZAS
24 pieces, écrin 24 pièces, bauletto 24 pz., 24 stück

| UE | MOQ | ▶ mm | ✂ mm |
|---------------------|-----|------|------|
| 0/12/120/1920/5760 | 60 | 233 | |
| 0/12/120/1440/7200 | 60 | 206 | 4 |
| 0/12/120/1440/7200 | 60 | 204 | 4 |
| 0/12/120/1920/5760 | 60 | 209 | |
| 0/12/120/1440/7200 | 60 | 185 | 3 |
| 0/12/120/1440/7200 | 60 | 184 | 3 |
| 0/12/120/2520/15120 | 60 | 145 | 3 |
| 0/12/120/2520/15120 | 60 | 150 | 3 |
| 0/12/120/2520/15120 | 60 | 115 | 2 |
| 1/0/4 | 4 | | 4 |



INOX
STAINLESS
STEEL
430

- A **1252** CUCHILLO MESA
table knife, couteau table, coltello tavola, tafelmesser
- B **1253** CUCHARA MESA
table spoon, cuillère table, cucchiaio tavola, tafellöffel
- C **1254** TENEDOR MESA
table fork, fourchette table, forchetta tavola, tafelgabel
- D **1255** CUCHILLO POSTRE
dessert knife, couteau dessert, coltello frutta, dessertmesser
- E **1256** CUCHARA POSTRE
dessert spoon, cuillère dessert, cucchiaio frutta, dessertlöffel
- F **1257** TENEDOR POSTRE
dessert fork, fourchette dessert, forchetta frutta, dessertgabel
- G **1258** TENEDOR LUNCH
cake fork, fourchette gâteau, forchetta dolce, kuchengabel
- H **1259** CUCHARA CAFÉ
tea spoon, cuillère café, cucchiaio caffè, kaffeelöffel
- I **1260** CUCHARA MOKA
coffee/moka spoon, cuillère moka, cucchiaio moka, mokkalöffel

1229 24 PIEZAS
24 pieces, écrin 24 pièces, bauletto 24 pz., 24 stück

| UE | MOQ | ▶ mm | ✂ mm |
|---------------------|-----|------|------|
| 0/12/120/1920/5760 | 60 | 233 | |
| 0/12/120/1440/7200 | 60 | 206 | 4 |
| 0/12/120/1440/7200 | 60 | 204 | 4 |
| 0/12/120/1920/5760 | 60 | 209 | |
| 0/12/120/1440/7200 | 60 | 185 | 3 |
| 0/12/120/1440/7200 | 60 | 184 | 3 |
| 0/12/120/2520/15120 | 60 | 145 | 3 |
| 0/12/120/2520/15120 | 60 | 150 | 3 |
| 0/12/120/2520/15120 | 60 | 115 | 2 |
| 1/0/4 | 4 | | 4 |



Canada Vintage Champagne

INOX Nickel Free 18% / 4mm / Vintage



Canada Polvo de Luna

INOX Nickel Free 18% / 4mm / Shotblasting

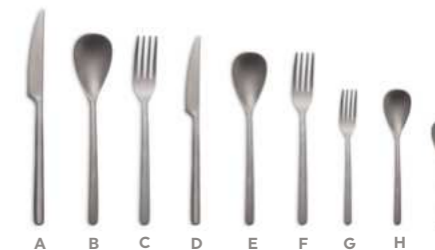

- A **11645** CUCHILLO MESA
table knife, couteau table, coltello tavola, tafelmesser
- B **11646** CUCHARA MESA
table spoon, cuillère table, cucchiaio tavola, tafellöffel
- C **11647** TENEDOR MESA
table fork, fourchette table, forchetta tavola, tafelgabel
- D **11648** CUCHILLO POSTRE
dessert knife, couteau dessert, coltello frutta, dessertmesser
- E **11649** CUCHARA POSTRE
dessert spoon, cuillère dessert, cucchiaio frutta, dessertlöffel
- F **11650** TENEDOR POSTRE
dessert fork, fourchette dessert, forchetta frutta, dessertgabel
- G **11651** TENEDOR LUNCH
cake fork, fourchette gâteau, forchetta dolce, kuchengabel
- H **11652** CUCHARA CAFÉ
tea spoon, cuillère café, cucchiaio caffè, kaffeelöffel
- I **11653** CUCHARA MOKA
coffee/moka spoon, cuillère moka, cucchiaio moka, mokkalöffel

| UE | MOQ | mm | mm |
|---------------------|-----|-----|----|
| 0/12/120/1920/5760 | 60 | 233 | |
| 0/12/120/1440/7200 | 60 | 206 | 4 |
| 0/12/120/1440/7200 | 60 | 204 | 4 |
| 0/12/120/1920/5760 | 60 | 209 | |
| 0/12/120/1440/7200 | 60 | 185 | 3 |
| 0/12/120/1440/7200 | 60 | 184 | 3 |
| 0/12/120/2520/15120 | 60 | 145 | 3 |
| 0/12/120/2520/15120 | 60 | 150 | 3 |
| 0/12/120/2520/15120 | 60 | 115 | 2 |

11654 24 PIEZAS
24 pieces, écrin 24 pièces, bauletto 24 pz., 24 stück



- A **5073** CUCHILLO MESA
table knife, couteau table, coltello tavola, tafelmesser
- B **5074** CUCHARA MESA
table spoon, cuillère table, cucchiaio tavola, tafellöffel
- C **5075** TENEDOR MESA
table fork, fourchette table, forchetta tavola, tafelgabel
- D **5076** CUCHILLO POSTRE
dessert knife, couteau dessert, coltello frutta, dessertmesser
- E **5077** CUCHARA POSTRE
dessert spoon, cuillère dessert, cucchiaio frutta, dessertlöffel
- F **5078** TENEDOR POSTRE
dessert fork, fourchette dessert, forchetta frutta, dessertgabel
- G **5079** TENEDOR LUNCH
cake fork, fourchette gâteau, forchetta dolce, kuchengabel
- H **5080** CUCHARA CAFÉ
tea spoon, cuillère café, cucchiaio caffè, kaffeelöffel
- I **5081** CUCHARA MOKA
coffee/moka spoon, cuillère moka, cucchiaio moka, mokkalöffel

| UE | MOQ | mm | mm |
|---------------------|-----|-----|----|
| 0/12/120/1920/5760 | 120 | 233 | |
| 0/12/120/1440/7200 | 120 | 206 | 4 |
| 0/12/120/1440/7200 | 120 | 204 | 4 |
| 0/12/120/1920/5760 | 120 | 209 | |
| 0/12/120/1440/7200 | 120 | 185 | 3 |
| 0/12/120/1440/7200 | 120 | 184 | 3 |
| 0/12/120/2520/15120 | 120 | 145 | 3 |
| 0/12/120/2520/15120 | 120 | 150 | 3 |
| 0/12/120/2520/15120 | 120 | 115 | 2 |

5083 24 PIEZAS
24 pieces, écrin 24 pièces, bauletto 24 pz., 24 stück



Canada Vintage Copper

INOX Nickel Free 18% / 4mm / Vintage



Canada Vintage Black

INOX Nickel Free 18% / 4mm / Vintage



INOX
STAINLESS
STEEL
430

| | | |
|---|-------------|--|
| A | 1270 | CUCHILLO MESA table knife, couteau table, coltello tavola, tafelmesser |
| B | 1271 | CUCHARA MESA table spoon, cuillère table, cucchiaio tavola, tafellöffel |
| C | 1272 | TENEDOR MESA table fork, fourchette table, forchetta tavola, tafelgabel |
| D | 1273 | CUCHILLO POSTRE dessert knife, couteau dessert, coltello frutta, dessertmesser |
| E | 1274 | CUCHARA POSTRE dessert spoon, cuillère dessert, cucchiaio frutta, dessertlöffel |
| F | 1275 | TENEDOR POSTRE dessert fork, fourchette dessert, forchetta frutta, dessertgabel |
| G | 1276 | TENEDOR LUNCH cake fork, fourchette gâteau, forchetta dolce, kuchengabel |
| H | 1277 | CUCHARA CAFÉ tea spoon, cuillère café, cucchiaio caffè, kaffeelöffel |
| I | 1278 | CUCHARA MOKA coffee/moka spoon, cuillère moka, cucchiaio moka, mokkalöffel |

| UE | MOQ | ▶ mm | ✂ mm |
|---------------------|-----|------|------|
| 0/12/120/1920/5760 | 60 | 233 | |
| 0/12/120/1440/7200 | 60 | 206 | 4 |
| 0/12/120/1440/7200 | 60 | 204 | 4 |
| 0/12/120/1920/5760 | 60 | 209 | |
| 0/12/120/1440/7200 | 60 | 185 | 3 |
| 0/12/120/1440/7200 | 60 | 184 | 3 |
| 0/12/120/2520/15120 | 60 | 145 | 3 |
| 0/12/120/2520/15120 | 60 | 150 | 3 |
| 0/12/120/2520/15120 | 60 | 115 | 2 |



INOX
STAINLESS
STEEL
430

| | | |
|---|-------------|--|
| A | 1261 | CUCHILLO MESA table knife, couteau table, coltello tavola, tafelmesser |
| B | 1262 | CUCHARA MESA table spoon, cuillère table, cucchiaio tavola, tafellöffel |
| C | 1263 | TENEDOR MESA table fork, fourchette table, forchetta tavola, tafelgabel |
| D | 1264 | CUCHILLO POSTRE dessert knife, couteau dessert, coltello frutta, dessertmesser |
| E | 1265 | CUCHARA POSTRE dessert spoon, cuillère dessert, cucchiaio frutta, dessertlöffel |
| F | 1266 | TENEDOR POSTRE dessert fork, fourchette dessert, forchetta frutta, dessertgabel |
| G | 1267 | TENEDOR LUNCH cake fork, fourchette gâteau, forchetta dolce, kuchengabel |
| H | 1268 | CUCHARA CAFÉ tea spoon, cuillère café, cucchiaio caffè, kaffeelöffel |
| I | 1269 | CUCHARA MOKA coffee/moka spoon, cuillère moka, cucchiaio moka, mokkalöffel |

| UE | MOQ | ▶ mm | ✂ mm |
|---------------------|-----|------|------|
| 0/12/120/1920/5760 | 60 | 233 | |
| 0/12/120/1440/7200 | 60 | 206 | 4 |
| 0/12/120/1440/7200 | 60 | 204 | 4 |
| 0/12/120/1920/5760 | 60 | 209 | |
| 0/12/120/1440/7200 | 60 | 185 | 3 |
| 0/12/120/1440/7200 | 60 | 184 | 3 |
| 0/12/120/2520/15120 | 60 | 145 | 3 |
| 0/12/120/2520/15120 | 60 | 150 | 3 |
| 0/12/120/2520/15120 | 60 | 115 | 2 |



Finger Food



INOX Nickel Free 18% / 2mm / Mirror



A B C D

Finger Food

INOX Nickel Free 18% / 2mm / Vintage



MINI CUBIERTOS PARA EXPERIENCIAS DE GRAN SABOR
MINI CUTLERY FOR GREAT TASTING EXPERIENCES



Cubertería de diseño propio creada para comidas de servicio rápido.
Cutlery of our own design created for quick service meals.

INOX
STAINLESS
STEEL
430

- A **8784** CUCHILLO LUNCH
cake knife, couteau gâteau, coltello dolce, kuchenmesser
- B **8786** CUCHARA CAFÉ
tea spoon, cuillère café, cucchiaio caffè, kaffeeelöffel
- C **8785** TENEDOR LUNCH
cake fork, fourchette gâteau, forchetta dolce, kuchengabel
- D **8787** PINCHO TAPAS
cocktail stick, stick à cocktail, spiedo, spieb
- 8795** PACK 4 PCS
pack 4 pieces, pack 4 pièces, pack 4 pz., 4 pack

| UE | MOQ | ▶ mm | ✂ mm |
|---------------------|-----|------|------|
| 0/12/120/2520/15120 | 24 | 140 | 6 |
| 0/12/120/2520/15120 | 24 | 130 | 2 |
| 0/12/120/2520/15120 | 24 | 130 | 2 |
| 0/12/120/2520/15120 | 24 | 137 | 2 |
| 1/24/96/576/2880 | 24 | | 2 |



INOX
STAINLESS
STEEL
430



1001 Black

INOX Nickel Free 18% / 1,5mm / PVD

- A **1746** TENEDOR MINI LUNCH
mini cake fork, fourchette minigâteau, forchetta mini dolce, kuchengabel klein
- B **1747** CUCHARA MOKA
coffee/moka spoon, cuillère moka, cucchiaio moka, mokkalöffel

| UE | MOQ | ▶ mm | ✂ mm |
|----------------------|-----|------|------|
| 0/12/600/25200/75600 | 120 | 110 | 1 |
| 0/12/600/25200/75600 | 120 | 110 | 1 |



Santorini



INOX Nickel Free 18% / 3,5mm / Mirror



Santorini

INOX Nickel Free 18% / 3,5mm / Mirror

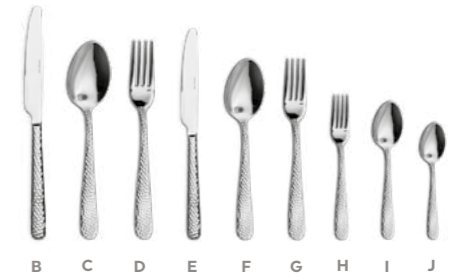

INOX
STAINLESS
STEEL
430

- A **11584** CUCHILLO CHULETERO
steak knife, couteau steak, coltello bistecca, steakmesser
- B **10642** CUCHILLO MESA
table knife, couteau table, coltello tavola, tafelmesser
- C **10643** CUCHARA MESA
table spoon, cuillère table, cucchiaio tavola, tafellöffel
- D **10644** TENEDOR MESA
table fork, fourchette table, forchetta tavola, tafelgabel
- E **10832** CUCHILLO POSTRE
dessert knife, couteau dessert, coltello frutta, dessertmesser
- F **10833** CUCHARA POSTRE
dessert spoon, cuillère dessert, cucchiaio frutta, dessertlöffel
- G **10834** TENEDOR POSTRE
dessert fork, fourchette dessert, forchetta frutta, dessertgabel
- H **10645** TENEDOR LUNCH
cake fork, fourchette gâteau, forchetta dolce, kuchengabel
- I **10646** CUCHARA CAFÉ
tea spoon, cuillère café, cucchiaio caffè, kaffeelöffel
- J **10647** CUCHARA MOKA
coffee/moka spoon, cuillère moka, cucchiaio moka, mokkalöffe
- B **10928** MAZO 2 CUCHILLO MESA
film 2 table knife, film 2 couteau table, film 2 coltello tavola, film 2 tafelmesser
- C **10929** MAZO 3 CUCHARA MESA
film 3 table spoon, film 3 cuillère table, film 3 cucchiaio tavola, film 3 löffel
- G **10930** MAZO 3 TENEDOR MESA
film 3 table fork, film 3 fourchette table, film 3 forchetta tavola, film 3 tafelgabel
- H **10931** MAZO 6 TENEDOR LUNCH
film 6 cake fork, film 6 fourchette gâteau, film 6 forchetta dolce, film 6 kuchengabel
- I **10932** MAZO 6 CUCHARA CAFÉ
film 6 tea spoon, film 6 cuillère café, film 6 cucchiaio caffè, film 6 kaffeelöffel
- J **10933** MAZO 6 CUCHARA MOKA
film 6 coffee/moka spoon, film 6 cuillère moka, film 6 cucchiaio moka, film 6 mokkalöffe

- 5187** 24 PIEZAS
24 pieces, écrin 24 pièces, bauletto 24 pz., 24 stück

| UE | MOQ | ▶ mm | ✕ mm |
|--------------------|-----|------|------|
| 1/12/120/1920/5760 | 120 | 232 | |
| 0//120/1920/5760 | 120 | 235 | |
| 0//120/1440/7200 | 120 | 200 | 3,5 |
| 0//120/1440/7200 | 120 | 200 | 3,5 |
| 0/12/120/1920/5760 | 120 | 210 | |
| 0/12/120/1440/7200 | 120 | 180 | |
| 0/12/120/1440/7200 | 120 | 180 | |
| 0//120/2520/15120 | 120 | 148 | 2 |
| 0//120/2520/15120 | 120 | 140 | 2 |
| 0//120/2520/15120 | 120 | 116 | 2 |
| 1/0/48/1008/3024 | 48 | 235 | |
| 1/0/48/1200/3600 | 48 | 200 | |
| 1/0/48/1200/3600 | 48 | 200 | |
| 1/0/48/1152/4608 | 48 | 148 | |
| 1/0/48/1152/4608 | 48 | 148 | |
| 1/0/48/1152/4608 | 48 | 116 | |
| 1/0/4 | 4 | | |



Chef Free

INOX Nickel Free 18% / 3,5mm / Mirror

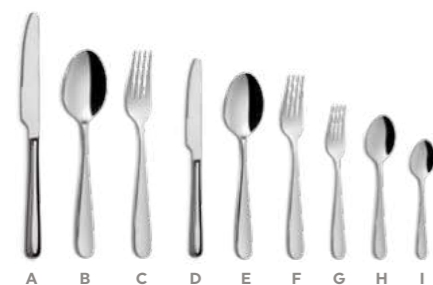

Lotus Free

INOX Nickel Free 18% / 3,5mm / Mirror



INOX
STAINLESS
STEEL
430

| | | |
|---|--------------|--|
| A | 5033 | CUCHILLO MESA table knife, couteau table, coltello tavola, tafelmesser |
| B | 9626 | CUCHARA MESA table spoon, cuillère table, cucchiaio tavola, tafellöffel |
| C | 9627 | TENEDOR MESA table fork, fourchette table, forchetta tavola, tafelgabel |
| D | 5034 | CUCHILLO POSTRE dessert knife, couteau dessert, coltello frutta, dessertmesser |
| E | 10835 | CUCHARA POSTRE dessert spoon, cuillère dessert, cucchiaio frutta, dessertlöffel |
| F | 10836 | TENEDOR POSTRE dessert fork, fourchette dessert, forchetta frutta, dessertgabel |
| G | 10837 | TENEDOR LUNCH cake fork, fourchette gâteau, forchetta dolce, kuchengabel |
| H | 9628 | CUCHARA CAFÉ tea spoon, cuillère café, cucchiaio caffè, kaffeelöffel |
| I | 10838 | CUCHARA MOKA coffee/moka spoon, cuillère moka, cucchiaio moka, mokkalöffel |

INOX
STAINLESS
STEEL
430

| | | |
|---|-------------|--|
| A | 3139 | CUCHILLO MESA table knife, couteau table, coltello tavola, tafelmesser |
| B | 9629 | CUCHARA MESA table spoon, cuillère table, cucchiaio tavola, tafellöffel |
| C | 9630 | TENEDOR MESA table fork, fourchette table, forchetta tavola, tafelgabel |
| D | 3145 | CUCHILLO POSTRE dessert knife, couteau dessert, coltello frutta, dessertmesser |
| E | 5255 | CUCHARA POSTRE dessert spoon, cuillère dessert, cucchiaio frutta, dessertlöffel |
| F | 5256 | TENEDOR POSTRE dessert fork, fourchette dessert, forchetta frutta, dessertgabel |
| G | 5257 | TENEDOR LUNCH cake fork, fourchette gâteau, forchetta dolce, kuchengabel |
| H | 9631 | CUCHARA CAFÉ tea spoon, cuillère café, cucchiaio caffè, kaffeelöffel |
| I | 5258 | CUCHARA MOKA coffee/moka spoon, cuillère moka, cucchiaio moka, mokkalöffel |

| UE | MOQ | ▶ mm | ✂ mm |
|---------------------|-----|------|------|
| 0/12/120/1920/5760 | 60 | 225 | |
| 0/12/120/1440/7200 | 120 | 211 | 3,5 |
| 0/12/120/1440/7200 | 120 | 211 | 3,5 |
| 0/12/120/1920/5760 | 60 | 195 | |
| 0/12/120/1440/7200 | 120 | 188 | 3,5 |
| 0/12/120/1440/7200 | 120 | 186 | 3,5 |
| 0/12/120/2520/15120 | 120 | 147 | 3,5 |
| 0/12/120/2520/15120 | 120 | 139 | 3,5 |
| 0/12/120/2520/15120 | 120 | 114 | |

Kyoto

INOX 18/10 / 5,5mm / Mirror / Satin

Cheese

INOX Nickel Free 18% / 3mm / Mirror

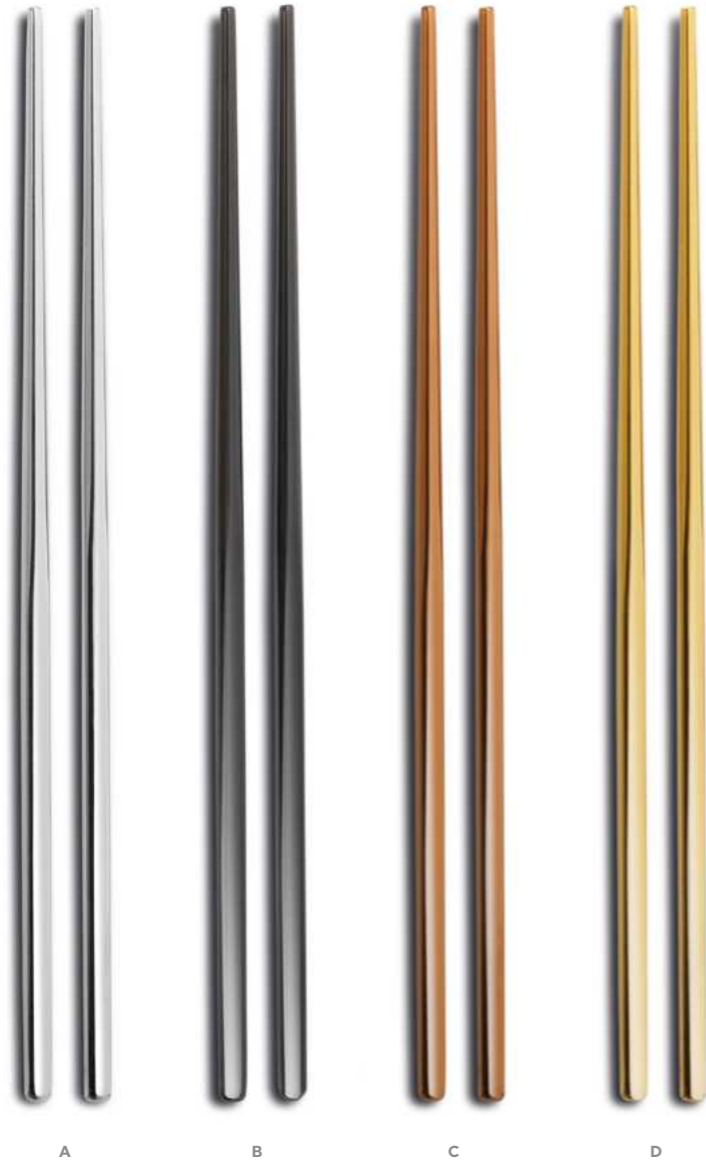

Mango hueco para una manipulación más ligera.
Hollow handle for lighter handling.



INOX STAINLESS STEEL 304

- A **7421** SET PALILLOS INOX
chopsticks set 18/10, set baguettes 18/10, set baguettes 18/10, essstäbchen set 18/10
- B **7422** SET PALILLOS BLACK
chopsticks set black 18/10, set baguettes black 18/10, set baguettes black 18/10, essstäbchen set 18/10 black
- C **7423** SET PALILLOS COPPER
chopsticks set copper 18/10, set baguettes copper 18/10, set baguettes copper 18/10, essstäbchen set 18/10 copper
- D **7424** SET PALILLOS GOLD
chopsticks set gold 18/10, set baguettes gold 18/10, set baguettes gold 18/10, essstäbchen set 18/10 gold
- E **7554** REPOSA PALILLOS BLOQUE SATIN
chopsticks rest satin 18/10, porte baguette satin 18/10, supporto posate satin 18/10, besteckhalter satin 18/10
- F **7555** REPOSA PALILLOS BLOQUE NEGRO
chopsticks rest black 18/10, porte baguette black 18/10, supporto posate black 18/10, besteckhalter black 18/10

| UE | MOQ | ✂ mm | ✂ mm |
|--------------------|-----|------|------|
| 0/12/120/1920/5760 | 12 | 230 | 11 |
| 0/12/120/1920/5760 | 12 | 230 | 11 |
| 0/12/120/1920/5760 | 12 | 230 | 11 |
| 0/12/120/1920/5760 | 12 | 230 | 11 |
| 0/12/120/1920/5760 | 12 | 60 | 11 |
| 0/12/120/1920/5760 | 12 | 60 | |

INOX STAINLESS STEEL 430

- A **5610** CUCHILLO CHULETERO
steak knife, couteau steak, coltello bistecca, steakmesser
- B **5611** CUCHARA MESA
table spoon, cuillère table, cucchiaio tavola, tafellöffel
- C **5612** TENEDOR MESA
table fork, fourchette table, forchetta tavola, tafelgabel
- D **5615** CUCHILLO POSTRE
dessert knife, couteau dessert, coltello frutta, dessertmesser
- E **5613** CUCHARA POSTRE
dessert spoon, cuillère dessert, cucchiaio frutta, dessertlöffel
- F **5614** TENEDOR POSTRE
dessert fork, fourchette dessert, forchetta frutta, dessertgabel
- G **5593** CUCHARA CAFÉ
tea spoon, cuillère café, cucchiaio caffè, kaffeelöffel
- H **5595** TENEDOR LUNCH
cake fork, fourchette gâteau, forchetta dolce, kuchengabel
- I **5594** CUCHARA MOKA
coffee/moka spoon, cuillère moka, cucchiaio moka, mokkalöffel

- 5616** MAZO 2 CUCHILLO CHULETERO
film 2 steak knife, film 2 couteau steak, film 2 coltello bistecca, film 2 steakmesser
- 5617** MAZO 3 CUCHARA MESA
film 3 table spoon, film 3 cuillère table, film 3 cucchiaio tavola, film 3 löffel
- 5618** MAZO 3 TENEDOR MESA
film 3 table fork, film 3 fourchette table, film 3 forchetta tavola, film 3 tafelgabel
- 5619** MAZO 6 TENEDOR LUNCH
film 6 cake fork, film 6 fourchette gâteau, film 6 forchetta dolce, film 6 kuchengabel
- 5620** MAZO 6 CUCHARA CAFÉ
film 6 tea spoon, film 6 cuillère café, film 6 cucchiaio caffè, film 6 kaffeelöffel
- 5621** MAZO 6 CUCHARA MOKA
film 6 coffee/moka spoon, film 6 cuillère moka, film 6 cucchiaio moka, film 6 mokkalöffel

- 2894** 24 PIEZAS
24 pieces, écrin 24 pièces, bauletto 24 pz., 24 stück

| UE | MOQ | ✂ mm | ✂ mm |
|---------------------|-----|------|------|
| 0/12/120/1920/5760 | 120 | 225 | 7 |
| 0/12/120/1440/7200 | 120 | 200 | 3 |
| 0/12/120/1440/7200 | 120 | 200 | 3 |
| 0/12/120/1920/5760 | 120 | 200 | |
| 0/12/120/1440/7200 | 120 | 184 | 2 |
| 0/12/120/1440/7200 | 120 | 184 | 2 |
| 0/12/120/2520/15120 | 120 | 142 | 2 |
| 0/12/120/2520/15120 | 120 | 145 | 2 |
| 0/12/120/2520/15120 | 120 | 110 | 1,8 |
| 1/0/48/1008/3024 | 48 | 225 | |
| 1/0/48/1200/3600 | 48 | 200 | 3 |
| 1/0/48/1200/3600 | 48 | 200 | 3 |
| 1/0/48/1152/4608 | 48 | 145 | 2 |
| 1/0/48/1152/4608 | 48 | 142 | 2 |
| 1/0/48/1152/4608 | 48 | 110 | 1,8 |
| 1/0/4 | 4 | | 2,5 |

Hidraulic

INOX Nickel Free 18% / 3mm / Mirror



Hidraulic Black

INOX Nickel Free 18% / 3mm / Mirror



INOX
STAINLESS
STEEL
430

| | | | | | | |
|---|-------------|---|---------------------|-----|-----|---|
| A | 6464 | CUCHILLO CHULETERO steak knife, couteau steak, coltello bistecca, steakmesser | 0/12/120/1920/5760 | 120 | 220 | |
| B | 6326 | CUCHILLO MESA table knife, couteau table, coltello tavola, tafelmesser | 0/12/120/1920/5760 | 120 | 220 | |
| C | 6327 | CUCHARA MESA table spoon, cuillère table, cucchiaio tavola, tafellöffel | 0/12/120/1440/7200 | 120 | 200 | 3 |
| D | 6328 | TENEDOR MESA table fork, fourchette table, forchetta tavola, tafelgabel | 0/12/120/1440/7200 | 120 | 200 | 3 |
| E | 6329 | TENEDOR LUNCH cake fork, fourchette gâteau, forchetta dolce, kuchengabel | 0/12/120/2520/15120 | 120 | 140 | 2 |
| F | 6331 | CUCHARA CAFÉ tea spoon, cuillère café, cucchiaio caffè, kaffeelöffel | 0/12/120/2520/15120 | 120 | 140 | 2 |
| G | 6330 | CUCHARA MOKA coffee/moka spoon, cuillère moka, cucchiaio moka, mokkalöffel | 0/12/120/2520/15120 | 120 | 110 | 2 |
| | 6499 | MAZO 2 CUCHILLO CHULETERO film 2 steak knife, film 2 couteau steak, film 2 coltello bistecca, film 2 steakmesser | 1/0/48/1008/3024 | 48 | 220 | |
| | 6344 | MAZO 2 CUCHILLO MESA film 2 table knife, film 2 couteau table, film 2 coltello tavola, film 2 tafelmesser | 1/0/48/1008/3024 | 48 | 220 | |
| | 6345 | MAZO 3 CUCHARA MESA film 3 table spoon, film 3 cuillère table, film 3 cucchiaio tavola, film 3 tafellöffel | 1/0/48/1200/3600 | 48 | 200 | 3 |
| | 6346 | MAZO 3 TENEDOR MESA film 3 table fork, film 3 fourchette table, film 3 forchetta tavola, film 3 tafelgabel | 1/0/48/1200/3600 | 48 | 200 | 3 |
| | 6347 | MAZO 6 TENEDOR LUNCH film 6 cake fork, film 6 fourchette gâteau, film 6 forchetta dolce, film 6 kuchengabel | 1/0/48/1152/4608 | 48 | 140 | 2 |
| | 6348 | MAZO 6 CUCHARA CAFÉ film 6 tea spoon, film 6 cuillère café, film 6 cucchiaio caffè, film 6 kaffeelöffel | 1/0/48/1152/4608 | 48 | 140 | 2 |
| | 6349 | MAZO 6 CUCHARA MOKA film 6 coffee/moka spoon, film 6 cuillère moka, film 6 cucchiaio moka, film 6 mokkalöffel | 1/0/48/1152/4608 | 48 | 110 | 2 |
| | 6332 | 24 PIEZAS 24 pieces, écrin 24 pièces, bauletto 24 pz., 24 stück | 1/0/4 | 4 | 3 | |

UE MOQ ▶ mm ✂ mm



INOX
STAINLESS
STEEL
430

| | | | | | | |
|---|-------------|--|---------------------|----|-----|---|
| A | 7207 | CUCHILLO MESA table knife, couteau table, coltello tavola, tafelmesser | 0/12/120/1920/5760 | 60 | 220 | |
| B | 7208 | CUCHARA MESA table spoon, cuillère table, cucchiaio tavola, tafellöffel | 0/12/120/1440/7200 | 60 | 200 | 3 |
| C | 7209 | TENEDOR MESA table fork, fourchette table, forchetta tavola, tafelgabel | 0/12/120/1440/7200 | 60 | 200 | 3 |
| D | 7210 | CUCHARA CAFÉ tea spoon, cuillère café, cucchiaio caffè, kaffeelöffel | 0/12/120/2520/15120 | 60 | 140 | 2 |
| | 7211 | 24 PIEZAS 24 pieces, écrin 24 pièces, bauletto 24 pz., 24 stück | 1/0/4 | 4 | 3 | |

UE MOQ ▶ mm ✂ mm



Madrid

INOX Nickel Free 18% / 3mm / Mirror

Madrid

INOX Nickel Free 18% / 3mm / Mirror



INOX
STAINLESS
STEEL
430

| | UE | MOQ | ▶ mm | ✂ mm |
|---|---------------------|-----|------|------|
| A 1339 CUCHILLO CHULETERO steak knife, couteau steak, coltello bistecca, steakmesser | 0/12/120/1920/5760 | 120 | 224 | |
| B 2775 CUCHILLO MESA table knife, couteau table, coltello tavola, tafelmesser | 0/12/120/1920/5760 | 120 | 221 | |
| C 1340 CUCHARA MESA table spoon, cuillère table, cucchiaio tavola, tafellöffel | 0/12/120/1440/7200 | 120 | 200 | 3 |
| D 1341 TENEDOR MESA table fork, fourchette table, forchetta tavola, tafelgabel | 0/12/120/1440/7200 | 120 | 200 | 3 |
| E 6114 PALA PESCADO fish knife, couteau poisson, coltello pesce, fischmesser | 0/12/120/1440/7200 | 120 | 200 | 3 |
| F 9653 TENEDOR PESCADO fish fork, fourchette poisson, forchetta pesce, fischgabel | 0/12/120/1440/7200 | 120 | 200 | 3 |
| G 6115 CUCHILLO POSTRE dessert knife, couteau dessert, coltello frutta, dessertmesser | 0/12/120/1920/5760 | 120 | 204 | |
| H 1595 CUCHARA POSTRE dessert spoon, cuillère dessert, cucchiaio frutta, dessertlöffel | 0/12/120/1440/7200 | 120 | 183 | 3 |
| I 6117 TENEDOR POSTRE dessert fork, fourchette dessert, forchetta frutta, dessertgabel | 0/12/120/1440/7200 | 120 | 185 | 3 |
| J 9655 TENEDOR LUNCH cake fork, fourchette gâteau, forchetta dolce, kuchengabel | 0/12/120/2520/15120 | 120 | 140 | 2 |
| K 1342 CUCHARA CAFÉ tea spoon, cuillère café, cucchiaio caffè, kaffeelöffel | 0/12/120/2520/15120 | 120 | 135 | 2 |
| L 9654 CUCHARA MOKA coffee/moka spoon, cuillère moka, cucchiaio moka, mokkalöffel | 0/12/120/2520/15120 | 120 | 110 | 2 |
| M 1619 CAZO SOPA soup ladle, louche à potage, mestolo, suppenkelle | 1/10/50/150/750 | 10 | 268 | 3 |
| N 1620 CUCHARA ENSALADA salad spoon, cuillère à servir salade, cucchiaio servire, salatlöffel | 1/10/50/800/4000 | 10 | 270 | 3 |
| O 1622 TENEDOR ENSALADA salad fork, fourchette à servir salade, forchetta servire, salatgabel | 1/10/50/800/4000 | 10 | 265 | 3 |
| P 1621 PALA LASAÑA lasagna server, pelle à lasagne, pala lasagna, lasagneheber | 1/10/50/600/2400 | 10 | 235 | 3 |
| Q 1625 CAZO SALSAS sauce ladle, cuillère à sauce, mestolino salsa, soßenkelle | 1/10/50/800/4000 | 10 | 180 | 3 |
| 1193 MAZO 2 CUCHILLO CHULETERO film 2 steak knife, film 2 couteau steak, film 2 coltello bistecca, film 2 steakmesser | 1/0/48/1008/3024 | 48 | 224 | |
| 1194 MAZO 3 CUCHARA MESA film 3 table spoon, film 3 cuillère table, film 3 cucchiaio tavola, film 3 tafellöffel | 1/0/48/1200/3600 | 48 | 200 | 3 |
| 1195 MAZO 3 TENEDOR MESA film 3 table fork, film 3 fourchette table, film 3 forchetta tavola, film 3 tafelgabel | 1/0/48/1200/3600 | 48 | 200 | 3 |
| 1078 MAZO 2 CUCHILLO POSTRE film 2 dessert knife, film 2 couteau dessert, film 2 coltello frutta, film 2 dessertmesser | 1/0/48/1008/3024 | 48 | 204 | |
| 1079 MAZO 3 CUCHARA POSTRE film 3 dessert spoon, film 3 cuillère dessert, film 3 cucchiaio frutta, film 3 dessertlöffel | 1/0/48/1200/3600 | 48 | 183 | 3 |
| 1080 MAZO 3 TENEDOR POSTRE film 3 dessert fork, film 3 fourchette dessert, film 3 forchetta frutta, film 3 dessertgabel | 1/0/48/1200/3600 | 48 | 185 | 3 |
| 1196 MAZO 6 TENEDOR LUNCH film 6 cake fork, film 6 fourchette gâteau, film 6 forchetta dolce, film 6 kuchengabel | 1/0/48/1152/4608 | 48 | 140 | 2 |
| 1197 MAZO 6 CUCHARA CAFÉ film 6 tea spoon, film 6 cuillère café, film 6 cucchiaio caffè, film 6 kaffeelöffel | 1/0/48/1152/4608 | 48 | 135 | 2 |
| 1198 MAZO 6 CUCHARA MOKA film 6 coffee/moka spoon, film 6 cuillère moka, film 6 cucchiaio moka, film 6 mokkalöffel | 1/0/48/1152/4608 | 48 | 110 | 2 |



2895 24 PIEZAS
24 pieces, écriin 24 pièces, bauletto 24 pz., 24 stück

UE 1/0/4
MOQ 4
▶ mm
✂ mm 2,5





INOX
STAINLESS
STEEL
430

| | | | | | | |
|---|--------------|--|---------------------|-----|-----|---|
| A | 2283 | CUCHILLO MESA table knife, couteau table, coltello tavola, tafelmesser | 0/12/120/1920/5760 | 120 | 240 | |
| B | 2274 | CUCHARA MESA table spoon, cuillère table, cucchiaio tavola, tafellöffel | 0/12/120/1440/7200 | 120 | 200 | 3 |
| C | 2275 | TENEDOR MESA table fork, fourchette table, forchetta tavola, tafelgabel | 0/12/120/1440/7200 | 120 | 200 | 3 |
| D | 2758 | PALA PESCADO fish knife, couteau poisson, coltello pesce, fischmesser | 0/12/120/1440/7200 | 120 | 206 | 3 |
| E | 2284 | CUCHILLO POSTRE dessert knife, couteau dessert, coltello frutta, dessertmesser | 0/12/120/1920/5760 | 120 | 210 | |
| F | 2759 | CUCHARA POSTRE dessert spoon, cuillère dessert, cucchiaio frutta, dessertlöffel | 0/12/120/1440/7200 | 120 | 180 | 3 |
| G | 2760 | TENEDOR POSTRE dessert fork, fourchette dessert, forchetta frutta, dessertgabel | 0/12/120/1440/7200 | 120 | 178 | 3 |
| H | 2761 | TENEDOR LUNCH cake fork, fourchette gâteau, forchetta dolce, kuchengabel | 0/12/120/2520/15120 | 120 | 137 | 2 |
| I | 2762 | CUCHARA CAFÉ tea spoon, cuillère café, cucchiaio caffè, kaffeelöffel | 0/12/120/2520/15120 | 120 | 134 | 2 |
| J | 2763 | CUCHARA MOKA coffee/moka spoon, cuillère moka, cucchiaio moka, mokkalöffel | 0/12/120/2520/15120 | 120 | 115 | 2 |
| | M2283 | MAZO 2 CUCHILLO MESA film 2 table knife, film 2 couteau table, film 2 coltello tavola, film 2 tafelmesser | 1/0/48/1008/3024 | 48 | 240 | |
| | M2274 | MAZO 3 CUCHARA MESA film 3 table spoon, film 3 cuillère table, film 3 cucchiaio tavola, film 3 tafellöffel | 1/0/48/1200/3600 | 48 | 200 | 3 |
| | M2275 | MAZO 3 TENEDOR MESA film 3 table fork, film 3 fourchette table, film 3 forchetta tavola, film 3 tafelgabel | 1/0/48/1200/3600 | 48 | 200 | 3 |
| | M5084 | MAZO 2 CUCHILLO POSTRE film 2 dessert knife, film 2 couteau dessert, film 2 coltello frutta, film 2 dessertmesser | 1/0/48/1008/3024 | 48 | 210 | |
| | M2759 | MAZO 3 CUCHARA POSTRE film 3 dessert spoon, film 3 cuillère dessert, film 3 cucchiaio frutta, film 3 dessertlöffel | 1/0/48/1200/3600 | 48 | 180 | 3 |
| | M2760 | MAZO 3 TENEDOR POSTRE film 3 dessert fork, film 3 fourchette dessert, film 3 forchetta frutta, film 3 dessertgabel | 1/0/48/1200/3600 | 48 | 178 | 3 |
| | M2761 | MAZO 6 TENEDOR LUNCH film 6 cake fork, film 6 fourchette gâteau, film 6 forchetta dolce, film 6 kuchengabel | 1/0/48/1152/4608 | 48 | 137 | 2 |
| | M2762 | MAZO 6 CUCHARA CAFÉ film 6 tea spoon, film 6 cuillère café, film 6 cucchiaio caffè, film 6 kaffeelöffel | 1/0/48/1152/4608 | 48 | 134 | 2 |
| | M2763 | MAZO 6 CUCHARA MOKA film 6 coffee/moka spoon, film 6 cuillère moka, film 6 cucchiaio moka, film 6 mokkalöffel | 1/0/48/1152/4608 | 48 | 115 | 2 |

UE **MOQ** **▶ mm** **✂ mm**



2764 **24 PIEZAS**
24 pieces, écriin 24 pièces, bauletto 24 pz., 24 stück

UE **MOQ** **▶ mm** **✂ mm**
1/0/4 4 2,5





INOX
STAINLESS
STEEL
430

| | | |
|---|--------------|--|
| A | 2774 | CUCHILLO MESA table knife, couteau table, coltello tavola, tafelmesser |
| B | 2710 | CUCHARA MESA table spoon, cuillère table, cucchiaio tavola, tafellöffel |
| C | 2711 | TENEDOR MESA table fork, fourchette table, forchetta tavola, tafelgabel |
| D | 2734 | PALA PESCADO fish knife, couteau poisson, coltello pesce, fischmesser |
| E | 5826 | CUCHILLO POSTRE dessert knife, couteau dessert, coltello frutta, dessertmesser |
| F | 2712 | CUCHARA POSTRE dessert spoon, cuillère dessert, cucchiaio frutta, dessertlöffel |
| G | 2713 | TENEDOR POSTRE dessert fork, fourchette dessert, forchetta frutta, dessertgabel |
| H | 2714 | TENEDOR LUNCH cake fork, fourchette gâteau, forchetta dolce, kuchengabel |
| I | 2715 | CUCHARA CAFÉ tea spoon, cuillère café, cucchiaio caffè, kaffeelöffel |
| J | 2716 | CUCHARA MOKA coffee/moka spoon, cuillère moka, cucchiaio moka, mokkalöffel |
| | M2297 | MAZO 2 CUCHILLO MESA film 2 table knife, film 2 couteau table, film 2 coltello tavola, film 2 tafelmesser |
| | M2710 | MAZO 3 CUCHARA MESA film 3 table spoon, film 3 cuillère table, film 3 cucchiaio tavola, film 3 tafellöffel |
| | M2711 | MAZO 3 TENEDOR MESA film 3 table fork, film 3 fourchette table, film 3 forchetta tavola, film 3 tafelgabel |
| | M2161 | MAZO 2 CUCHILLO POSTRE film 2 dessert knife, film 2 couteau dessert, film 2 coltello frutta, film 2 dessertmesser |
| | M2712 | MAZO 3 CUCHARA POSTRE film 3 dessert spoon, film 3 cuillère dessert, film 3 cucchiaio frutta, film 3 dessertlöffel |
| | M2713 | MAZO 3 TENEDOR POSTRE film 3 dessert fork, film 3 fourchette dessert, film 3 forchetta frutta, film 3 dessertgabel |
| | M2714 | MAZO 6 TENEDOR LUNCH film 6 cake fork, film 6 fourchette gâteau, film 6 forchetta dolce, film 6 kuchengabel |
| | M2715 | MAZO 6 CUCHARA CAFÉ film 6 tea spoon, film 6 cuillère café, film 6 cucchiaio caffè, film 6 kaffeelöffel |
| | M2716 | MAZO 6 CUCHARA MOKA film 6 coffee/moka spoon, film 6 cuillère moka, film 6 cucchiaio moka, film 6 mokkalö- |

| UE | MOQ | ▶ mm | ✂ mm |
|---------------------|-----|------|------|
| 0/12/120/1920/5760 | 120 | 229 | |
| 0/12/120/1440/7200 | 120 | 213 | 3 |
| 0/12/120/1440/7200 | 120 | 213 | 3 |
| 0/12/120/1440/7200 | 120 | 215 | 2,5 |
| 0/12/120/1920/5760 | 60 | 200 | |
| 0/12/120/1440/7200 | 120 | 190 | 2,5 |
| 0/12/120/1440/7200 | 120 | 190 | 2,5 |
| 0/12/120/2520/15120 | 120 | 140 | 2 |
| 0/12/120/2520/15120 | 120 | 140 | 2 |
| 0/12/120/2520/15120 | 120 | 109 | 1,5 |
| 1/0/48/1008/3024 | 48 | 229 | |
| 1/0/48/1200/3600 | 48 | 213 | 3 |
| 1/0/48/1200/3600 | 48 | 213 | 3 |
| 1/0/48/1008/3024 | 48 | 200 | |
| 1/0/48/1200/3600 | 48 | 190 | 2,5 |
| 1/0/48/1200/3600 | 48 | 190 | 2,5 |
| 1/0/48/1152/4608 | 48 | 140 | 2 |
| 1/0/48/1152/4608 | 48 | 140 | 2 |
| 1/0/48/1152/4608 | 48 | 109 | 1,5 |



2757 24 PIEZAS
24 pieces, écriin 24 pièces, bauiletto 24 pz., 24 stück

| UE | MOQ | ▶ mm | ✂ mm |
|-------|-----|------|------|
| 1/0/4 | 4 | | 3 |



Napoli Pizza Collection

INOX Nickel Free 18% / 4mm / Mirror



INOX STAINLESS STEEL 430

- A **3263** CUCHILLO PIZZA
pizza knife, couteau pizza, coltello pizza, pizza tafelmesser
- B **3264** TENEDOR PIZZA
pizza fork, fourchette pizza, forchetta pizza, pizza gabel
- C **3265** BLISTER 3 CUCHILLO PIZZA
blister 3 pizza knife, blister 3 couteau pizza, blister 3 coltello pizza, blister pizza-messer
- D **3266** BLISTER CUCHILLO + TENEDOR PIZZA
blister pizza knife + fork, blister couteau + fourchette pizza, blister coltello + forchetta pizza, blister pizza messer + gabel

| UE | MOQ | ▶ mm | ✕ mm |
|--------------------|-----|------|------|
| 0/12/120/1920/5760 | 120 | 205 | |
| 0/12/120/1920/5760 | 120 | 202 | 4 |
| 1/0/24/4561/2280 | 24 | 205 | |
| 1/0/48/576/2304 | 48 | 205 | 4 |

Vieux Paris

INOX Nickel Free 18% / 3mm / Mirror + Satin



Acabado mirror
Mirror finish

Acabado satinado
Satin finish

INOX STAINLESS STEEL 430

- A **5795** CUCHILLO MESA
table knife, couteau table, coltello tavola, tafelmesser
- B **5796** CUCHARA MESA
table spoon, cuillère table, cucchiaio tavola, tafellöffel
- C **5797** TENEDOR MESA
table fork, fourchette table, forchetta tavola, tafelgabel
- D **5798** CUCHILLO POSTRE
dessert knife, couteau dessert, coltello frutta, dessertmesser
- E **5799** CUCHARA POSTRE
dessert spoon, cuillère dessert, cucchiaio frutta, dessertlöffel
- F **5800** TENEDOR POSTRE
dessert fork, fourchette dessert, forchetta frutta, dessertgabel
- G **5801** CUCHARA CAFÉ
tea spoon, cuillère café, cucchiaio caffè, kaffeelöffel
- H **5802** CUCHARA MOKA
coffee/moka spoon, cuillère moka, cucchiaio moka, mokkalöffel

| UE | MOQ | ▶ mm | ✕ mm |
|---------------------|-----|------|------|
| 0/12/120/1920/5760 | 60 | 238 | |
| 0/12/120/1440/7200 | 60 | 210 | 3 |
| 0/12/120/1440/7200 | 60 | 208 | 3 |
| 0//120/1920/5760 | 60 | 215 | |
| 0/12/120/1440/7200 | 60 | 178 | 2,5 |
| 0/12/120/1440/7200 | 60 | 178 | 2,5 |
| 0/12/120/2520/15120 | 60 | 143 | 2 |
| 0/12/120/2520/15120 | 60 | 112 | 2 |

Sevilla XL

INOX Nickel Free 18% / 3mm / Mirror



Sevilla XL

INOX Nickel Free 18% / 3mm / Mirror



| | UP | MOQ | mm | mm | | |
|---|-------|--|---------------------|-----|-----|-----|
| A | 0094 | CUCHILLO MESA | 0/12/120/1920/5760 | 60 | 225 | |
| | | table knife, couteau table, coltello tavola, tafelmesser | | | | |
| B | 5631 | CUCHILLO CHULETERO | 0/12/120/1920/5760 | 60 | 230 | |
| | | steak knife, couteau steak, coltello bistecca, steakmesser | | | | |
| C | 9657 | CUCHARA MESA | 0/12/120/1440/7200 | 120 | 209 | 3 |
| | | table spoon, cuillère table, cucchiaio tavola, tafellöffel | | | | |
| D | 9658 | TENEDOR MESA | 0/12/120/1440/7200 | 120 | 210 | 3 |
| | | table fork, fourchette table, forchetta tavola, tafelgabel | | | | |
| E | 9659 | PALA PESCADO | 0/12/120/1440/7200 | 120 | 200 | 2,5 |
| | | fish knife, couteau poisson, coltello pesce, fischmesser | | | | |
| F | 9660 | TENEDOR PESCADO | 0/12/120/1440/7200 | 120 | 197 | 2,5 |
| | | fish fork, fourchette poisson, forchetta pesce, fischgabel | | | | |
| G | 0099 | CUCHILLO POSTRE | 0/12/120/1920/5760 | 60 | 195 | |
| | | dessert knife, couteau dessert, coltello frutta, dessertmesser | | | | |
| H | 9662 | CUCHARA POSTRE | 0/12/120/1440/7200 | 120 | 178 | 2,5 |
| | | dessert spoon, cuillère à dessert, cucchiaio frutta, dessertlöffel | | | | |
| I | 9663 | TENEDOR POSTRE | 0/12/120/1440/7200 | 120 | 183 | 2,5 |
| | | dessert fork, fourchette à dessert, forchetta frutta, dessertgabel | | | | |
| J | 11930 | TENEDOR LUNCH | 0/12/120/2520/15120 | 120 | 148 | 2 |
| | | cake fork, fourchette gâteau, forchetta dolce, kuchengabel | | | | |
| K | 9665 | CUCHARA CAFÉ | 0/12/120/2520/15120 | 120 | 138 | 2 |
| | | tea spoon, cuillère café, cucchiaio caffè, kaffeelöffel | | | | |
| L | 9666 | CUCHARA MOKA | 0/12/120/2520/15120 | 120 | 117 | 2 |
| | | coffee/moka spoon, cuillère moka, cucchiaio moka, mokkalöffel | | | | |
| M | 1626 | CAZO SOPA | 1/10/50/200/800 | 10 | 260 | 2,5 |
| | | soup ladle, louche à potage, mestolo, suppenkelle | | | | |
| N | 1627 | CUCHARA SERVIR | 1/10/50/800/400 | 10 | 235 | 2,5 |
| | | serving spoon, cuillère à servir, cucchiaio servir, servierlöffel | | | | |
| O | 1628 | TENEDOR SERVIR | 1/10/50/800/400 | 10 | 235 | 2,5 |
| | | serving fork, fourchette à servir, forchetta servire, serviergabel | | | | |
| P | 1629 | PALA REPOSTERÍA | 1/10/50/600/2400 | 10 | 240 | 2,7 |
| | | cake server, pelle à tarte, pala torta, tortenheber | | | | |
| Q | 1632 | CAZO SALSA | 1/10/50/800/4000 | 10 | 170 | 2,7 |
| | | sauce ladle, cuillère à sauce, mestolino salsa, soßenkelle | | | | |



| | UP | MOQ | mm | mm | |
|-----------|--|------------------|----|-----|-----|
| 1297 | MAZO 2 CUCHILLO CHULETERO | 1/0/48/1008/3024 | 48 | 230 | |
| | film 2 steak knife, film 2 couteau steak, film 2 coltello bistecca, film 2 steakmesser | | | | |
| 1298 | MAZO 3 CUCHARA MESA | 1/0/48/1200/3600 | 48 | 209 | 3 |
| | film 3 table spoon, film 3 cuillère table, film 3 cucchiaio tavola, film 3 tafellöffel | | | | |
| 1299 | MAZO 3 TENEDOR MESA | 1/0/48/1200/3600 | 48 | 210 | 3 |
| | film 3 table fork, film 3 fourchette table, film 3 forchetta tavola, film 3 tafelgabel | | | | |
| 1315 | MAZO 2 CUCHILLO POSTRE | 1/0/48/1008/3024 | 48 | 200 | |
| | film 2 dessert knife, film 2 couteau dessert, film 2 coltello frutta, film 2 dessertmesser | | | | |
| 1316 | MAZO 3 CUCHARA POSTRE | 1/0/48/1200/3600 | 48 | 178 | 2,5 |
| | film 3 dessert spoon, film 3 cuillère à dessert, film 3 cucchiaio frutta, film 3 dessertlöffel | | | | |
| 1317 | MAZO 3 TENEDOR POSTRE | 1/0/48/1200/3600 | 48 | 183 | 2,5 |
| | film 3 dessert fork, film 3 fourchette à dessert, film 3 forchetta frutta, film 3 dessertgabel | | | | |
| NEW 11931 | MAZO 6 TENEDOR LUNCH | 1/0/48/1152/4608 | 48 | 178 | 2 |
| | film 6 cake fork, film 6 fourchette gâteau, film 6 forchetta dolce, film 6 kuchengabel | | | | |
| 1301 | MAZO 6 CUCHARA CAFÉ | 1/0/48/1152/4608 | 48 | 138 | 2 |
| | film 6 tea spoon, film 6 cuillère café, film 6 cucchiaio caffè, film 6 kaffeelöffel | | | | |
| 1302 | MAZO 6 CUCHARA MOKA | 1/0/48/1152/4608 | 48 | 117 | 2 |
| | film 6 coffee/moka spoon, film 6 cuillère moka, film 6 cucchiaio moka, film 6 mokkalöffel | | | | |



Sevilla S

INOX Nickel Free 18% / 1,8mm / Mirror



UE MOQ ✂ mm ✂ mm

| | | | | | | |
|--------------|-------------|--|---------------------|-----|-----|-----|
| A | 4712 | CUCHILLO MESA MICRODENTADO table knife micro, couteau table micro, coltello tavola micro, tafelmesser micro | 0/12/120/1920/5760 | 120 | 224 | |
| B | 0451 | CUCHARA MESA table spoon, cuillère table, cucchiaio tavola, tafellöffel | 0/12/120/1440/7200 | 120 | 193 | 1,5 |
| C | 0452 | TENEDOR MESA table fork, fourchette table, forchetta tavola, tafelgabel | 0/12/120/1440/7200 | 120 | 190 | 1,8 |
| D | 0453 | TENEDOR LUNCH cake fork, fourchette gâteau, forchetta dolce, kuchengabel | 0/12/120/2520/15120 | 120 | 143 | 1,5 |
| E | 0454 | CUCHARA CAFÉ tea spoon, cuillère café, cucchiaio caffè, kaffeelöffel | 0/12/120/2520/15120 | 120 | 140 | 1,5 |
| F | 0455 | CUCHARA MOKA coffee/moka spoon, cuillère moka, cucchiaio moka, mokkalöffel | 0/12/120/2520/15120 | 120 | 120 | 1,2 |
| M3950 | | MAZO 2 CUCHILLO MESA MICRO film 2 table knife micro, film 2 couteau table micro, film 2 coltello tavola micro, film 2 tafelmesser micro | 1/0/48/1008/3024 | 48 | 224 | |
| M4306 | | MAZO 3 CUCHARA MESA film 3 table spoon, film 3 cuillère table, film 3 cucchiaio tavola, film 3 tafellöffel | 1/0/48/1200/3600 | 48 | 193 | 1,5 |
| M4307 | | MAZO 3 TENEDOR MESA film 3 table fork, film 3 fourchette table, film 3 forchetta tavola, film 3 tafelgabel | 1/0/48/1200/3600 | 48 | 190 | 1,8 |
| M4755 | | MAZO 6 TENEDOR LUNCH film 6 cake fork, film 6 fourchette gâteau, film 6 forchetta dolce, film 6 kuchengabel | 1/0/48/1152/4608 | 48 | 143 | 1,5 |
| M4756 | | MAZO 6 CUCHARA CAFÉ film 6 tea spoon, film 6 cuillère café, film 6 cucchiaio caffè, film 6 kaffeelöffel | 1/0/48/1152/4608 | 48 | 140 | 1,5 |
| M4757 | | MAZO 6 CUCHARA MOKA film 6 coffee/moka spoon, film 6 cuillère moka, film 6 cucchiaio moka, film 6 mokkalöffel | 1/0/48/1152/4608 | 48 | 120 | 1,2 |
| 3950 | | CORBATA 2 CUCHILLO MESA ECO MICRO Tie 2 table knife eco micro, cavalier 2 couteau table eco micro, cravatta 2 coltello tavola eco micro, krawatte 2 tafelmesser eco micro | 1/4/48/672/2688 | 48 | 224 | |
| 4306 | | CORBATA 3 CUCHARA MESA Tie 3 table spoon, cavalier 3 cuillère table, cravatta 3 cucchiaio tavola, krawatte 3 tafellöffel | 1/4/48/672/2688 | 48 | 193 | 1,5 |
| 4307 | | CORBATA 3 TENEDOR MESA Tie 3 table fork, cavalier 3 fourchette table, cravatta 3 forchetta tavola, krawatte 3 tafelgabel | 1/4/48/672/2688 | 48 | 190 | 1,8 |
| 4755 | | CORBATA 6 TENEDOR LUNCH Tie 6 cake fork, cavalier 6 fourchette gâteau, cravatta 6 forchetta dolce, krawatte 6 kuchengabel | 1/4/48/672/2688 | 48 | 143 | 1,5 |
| 4756 | | CORBATA 6 CUCHARA CAFÉ Tie 6 tea spoon, cavalier 6 cuillère café, cravatta 6 cucchiaio caffè, krawatte 6 kaffeelöffel | 1/4/48/672/2688 | 48 | 140 | 1,5 |
| 4757 | | CORBATA 6 CUCHARA MOKA Tie 6 moka spoon, cavalier 6 cuillère moka, cravatta 6 cucchiaio moka, krawatte 6 mokkalöffel | 1/4/48/672/2688 | 48 | 120 | 1,2 |
| 4885 | | 24 PIEZAS 24 pieces, écriin 24 pièces, bauletto 24 pz., 24 stück | 1/0/4 | 4 | 1,8 | |
| 4999 | | 24 PIEZAS CON CHULETERO 24 pieces + stak knife, écriin 24 pièces + c.steak, bauletto 24 pz. + bistecca, 24 stück + steakmesser | 1/0/4 | 4 | 1,8 | |

Sevilla Vintage

INOX Nickel Free 18% / 2,5mm / Vintage

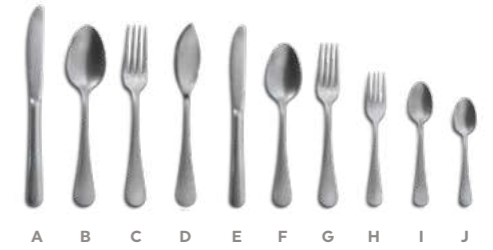

UE MOQ ✂ mm ✂ mm

| | | | | | | |
|-------------|--------------|--|---------------------|-----|-----|-----|
| A | 7425 | CUCHILLO MESA table knife, couteau table, coltello tavola, tafelmesser | 0/12/120/1920/5760 | 120 | 225 | |
| B | 7426 | CUCHARA MESA table spoon, cuillère table, cucchiaio tavola, tafellöffel | 0/12/120/1440/7200 | 120 | 198 | 2,5 |
| C | 7427 | TENEDOR MESA table fork, fourchette table, forchetta tavola, tafelgabel | 0/12/120/1440/7200 | 120 | 198 | 2,5 |
| D | 8567 | PALA PESCADO fish knife, couteau poisson, coltello pesce, fischmesser | 0/12/120/1440/7200 | 120 | 200 | 2,5 |
| E | 8568 | CUCHILLO POSTRE dessert knife, couteau dessert, coltello frutta, dessertmesser | 0/12/120/1440/7200 | 120 | 195 | |
| F | 8569 | CUCHARA POSTRE dessert spoon, cuillère à dessert, cucchiaio frutta, dessertlöffel | 0/12/120/1440/7200 | 120 | 185 | 2,5 |
| G | 8570 | TENEDOR POSTRE dessert fork, fourchette à dessert, forchetta frutta, dessertgabel | 0/12/120/1440/7200 | 120 | 185 | 2,5 |
| H | 11932 | TENEDOR LUNCH cake fork, fourchette gâteau, forchetta dolce, kuchengabel | 0/12/120/2520/15120 | 120 | 148 | 2 |
| I | 7429 | CUCHARA CAFÉ tea spoon, cuillère café, cucchiaio caffè, kaffeelöffel | 0/12/120/2520/15120 | 120 | 138 | 2 |
| J | 7430 | CUCHARA MOKA coffee/moka spoon, cuillère moka, cucchiaio moka, mokkalöffel | 0/12/120/2520/15120 | 120 | 117 | 2 |
| 7917 | | 24 PIEZAS 24 pieces, écriin 24 pièces, bauletto 24 pz., 24 stück | 1/0/4 | 4 | | |

Granada XL

INOX Nickel Free 18% / 2,5mm / Mirror



Granada XL

INOX Nickel Free 18% / 2,5mm / Mirror



INOX STAINLESS STEEL 430

| | | UE | MOQ | ✂ mm | ✂ mm |
|---|--|---------------------|-----|------|------|
| A | 1283 CUCHILLO CHULETERO steak knife, couteau steak, coltello bistecca, steakmesser | 0/12/120/1920/5760 | 60 | 223 | |
| B | 3522 CUCHILLO MESA table knife, couteau table, coltello tavola, tafelmesser | 0/12/120/1920/5760 | 60 | 225 | |
| C | 2700 CUCHARA MESA table spoon, cuillère table, cucchiaio tavola, tafellöffel | 0/12/120/1440/7200 | 120 | 209 | 2,5 |
| D | 2701 TENEDOR MESA table fork, fourchette table, forchetta tavola, tafelgabel | 0/12/120/1440/7200 | 120 | 210 | 2,5 |
| E | 2702 PALA PESCADO fish knife, couteau poisson, coltello pesce, fischmesser | 0/12/120/1440/7200 | 120 | 200 | 2,5 |
| F | 2703 TENEDOR PESCADO fish fork, fourchette poisson, forchetta pesce, fischgabel | 0/12/120/1440/7200 | 120 | 200 | 2,5 |
| G | 3523 CUCHILLO POSTRE dessert knife, couteau dessert, coltello frutta, dessertmesser | 0/12/120/1920/5760 | 120 | 196 | |
| H | 2705 CUCHARA POSTRE dessert spoon, cuillère à dessert, cucchiaio frutta, dessertlöffel | 0/12/120/1440/7200 | 120 | 178 | 2,5 |
| I | 2706 TENEDOR POSTRE dessert fork, fourchette à dessert, forchetta frutta, dessertgabel | 0/12/120/1440/7200 | 120 | 183 | 2,5 |
| J | 11933 TENEDOR LUNCH cake fork, fourchette gâteau, forchetta dolce, kuchengabel | 0/12/120/2520/15120 | 120 | 148 | 2 |
| K | 2708 CUCHARA CAFÉ tea spoon, cuillère café, cucchiaio caffè, kaffeelöffel | 0/12/120/2520/15120 | 120 | 138 | 2 |
| L | 2709 CUCHARA MOKA coffee/moka spoon, cuillère moka, cucchiaio moka, mokkalöffel | 0/12/120/2520/15120 | 120 | 117 | 2 |
| M | 2303 CAZO SOPA soup ladle, louche à potage, mestolo, suppenkelle | 1/10/50/150/750 | 10 | 260 | 2,5 |
| N | 2304 CUCHARA SERVIR serving spoon, cuillère à servir, cucchiaio servir, servierlöffel | 1/10/50/?800?4000 | 10 | 230 | 2,8 |
| O | 2305 TENEDOR SERVIR serving fork, fourchette à servir, forchetta servire, serviergabel | 1/10/50/?800?4000 | 10 | 230 | 2,5 |
| P | 2306 PALA REPOSTERÍA cake server, pelle à tarte, pala torta, tortenheber | 1/10/50/600/2400 | 10 | 240 | 2,7 |
| Q | 2307 CAZO SALSA sauce ladle, cuillère à sauce, mestolino salsa, soßenkelle | 1/10/50/800/4000 | 10 | 170 | 2,7 |

INOX STAINLESS STEEL 430

| | | UE | MOQ | ✂ mm | ✂ mm |
|--------------|---|------------------|-----|------|------|
| M1462 | MAZO 2 CUCHILLO CHULETERO film 2 steak knife, film 2 couteau steak, film 2 coltello bistecca, film 2 steakmesser | 1/0/48/1008/3024 | 48 | 223 | |
| 1597 | MAZO 3 CUCHARA MESA film 3 table spoon, film 3 cuillère table, film 3 cucchiaio tavola, film 3 tafellöffel | 1/0/48/1200/3600 | 48 | 209 | 2,5 |
| 1598 | MAZO 3 TENEDOR MESA film 3 table fork, film 3 fourchette table, film 3 forchetta tavola, film 3 tafelgabel | 1/0/48/1200/3600 | 48 | 210 | 2,5 |
| M4564 | MAZO 2 CUCHILLO POSTRE film 2 dessert knife, film 2 couteau dessert, film 2 coltello frutta, film 2 dessertmesser | 1/0/48/1008/3024 | 48 | 196 | |
| 1601 | MAZO 3 CUCHARA POSTRE film 3 dessert spoon, film 3 cuillère à dessert, film 3 cucchiaio frutta, film 3 dessertlöffel | 1/0/48/1200/3600 | 48 | 178 | 2,5 |
| 1602 | MAZO 3 TENEDOR POSTRE film 3 dessert fork, film 3 fourchette à dessert, film 3 forchetta frutta, film 3 dessertgabel | 1/0/48/1200/3600 | 48 | 183 | 2,5 |
| 11934 | MAZO 6 TENEDOR LUNCH film 6 cake fork, film 6 fourchette gâteau, film 6 forchetta dolce, film 6 kuchengabel | 1/0/48/1152/4608 | 48 | 145 | 2 |
| 1604 | MAZO 6 CUCHARA CAFÉ film 6 tea spoon, film 6 cuillère café, film 6 cucchiaio caffè, film 6 kaffeelöffel | 1/0/48/1152/4608 | 48 | 138 | 2 |
| 1605 | MAZO 6 CUCHARA MOKA film 6 coffee/moka spoon, film 6 cuillère moka, film 6 cucchiaio moka, film 6 mokkalöffel | 1/0/48/1152/4608 | 48 | 117 | 2 |

Granada S

INOX Nickel Free 18% / 1,8mm / Mirror

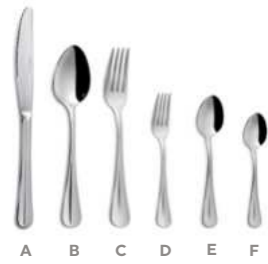

Granada S

INOX Nickel Free 18% / 1,8mm / Mirror

INOX
STAINLESS
STEEL
430

- A **4632** CUCHILLO MESA
table knife, couteau table, coltello tavola, tafelmesser
- B **0424** CUCHARA MESA
table spoon, cuillère table, cucchiaio tavola, tafellöffel
- C **0425** TENEDOR MESA
table fork, fourchette table, forchetta tavola, tafelgabel
- D **0426** TENEDOR LUNCH
cake fork, fourchette gâteau, forchetta dolce, kuchengabel
- E **0427** CUCHARA CAFÉ
tea spoon, cuillère café, cucchiaio caffè, kaffeelöffel
- F **0428** CUCHARA MOKA
coffee/moka spoon, cuillère moka, cucchiaio moka, mokkalöffel
- 8083** MAZO 2 CUCHILLO MESA
film 2 knife, film 2 couteau, film 2 coltello, film 2 messer
- 8084** MAZO 3 CUCHARA MESA
film 3 table spoon, film 3 cuillère table, film 3 cucchiaio tavola, film 3 tafellöffel
- 8085** MAZO 3 TENEDOR MESA
film 3 table fork, film 3 fourchette table, film 3 forchetta tavola, film 3 tafelgabel
- 8086** MAZO 6 TENEDOR LUNCH
film 6 cake fork, film 6 fourchette gâteau, film 6 forchetta dolce, film 6 kuchengabel
- 8087** MAZO 6 CUCHARA CAFÉ
film 6 tea spoon, film 6 cuillère café, film 6 cucchiaio caffè, film 6 kaffeelöffel
- 8088** MAZO 6 CUCHARA MOKA
film 6 coffee/moka spoon, film 6 cuillère moka, film 6 cucchiaio moka, film 6 mokkalöffel
- 5107** CORBATA 2 CUCHILLO MESA
Tie 2 table knife, cavalier 2 couteau table, cravatta 2 coltello tavola, krawatte 2 tafelmesser
- 4623** CORBATA 3 CUCHARA MESA
Tie 3 table spoon, cavalier 3 cuillère table, cravatta 3 cucchiaio tavola, krawatte 3 takkellöffel
- 4624** CORBATA 3 TENEDOR MESA
Tie 3 table fork, cavalier 3 fourchette table, cravatta 3 forchetta tavola, krawatte 3 tafelgabel
- 3515** CORBATA 6 TENEDOR LUNCH
Tie 6 cake fork, cavalier 6 fourchette gâteau, cravatta 6 forchetta dolce, krawatte 6 kuchengabel
- 3516** CORBATA 6 CUCHARA CAFÉ
Tie 6 tea spoon, cavalier 6 cuillère café, cravatta 6 cucchiaio caffè, krawatte 6 kaffeelöffel
- 3517** CORBATA 6 CUCHARA MOKA
Tie 6 moka spoon, cavalier 6 cuillère moka, cravatta 6 cucchiaio moka, krawatte 6 mokkalöffel
- 4884** 24 PIEZAS
24 pieces, écrin 24 pièces, bauletto 24 pz., 24 stück

| UE | MOQ | ▶ mm | ✂ mm |
|---------------------|-----|------|------|
| 0/12/120/1920/5760 | 120 | 224 | |
| 0/12/120/1440/7200 | 120 | 193 | 1,5 |
| 0/12/120/1440/7200 | 120 | 190 | 1,8 |
| 0/12/120/2520/15120 | 120 | 143 | 1,5 |
| 0/12/120/2520/15120 | 120 | 140 | 1,5 |
| 0/12/120/2520/15120 | 120 | 120 | 1,2 |
| 1/0/48/1008/3024 | 48 | 224 | |
| 1/0/48/1200/3600 | 48 | 193 | 1,5 |
| 1/0/48/1200/3600 | 48 | 190 | 1,8 |
| 1/0/48/1152/4608 | 48 | 143 | 1,5 |
| 1/0/48/1152/4608 | 48 | 140 | 1,5 |
| 1/0/48/1152/4608 | 48 | 120 | 1,2 |
| 1/4/48/672/2688 | 48 | 224 | |
| 1/4/48/672/2688 | 48 | 193 | 1,5 |
| 1/4/48/672/2688 | 48 | 190 | 1,8 |
| 1/4/48/672/2688 | 48 | 143 | 1,5 |
| 1/4/48/672/2688 | 48 | 140 | 1,5 |
| 1/4/48/672/2688 | 48 | 120 | 1,2 |
| 1/0/4 | 4 | | 1,8 |



Bilbao XL

INOX Nickel Free 18% / 2,5mm / Mirror



INOX STAINLESS STEEL 430

| | | |
|---|--------------|---|
| A | 2396 | CUCHILLO CHULETERO steak knife, couteau steak, coltello bistecca, steakmesser |
| B | 2338 | CUCHILLO MESA table knife, couteau table, coltello tavola, tafelmesser |
| C | 2632 | CUCHARA MESA table spoon, cuillère table, cucchiaio tavola, tafellöffel |
| D | 2633 | TENEDOR MESA table fork, fourchette table, forchetta tavola, tafelgabel |
| E | 2634 | PALA PESCADO fish knife, couteau poisson, coltello pesce, fischmesser |
| F | 2635 | TENEDOR PESCADO fish fork, fourchette poisson, forchetta pesce, fischgabel |
| G | 2511 | CUCHILLO POSTRE dessert knife, couteau dessert, coltello frutta, dessertmesser |
| H | 2637 | CUCHARA POSTRE dessert spoon, cuillère à dessert, cucchiaio frutta, dessertlöffel |
| I | 2638 | TENEDOR POSTRE dessert fork, fourchette à dessert, forchetta frutta, dessertgabel |
| J | 11928 | TENEDOR LUNCH cake fork, fourchette gâteau, forchetta dolce, kuchengabel |
| K | 2640 | CUCHARA CAFÉ tea spoon, cuillère café, cucchiaio caffè, kaffeelöffel |
| L | 2641 | CUCHARA MOKA coffee/moka spoon, cuillère moka, cucchiaio moka, mokkalöffel |
| M | 2298 | CAZO SOPA soup ladle, louche à potage, mestolo, suppenkelle |
| N | 2040 | CUCHARA SERVIR serving spoon, cuillère à servir, cucchiaio servir, servierlöffel |
| O | 2300 | TENEDOR SERVIR serving fork, fourchette à servir, forchetta servire, serviergabel |
| P | 2301 | PALA REPOSTERÍA cake server, pelle à tarte, pala torta, tortenheber |
| Q | 2302 | CAZO SALSA sauce ladle, cuillère à sauce, mestolino salsa, soßenkelle |

UP
GRADE

Bilbao XL

INOX Nickel Free 18% / 2,5mm / Mirror



INOX STAINLESS STEEL 430

| | | |
|---|--------------|--|
| A | M2397 | MAZO 2 CUCHILLO CHULETERO film 2 steak knife, film 2 couteau steak, film 2 coltello bistecca, film 2 steakmesser |
| C | 1635 | MAZO 3 CUCHARA MESA film 3 table spoon, film 3 cuillère table, film 3 cucchiaio tavola, film 3 tafellöffel |
| D | 1642 | MAZO 3 TENEDOR MESA film 3 table fork, film 3 fourchette table, film 3 forchetta tavola, film 3 tafelgabel |
| G | M4591 | MAZO 2 CUCHILLO POSTRE film 2 dessert knife, film 2 couteau dessert, film 2 coltello frutta, film 2 dessertmesser |
| H | 1644 | MAZO 3 CUCHARA POSTRE film 3 dessert spoon, film 3 cuillère à dessert, film 3 cucchiaio frutta, film 3 dessertlöffel |
| I | 1646 | MAZO 3 TENEDOR POSTRE film 3 dessert fork, film 3 fourchette à dessert, film 3 forchetta frutta, film 3 dessertgabel |
| J | 11929 | MAZO 6 TENEDOR LUNCH film 6 cake fork, film 6 fourchette gâteau, film 6 forchetta dolce, film 6 kuchengabel |
| K | 1648 | MAZO 6 CUCHARA CAFÉ film 6 tea spoon, film 6 cuillère café, film 6 cucchiaio caffè, film 6 kaffeelöffel |
| L | 1649 | MAZO 6 CUCHARA MOKA film 6 coffee/moka spoon, film 6 cuillère moka, film 6 cucchiaio moka, film 6 mokkalöffel |

| UE | MOQ | ▶ mm | ✂ mm |
|------------------|-----|------|------|
| 1/0/48/1008/3024 | 48 | 223 | |
| 1/0/48/1200/3600 | 48 | 209 | 2,5 |
| 1/0/48/1200/3600 | 48 | 210 | 2,5 |
| 1/0/48/1008/3024 | 48 | 200 | |
| 1/0/48/1200/3600 | 48 | 178 | 2,5 |
| 1/0/48/1200/3600 | 48 | 183 | 2,5 |
| 1/0/48/1152/4608 | 48 | 148 | 2 |
| 1/0/48/1152/4608 | 48 | 138 | 2 |
| 1/0/48/1152/4608 | 48 | 117 | 2 |



Bilbao S

INOX Nickel Free 18% / 1,8mm / Mirror



Olympia

INOX Nickel Free 18% / 1,8mm / Mirror

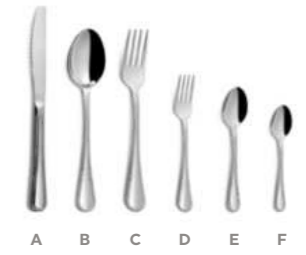

INOX STAINLESS STEEL 430

| | UE | MOQ | ▶ mm | ✂ mm |
|--|---------------------|-----|------|------|
| A 1623 CUCHILLO MESA table knife, couteau table, coltello tavola, tafelmesser | 0/12/120/1920/5760 | 120 | 224 | |
| B 3130 CUCHARA MESA table spoon, cuillère table, cucchio tavola, tafellöffel | 0/12/120/1440/7200 | 120 | 193 | 1,5 |
| C 3131 TENEDOR MESA table fork, fourchette table, forchetta tavola, tafelgabel | 0/12/120/1440/7200 | 120 | 190 | 1,8 |
| D 3814 TENEDOR LUNCH cake fork, fourchette gâteau, forchetta dolce, kuchengabel | 0/12/120/2520/15120 | 120 | 143 | 1,5 |
| E 3812 CUCHARA CAFÉ tea spoon, cuillère café, cucchio caffè, kaffeelöffel | 0/12/120/2520/15120 | 120 | 140 | 1,5 |
| F 3813 CUCHARA MOKA coffee/moka spoon, cuillère moka, cucchio moka, mokkalöffel | 0/12/120/2520/15120 | 120 | 120 | 1,2 |
| M0010 MAZO 2 CUCHILLO MESA film 2 knife, film 2 couteau, film 2 coltello, film 2 messer | 1/0/48/1008/3024 | 48 | 224 | |
| M3435 MAZO 3 CUCHARA MESA film 3 table spoon, film 3 cuillère table, film 3 cucchio tavola, film 3 tafellöffel | 1/0/48/1200/3600 | 48 | 193 | 1,5 |
| M3970 MAZO 3 TENEDOR MESA film 3 table fork, film 3 fourchette table, film 3 forchetta tavola, film 3 tafelgabel | 1/0/48/1200/3600 | 48 | 190 | 1,8 |
| M4540 MAZO 6 TENEDOR LUNCH film 6 cake fork, film 6 fourchette gâteau, film 6 forchetta dolce, film 6 kuchengabel | 1/0/48/1152/4608 | 48 | 143 | 1,5 |
| M4541 MAZO 6 CUCHARA CAFÉ film 6 tea spoon, film 6 cuillère café, film 6 cucchio caffè, film 6 kaffeelöffel | 1/0/48/1152/4608 | 48 | 140 | 1,5 |
| M4542 MAZO 6 CUCHARA MOKA film 6 coffee/moka spoon, film 6 cuillère moka, film 6 cucchio moka, film 6 mokkalöffel | 1/0/48/1152/4608 | 48 | 120 | 1,2 |
| 0010 CORBATA 2 CUCHILLO MESA Tie 2 table knife, cavalier 2 couteau table, cravatta 2 coltello tavola, krawatte 2 tafelmesser | 1/4/48/672/2688 | 48 | 224 | |
| 3435 CORBATA 3 CUCHARA MESA Tie 3 table spoon, cavalier 3 cuillère table, cravatta 3 cucchio tavola, krawatte 3 takkelöffel | 1/4/48/672/2688 | 48 | 193 | 1,5 |
| 3970 CORBATA 3 TENEDOR MESA Tie 3 table fork, cavalier 3 fourchette table, cravatta 3 forchetta tavola, krawatte 3 tafelgabel | 1/4/48/672/2688 | 48 | 190 | 1,8 |
| 4540 CORBATA 6 TENEDOR LUNCH Tie 6 cake fork, cavalier 6 fourchette gâteau, cravatta 6 forchetta dolce, krawatte 6 kuchengabel | 1/4/48/672/2688 | 48 | 143 | 1,5 |
| 4541 CORBATA 6 CUCHARA CAFÉ Tie 6 tea spoon, cavalier 6 cuillère café, cravatta 6 cucchio caffè, krawatte 6 kaffeelöffel | 1/4/48/672/2688 | 48 | 140 | 1,5 |
| 4542 CORBATA 6 CUCHARA MOKA Tie 6 moka spoon, cavalier 6 cuillère moka, cravatta 6 cucchio moka, krawatte 6 mokkalöffel | 1/4/48/672/2688 | 48 | 120 | 1,2 |
| 2455 24 PIEZAS 24 pieces, écrin 24 pièces, bauletto 24 pz., 24 Stück | 1/0/4 | 4 | | 1,8 |

INOX STAINLESS STEEL 430

| | UE | MOQ | ▶ mm | ✂ mm |
|--|-----------------|-----|------|------|
| A 1934 CORBATA 2 CUCHILLO MESA Tie 2 table knife, cavalier 2 couteau table, cravatta 2 coltello tavola, krawatte 2 tafelmesser | 1/4/48/672/2688 | 48 | 224 | |
| B 3976 CORBATA 3 CUCHARA MESA Tie 3 table spoon, cavalier 3 cuillère table, cravatta 3 cucchio tavola, krawatte 3 takkelöffel | 1/4/48/672/2688 | 48 | 193 | 1,5 |
| C 3771 CORBATA 3 TENEDOR MESA Tie 3 table fork, cavalier 3 fourchette table, cravatta 3 forchetta tavola, krawatte 3 tafelgabel | 1/4/48/672/2688 | 48 | 190 | 1,8 |
| D 4539 CORBATA 6 TENEDOR LUNCH Tie 6 cake fork, cavalier 6 fourchette gâteau, cravatta 6 forchetta dolce, krawatte 6 kuchengabel | 1/4/48/672/2688 | 48 | 143 | 1,5 |
| E 2555 CORBATA 6 CUCHARA CAFÉ Tie 6 tea spoon, cavalier 6 cuillère café, cravatta 6 cucchio caffè, krawatte 6 kaffeelöffel | 1/4/48/672/2688 | 48 | 140 | 1,5 |
| F 4556 CORBATA 6 CUCHARA MOKA Tie 6 moka spoon, cavalier 6 cuillère moka, cravatta 6 cucchio moka, krawatte 6 mokkalöffel | 1/4/48/672/2688 | 48 | 120 | 1,2 |
| 2458 24 PIEZAS 24 pieces, écrin 24 pièces, bauletto 24 pz., 24 Stück | 1/0/4 | 4 | | 1,8 |

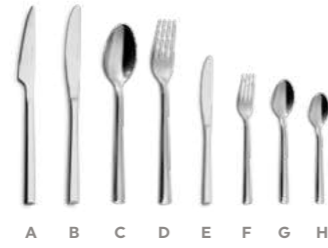

A B C D E F G H

INOX
STAINLESS
STEEL
430

| | | | | | | |
|---|--------------|---|---------------------|-----|-----|-----|
| A | 2454 | CUCHILLO CHULETERO steak knife, couteau steak, coltello bistecca, steakmesser | 0/12/120/1920/5760 | 120 | 225 | |
| B | 1613 | CUCHILLO MESA ECO table knife, couteau table, coltello tavola, tafelmesser | 0/12/120/1920/5760 | 120 | 225 | |
| C | 2816 | CUCHARA MESA table spoon, cuillère table, cucchiaio tavola, tafellöffel | 0/12/120/1440/7200 | 120 | 203 | 1,5 |
| D | 2817 | TENEDOR MESA table fork, fourchette table, forchetta tavola, tafelgabel | 0/12/120/1440/7200 | 120 | 208 | 2 |
| E | 0021 | CUCHILLO LUNCH cake knife, couteau gâteau, coltello dolce, kuchenmesser | 0/12/120/1920/5760 | 120 | 165 | |
| F | 1825 | TENEDOR LUNCH cake fork, fourchette gâteau, forchetta dolce, kuchengabel | 0/12/120/2520/15120 | 120 | 145 | 1,5 |
| G | 1826 | CUCHARA CAFÉ tea spoon, cuillère café, cucchiaio caffè, kaffeelöffel | 0/12/120/2520/15120 | 120 | 140 | 1,5 |
| H | 1827 | CUCHARA MOKA coffee/moka spoon, cuillère moka, cucchiaio moka, mokkalöffel | 0/12/120/2520/15120 | 120 | 125 | 1,5 |
| | M9332 | MAZO 2 CUCHILLO CHULETERO film 2 steak knife, film 2 couteau steak, film 2 coltello bistecca, film 2 steakmesser | 1/0/48/1008/3024 | 48 | 225 | |
| | 1612 | MAZO 2 CUCHILLO MESA ECO film 2 table knife eco, film 2 couteau table eco, film 2 coltello tavola eco, film 2 tafelmesser eco | 1/0/48/1008/3024 | 48 | 225 | |
| | 1607 | MAZO 3 CUCHARA MESA film 3 table spoon, film 3 cuillère table, film 3 cucchiaio tavola, film 3 tafellöffel | 1/0/48/1200/3600 | 48 | 205 | 1,5 |
| | 1608 | MAZO 3 TENEDOR MESA film 3 table fork, film 3 fourchette table, film 3 forchetta tavola, film 3 tafelgabel | 1/0/48/1200/3600 | 48 | 208 | 2 |
| | 1887 | MAZO 6 TENEDOR LUNCH film 6 cake fork, film 6 fourchette gâteau, film 6 forchetta dolce, film 6 kuchen-gabel | 1/0/48/1152/4608 | 48 | 145 | 1,5 |
| | 1610 | MAZO 6 CUCHARA CAFÉ film 6 tea spoon, film 6 cuillère café, film 6 cucchiaio caffè, film 6 kaffeelöffel | 1/0/48/1152/4608 | 48 | 140 | 1,5 |
| | 1611 | MAZO 6 CUCHARA MOKA film 6 coffee/moka spoon, film 6 cuillère moka, film 6 cucchiaio moka, film 6 mokkalöffel | 1/0/48/1152/4608 | 48 | 125 | 1,5 |
| | 2660 | CORBATA 2 CUCHILLO CHULETERO Tie 2 steak knife, cavalier 2 couteau steak, cravatta 2 coltello bistecca, krawatte 2 steakmesser | 1/4/48/672/2688 | 48 | 225 | |
| | 2509 | CORBATA 3 CUCHARA MESA Tie 3 table spoon, cavalier 3 cuillère table, cravatta 3 cucchiaio tavola, krawatte 3 takkelöffel | 1/4/48/672/2688 | 48 | 205 | 1,5 |
| | 2510 | CORBATA 3 TENEDOR MESA Tie 3 table fork, cavalier 3 fourchette table, cravatta 3 forchetta tavola, krawatte 3 tafelgabel | 1/4/48/672/2688 | 48 | 208 | 2 |
| | 1889 | CORBATA 6 TENEDOR LUNCH Tie 6 cake fork, cavalier 6 fourchette gâteau, cravatta 6 forchetta dolce, krawatte 6 kuchengabel | 1/4/48/672/2688 | 48 | 145 | 1,5 |
| | 2513 | CORBATA 6 CUCHARA CAFÉ Tie 6 tea spoon, cavalier 6 cuillère café, cravatta 6 cucchiaio caffè, krawatte 6 kaffeelöffel | 1/4/48/672/2688 | 48 | 140 | 1,5 |
| | 1890 | CORBATA 6 CUCHARA MOKA Tie 6 moka spoon, cavalier 6 cuillère moka, cravatta 6 cucchiaio moka, krawatte 6 mokkalöffel | 1/4/48/672/2688 | 48 | 125 | 1,5 |



2515 24 PIEZAS
24 pieces, écrin 24 pièces, bauletto 24 pz., 24 stück

UE 1/0/4 MOQ 4 \blacktriangleleft mm \blacktriangleright mm 2



Luna

INOX Nickel Free 18% / 1,8mm / Mirror

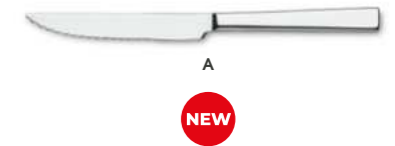
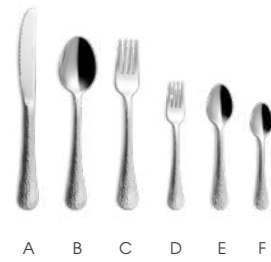

INOX STAINLESS STEEL 430

- A **7142** CUCHILLO MESA
table knife, couteau table, coltello tavola, tafelmesser
- B **7143** CUCHARA MESA
table spoon, cuillère table, cucchiaio tavola, tafellöffel
- C **7144** TENEDOR MESA
table fork, fourchette table, forchetta tavola, tafelgabel
- D **7145** TENEDOR LUNCH
cake fork, fourchette gâteau, forchetta dolce, kuchengabel
- E **7146** CUCHARA CAFÉ
tea spoon, cuillère café, cucchiaio caffè, kaffeelöffel
- F **7147** CUCHARA MOKA
coffee/moka spoon, cuillère moka, cucchiaio moka, mokkalöffel
- 7148** MAZO 2 CUCHILLO MESA
film 2 knife, film 2 couteau, film 2 coltello, film 2 messer
- 7149** MAZO 3 CUCHARA MESA
film 3 table spoon, film 3 cuillère table, film 3 cucchiaio tavola, film 3 tafellöffel
- 7150** MAZO 3 TENEDOR MESA
film 3 table fork, film 3 fourchette table, film 3 forchetta tavola, film 3 tafelgabel
- 7151** MAZO 6 TENEDOR LUNCH
film 6 cake fork, film 6 fourchette gâteau, film 6 forchetta dolce, film 6 kuchengabel
- 7152** MAZO 6 CUCHARA CAFÉ
film 6 tea spoon, film 6 cuillère café, film 6 cucchiaio caffè, film 6 kaffeelöffel
- 7153** MAZO 6 CUCHARA MOKA
film 6 coffee/moka spoon, film 6 cuillère moka, film 6 cucchiaio moka, film 6 mokkalöffel
- 7155** CORBATA 2 CUCHILLO MESA
Tie 2 table knife, cavalier 2 couteau table, cravatta 2 coltello tavola, krawatte 2 tafelmesser
- 7156** CORBATA 3 CUCHARA MESA
Tie 3 table spoon, cavalier 3 cuillère table, cravatta 3 cucchiaio tavola, krawatte 3 tafellöffel
- 7157** CORBATA 3 TENEDOR MESA
Tie 3 table fork, cavalier 3 fourchette table, cravatta 3 forchetta tavola, krawatte 3 tafelgabel
- 7158** CORBATA 6 TENEDOR LUNCH
Tie 6 cake fork, cavalier 6 fourchette gâteau, cravatta 6 forchetta dolce, krawatte 6 kuchengabel
- 7159** CORBATA 6 CUCHARA CAFÉ
Tie 6 tea spoon, cavalier 6 cuillère café, cravatta 6 cucchiaio caffè, krawatte 6 kaffeelöffel
- 7160** CORBATA 6 CUCHARA MOKA
Tie 6 moka spoon, cavalier 6 cuillère moka, cravatta 6 cucchiaio moka, krawatte 6 mokkalöffel
- 7154** 24 PIEZAS
24 pieces, écrin 24 pièces, bauletto 24 pz., 24 stück

UE MOQ mm X mm

| UE | MOQ | mm | X mm |
|---------------------|-----|-----|------|
| 0/12/120/1920/5760 | 120 | 224 | |
| 0/12/120/1440/7200 | 120 | 193 | 1,5 |
| 0/12/120/1440/7200 | 120 | 190 | 1,8 |
| 0/12/120/2520/15120 | 120 | 143 | 1,5 |
| 0/12/120/2520/15120 | 120 | 140 | 1,5 |
| 0/12/120/2520/15120 | 120 | 120 | 1,2 |
| 1/0/48/1008/3024 | 48 | 224 | |
| 1/0/48/1200/3600 | 48 | 193 | 1,5 |
| 1/0/48/1200/3600 | 48 | 190 | 1,8 |
| 1/0/48/1152/4608 | 48 | 143 | 1,5 |
| 1/0/48/1152/4608 | 48 | 140 | 1,5 |
| 1/0/48/1152/4608 | 48 | 120 | 1,2 |
| 1/4/48/672/2688 | 48 | 224 | |
| 1/4/48/672/2688 | 48 | 193 | 1,5 |
| 1/4/48/672/2688 | 48 | 190 | 1,8 |
| 1/4/48/672/2688 | 48 | 143 | 1,5 |
| 1/4/48/672/2688 | 48 | 140 | 1,5 |
| 1/4/48/672/2688 | 48 | 120 | 1,2 |
| 1/0/4 | 4 | | 1,8 |



INOX STAINLESS STEEL 430

- NEW** A **12006** CUCHILLO CHULETERO EUROPA
europa steak knife, couteau steakeuropa, coltello bistecca europa, steakmesser europa
- B **5497** CUCHILLO MESA MICRODENTADO
table knife, couteau table, coltello tavola, tafelmesser
- C **6320** CUCHARA MESA EUROPA XL
europa XL table spoon, europa XL cuillère table, cucchiaio tavola europa XL, tafellöffel europa XL
- D **6321** TENEDOR MESA EUROPA XL
europa XL table fork, europa XL fourchette table, forchetta tavola europa XL, tafelgabel europa XL
- E **2686** CUCHARA CAFÉ
tea spoon, cuillère café, cucchiaio caffè, kaffeelöffel

UE MOQ mm X mm

| UE | MOQ | mm | X mm |
|---------------------|-----|-----|------|
| 0/12/120/1920/5760 | 120 | 215 | |
| 0/12/120/1920/5760 | 120 | 214 | 2,5 |
| 0/12/120/1440/7200 | 120 | 195 | 2,5 |
| 0/12/120/1440/7200 | 120 | 195 | 1,5 |
| 0/12/120/2520/15120 | 120 | 140 | |



Hotel Extra M

INOX Nickel Free 18% / 2mm / Mirror



INOX
STAINLESS
STEEL
430

| | UE | MOQ | ▶ mm | ✕ mm |
|--|---------------------|-----|------|------|
| A 2454 CUCHILLO CHULETERO steak knife, couteau steak, coltello bistecca, steakmesser | 0/12/120/1920/5760 | 120 | 225 | |
| B 5497 CUCHILLO MESA MICRODENTADO table knife micro, couteau table micro, coltello tavola micro, tafelmesser micro | 0/12/120/1920/5760 | 120 | 215 | |
| C 0013 CUCHILLO MESA table knife, couteau table, coltello tavola, tafelmesser | 0/12/120/1920/5760 | 120 | 214 | |
| D 2679 CUCHARA MESA table spoon, cuillère table, cucchiaio tavola, tafellöffel | 0/12/120/1440/7200 | 120 | 195 | 2 |
| E 2680 TENEDOR MESA table fork, fourchette table, forchetta tavola, tafelgabel | 0/12/120/1440/7200 | 120 | 196 | 2 |
| F 2681 PALA PESCADO fish knife, couteau poisson, coltello pesce, fischmesser | 0/12/120/1440/7200 | 120 | 190 | 1,5 |
| G 2682 TENEDOR PESCADO fish fork, fourchette poisson, forchetta pesce, fischgabel | 0/12/120/1440/7200 | 120 | 180 | 1,5 |
| H 0018 CUCHILLO POSTRE dessert knife, couteau dessert, coltello frutta, dessertmesser | 0/12/120/1920/5760 | 120 | 190 | |
| I 2683 CUCHARA POSTRE dessert spoon, cuillère dessert, cucchiaio frutta, dessertlöffel | 0/12/120/1440/7200 | 120 | 177 | 1,5 |
| J 2684 TENEDOR POSTRE dessert fork, fourchette dessert, forchetta frutta, dessertgabel | 0/12/120/1440/7200 | 120 | 180 | 1,5 |
| K 0021 CUCHILLO LUNCH cake knife, couteau gâteau, coltello dolce, kuchenmesser | 0/12/120/1920/5760 | 120 | 165 | |
| L 2685 TENEDOR LUNCH cake fork, fourchette gâteau, forchetta dolce, kuchengabel | 0/12/120/2520/15120 | 120 | 150 | 1,5 |
| M 2686 CUCHARA CAFÉ tea spoon, cuillère café, cucchiaio caffè, kaffeelöffel | 0/12/120/2520/15120 | 120 | 140 | 1,5 |
| N 2687 CUCHARA MOKA coffee/moka spoon, cuillère moka, cucchiaio moka, mokkalöffel | 0/12/120/2520/15120 | 120 | 110 | 1,2 |
| O 2688 CUCHARA REFRESCO soda spoon, cuillère mazagran, cucchiaio bibita, longdrinklöffel | 0/12/120/1440/7200 | 120 | 205 | 1,5 |
| P 3092 CUCHARA HELADO ice cream spoon, cuillère à glace, cucchiaio gelato, eiscremelöffel | 0/12/120/1440/7200 | 120 | 132 | 1,2 |
| Q 2689 CAZO SOPA soup ladle, louche à potage, mestolo, suppenkelle | 1/10/50/150/750 | 10 | 270 | 2,6 |
| R 2690 CUCHARA ENSALADA salad spoon, cuillère à servir salade, cucchiaio servire, salatlöffel | 1/10/50/800/4000 | 10 | 230 | 2,8 |
| S 2691 TENEDOR ENSALADA salad fork, fourchette à servir salade, forchetta servire, salatgabel | 1/10/50/800/4000 | 10 | 235 | 2,6 |
| T 0031 PALA REPOSTERÍA cake server, pelle à tarte, pala torta, tortenheber | 1/10/50/600/2400 | 10 | 240 | 2,5 |
| U 5517 CAZO SALSA sauce ladle, cuillère à sauce, mestolino salsa, soßenkelle | 1/10/50/800/4000 | 10 | 170 | 2,5 |



Hotel Extra M

INOX Nickel Free 18% / 2mm / Mirror



INOX
STAINLESS
STEEL
430

| | | | | |
|--|------------------|----|-----|-----|
| M5206 MAZO 2 CUCHILLO MESA film 2 knife, film 2 couteau, film 2 coltello, film 2 messer | 1/0/48/1008/3024 | 48 | 215 | |
| M5202 MAZO 3 CUCHARA MESA film 3 table spoon, film 3 cuillère table, film 3 cucchiaio tavola, film 3 tafellöffel | 1/0/48/1200/3600 | 48 | 195 | 1,5 |
| M5203 MAZO 3 TENEDOR MESA film 3 table fork, film 3 fourchette table, film 3 forchetta tavola, film 3 tafelgabel | 1/0/48/1200/3600 | 48 | 196 | 2 |
| M3036 MAZO 6 TENEDOR LUNCH film 6 cake fork, film 6 fourchette gâteau, film 6 forchetta dolce, film 6 kuchengabel | 1/0/48/1152/4608 | 48 | 150 | 1,5 |
| M3037 MAZO 6 CUCHARA CAFÉ film 6 tea spoon, film 6 cuillère café, film 6 cucchiaio caffè, film 6 kaffeelöffel | 1/0/48/1152/4608 | 48 | 140 | 1,5 |
| M3038 MAZO 6 CUCHARA MOKA film 6 coffee/moka spoon, film 6 cuillère moka, film 6 cucchiaio moka, film 6 mokkalöffe | 1/0/48/1152/4608 | 48 | 110 | 1,2 |

| | UE | MOQ | ▶ mm | ✕ mm |
|--|----|-----|------|------|
| | | | | |



Hotel Extra Eco

INOX Nickel Free 18% / 1,5mm / Mirror

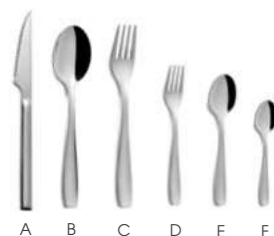

Hotel

INOX Nickel Free 18% / 1,5mm / Vibrado

INOX STAINLESS STEEL 430

| | UE | MOQ | ✂ mm | ✂ mm |
|--|---------------------|-----|------|------|
| A 2454 CUCHILLO CHULETERO steak knife, couteau steak, coltello bistecca, steakmesser | 0/12/120/1920/5760 | 120 | 225 | |
| B 8009 CUCHARA MESA ECO table spoon eco, cuillère table eco, cucchiaio tavola eco, tafellöffel eco | 0/12/120/1440/7200 | 120 | 195 | 1,5 |
| C 8010 TENEDOR MESA ECO table fork eco, fourchette table eco, forchetta tavola eco, tafelgabel eco | 0/12/120/1440/7200 | 120 | 196 | 1,5 |
| D 0940 TENEDOR LUNCH ECO cake fork eco, fourchette gâteau eco, forchetta dolce eco, kuchengabel eco | 0/12/120/2520/15120 | 120 | 150 | 1,2 |
| E 0941 CUCHARA CAFÉ ECO tea spoon eco, cuillère café eco, cucchiaio caffè eco, kaffeelöffel eco | 0/12/120/2520/15120 | 120 | 140 | 1,2 |
| F 0942 CUCHARA MOKA ECO coffee/moka spoon eco, cuillère moka eco, cucchiaio moka eco, mokkalöffel eco | 0/12/120/2520/15120 | 120 | 110 | 1 |
| 5206 CORBATA 2 CUCHILLO MESA MICRO Tie 2 steak knife micro, cavalier 2 couteau steak micro, cravatta 2 coltello bistecca micro, krawatte 2 steakmesser micro | 1/4/48/672/2688 | 48 | 215 | |
| 5202 CORBATA 3 CUCHARA MESA Tie 3 table spoon, cavalier 3 cuillère table, cravatta 3 cucchiaio tavola, krawatte 3 takkelöffel | 1/4/48/672/2688 | 48 | 195 | 1,5 |
| 5203 CORBATA 3 TENEDOR MESA Tie 3 table fork, cavalier 3 fourchette table, cravatta 3 forchetta tavola, krawatte 3 tafelgabel | 1/4/48/672/2688 | 48 | 196 | 1,5 |
| 3036 CORBATA 6 TENEDOR LUNCH Tie 6 cake fork, cavalier 6 fourchette gâteau, cravatta 6 forchetta dolce, krawatte 6 kuchengabel | 1/4/48/672/2688 | 48 | 150 | 1,5 |
| 3037 CORBATA 6 CUCHARA CAFÉ Tie 6 tea spoon, cavalier 6 cuillère café, cravatta 6 cucchiaio caffè, krawatte 6 kaffeelöffel | 1/4/48/672/2688 | 48 | 140 | 1,5 |
| 3038 CORBATA 6 CUCHARA MOKA Tie 6 moka spoon, cavalier 6 cuillère moka, cravatta 6 cucchiaio moka, krawatte 6 mokkalöffel | 1/4/48/672/2688 | 48 | 110 | 1,2 |



INOX STAINLESS STEEL 430

| | UE | MOQ | ✂ mm | ✂ mm |
|--|---------------------|-----|------|------|
| A 2454 CUCHILLO CHULETERO steak knife, couteau steak, coltello bistecca, steakmesser | 0/12/120/1920/5760 | 120 | 225 | |
| B 5497 CUCHILLO MESA MICRODENTADO table knife micro, couteau table micro, coltello tavola micro, tafelmesser micro | 0/12/120/1920/5760 | 120 | 215 | |
| C 0013 CUCHILLO MESA table knife, couteau table, coltello tavola, tafelmesser | 0/12/120/1920/5760 | 120 | 214 | |
| D 0014 CUCHARA MESA table spoon, cuillère table, cucchiaio tavola, tafellöffel | 0/12/120/1440/7200 | 120 | 195 | 1,5 |
| E 0015 TENEDOR MESA table fork, fourchette table, forchetta tavola, tafelgabel | 0/12/120/1440/7200 | 120 | 197 | 1,5 |
| F 0018 CUCHILLO POSTRE dessert knife, couteau dessert, coltello frutta, dessertmesser | 0/12/120/1920/5760 | 120 | 190 | |
| G 0019 CUCHARA POSTRE dessert spoon, cuillère dessert, cucchiaio frutta, dessertlöffel | 0/12/120/1440/7200 | 120 | 177 | 1,5 |
| H 0020 TENEDOR POSTRE dessert fork, fourchette dessert, forchetta frutta, dessertgabel | 0/12/120/1440/7200 | 120 | 178 | 1,5 |
| I 0021 CUCHILLO LUNCH cake knife, couteau gâteau, coltello dolce, kuchenmesser | 0/12/120/1920/5760 | 120 | 165 | |
| J 0022 TENEDOR LUNCH cake fork, fourchette gâteau, forchetta dolce, kuchengabel | 0/12/120/2520/15120 | 120 | 150 | 1,2 |
| K 0023 CUCHARA CAFÉ tea spoon, cuillère café, cucchiaio caffè, kaffeelöffel | 0/12/120/2520/15120 | 120 | 140 | 1,2 |
| L 0024 CUCHARA MOKA coffee/moka spoon, cuillère moka, cucchiaio moka, mokkalöffel | 0/12/120/2520/15120 | 120 | 110 | 1 |
| M 0033 CUCHARA REFRESCO soda spoon, cuillère mazagan, cucchiaio bibita, longdrinklöffel | 0/12/120/1440/72008 | 120 | 205 | 1,5 |



Brooklyn

INOX Nickel Free 18% / 0,6mm / Vibrado



* Bolsa con apertura lateral.
Side-opening bag



* Bolsa con apertura lateral.
Side-opening bag



INOX
STAINLESS
STEEL
430



INOX
STAINLESS
STEEL
430

- A **8334** CUCHILLO MESA
table knife, couteau table, coltello tavola, tafelmesser
- B **8335** CUCHARA MESA
table spoon, cuillère table, cucchiaio tavola, tafellöffel
- C **8336** TENEDOR MESA
table fork, fourchette table, forchetta tavola, tafelgabel
- D **8337** CUCHARA CAFÉ
tea spoon, cuillère café, cucchiaio caffè, kaffeelöffel
- 8338** KIT 4 PCS CUCHILLO, TENEDOR, CUCHARA Y SERVILLETA
set table knife/fork/spoon + napkin
set couteau table/cuillère table/fourchette table + serviette
set coltello tavola/cucchiaio tavola /forchetta tavola + tovagliolo
set tafelmesser/tafellöffel/tafelgabel + serviette
- 5254** KIT CUCHARA HELADO Y SERVILLETA
set ice cream spoon + napkin
set cuillère café + serviette
set cucchiaio caffè + tovagliolo
set kaffeelöffel + serviette
- 8184** KIT 4 PCS CUCHILLO, TENEDOR, CUCHARA CAFÉ Y SERVILLETA
set table knife/fork/tea spoon + napkin
set couteau table/cuillère café/fourchette table + serviette
set coltello tavola/cucchiaio caffè /forchetta tavola + tovagliolo
set tafelmesser/kaffeelöffel/tafelgabel + serviette

| UE | MOQ | ✂ mm | ✂ mm |
|---------------------|-----|------|------|
| 0/12/360/7200/14400 | 360 | 185 | 0,6 |
| 0/12/360/7200/14400 | 360 | 170 | 0,6 |
| 0/12/360/7200/14400 | 360 | 170 | 0,6 |
| 0/12/600/7200/36000 | 600 | 120 | 0,6 |
| 1/0/120/0/0 | 120 | | 0,6 |



PP
POLYPROPYLENE

Take Away



* Los cubiertos no van incluidos
Cutlery is not included

8373 CAJA POLIPROPILENO
pp case, boîte pp, scatola pp, box pp

| UE | MOQ | Lmm | Wmm |
|---------------------|-----|-----|-----|
| 1-0-120-480-960 / 6 | 6 | 235 | 32 |



INOX STAINLESS STEEL 430

| | UE | MOQ | ▶ mm | ✂ mm |
|---|----------------------|-----|------|------|
| A 1489 CUCHILLO MESA table knife, couteau table, coltello tavola, tafelmesser | 0/12/120/1920/5760 | 120 | 210 | |
| B 0001 CUCHARA MESA table spoon, cuillère table, cucchiaio tavola, tafellöffel | 0/12/360/7200/14400 | 360 | 200 | 1,5 |
| C 0002 TENEDOR MESA table fork, fourchette table, forchetta tavola, tafelgabel | 0/12/360/7200/14400 | 360 | 200 | 1,5 |
| D 0009 CUCHILLO POSTRE dessert knife, couteau dessert, coltello frutta, dessertmesser | 0/12/120/1920/5760 | 120 | 190 | |
| E 0003 CUCHARA CADETE dessert spoon, cuillère dessert, cucchiaio frutta, dessertlöffel | 0/12/360/8640/17280 | 360 | 185 | 1,2 |
| F 0004 TENEDOR CADETE dessert fork, fourchette dessert, forchetta frutta, dessertgabel | 0/12/360/10800/21600 | 360 | 185 | 1,2 |
| G 0005 TENEDOR LUNCH cake fork, fourchette gâteau, forchetta dolce, kuchengabel | 0/12/600/16800/50400 | 600 | 140 | 1,2 |
| H 4504 TENEDOR MINI LUNCH mini cake fork, fourchette minigâteau, forchetta mini dolce, kuchengabel klein | 0/12/600/25200/75600 | 600 | 110 | 1 |
| I 1664 CUCHARA CAFÉ REFORZADA tea spoon reinf., cuillère café renforcé, cucchiaio caffè rforzatta, kaffeelöffel verstärkt | 0/12/600/12000/36000 | 600 | 140 | 1,2 |
| J 0006 CUCHARA CAFÉ tea spoon, cuillère café, cucchiaio caffè, kaffeelöffel | 0/12/600/12000/36000 | 600 | 140 | 1 |
| K 2731 CUCHARA CAFÉ ECO tea spoon eco, cuillère café eco, cucchiaio caffè eco, kaffeelöffel eco | 0/12/600/12000/36000 | 600 | 140 | 1 |
| L 0007 CUCHARA MOKA coffee/moka spoon, cuillère moka, cucchiaio moka, mokkalöffel | 0/12/600/25200/75600 | 600 | 110 | 1 |
| 2459 2 CUCHARA MESA 2 table spoon, 2 cuillère table, 2 cucchiaio tavola, 2 tafellöffel | 2/18/270/5400/10800 | 270 | 185 | 1,2 |
| 2460 2 TENEDOR MESA 2 table fork, 2 fourchette table, 2 forchetta tavola, 2 tafelgabel | 2/18/270/5400/10800 | 270 | 185 | 1,2 |
| 2461 4 TENEDOR PASTEL 4 cake fork, 4 fourchette gâteau, 4 forchetta dolce, 4 kuchengabel | 2/18/270/5400/10800 | 270 | 140 | 1,2 |
| 2462 4 CUCHARA CAFÉ 4 tea spoon, 4 cuillère café, 4 cucchiaio caffè, 4 kaffeelöffel | 2/18/270/5400/10800 | 270 | 140 | 1 |
| 2463 4 CUCHARA MOKA 4 coffee/moka spoon, 4 cuillère moka, 4 cucchiaio moka, 4 mokkalöffel | 4/18/270/6750/13500 | 270 | 110 | 1 |



INOX STAINLESS STEEL 430

| | UE | MOQ | ▶ mm | ✂ mm |
|---|----------------------|-----|------|------|
| A 0481 CUCHILLO MESA table knife, couteau table, coltello tavola, tafelmesser | 0/12/240/6000/18000 | 240 | 220 | 2,5 |
| B 3185 CUCHARA MESA table spoon, cuillère table, cucchiaio tavola, tafellöffel | 0/12/360/7200/14400 | 360 | 200 | 1,5 |
| C 3186 TENEDOR MESA table fork, fourchette table, forchetta tavola, tafelgabel | 0/12/360/10440/20880 | 360 | 200 | 1,5 |
| D 3187 CUCHARA POSTRE dessert spoon, cuillère dessert, cucchiaio frutta, dessertlöffel | 0/12/360/10800/21600 | 360 | 170 | 1,5 |
| H 3188 TENEDOR POSTRE dessert fork, fourchette dessert, forchetta frutta, dessertgabel | 0/12/360/10800/21600 | 360 | 170 | 1,5 |
| F 3189 TENEDOR LUNCH cake fork, fourchette gâteau, forchetta dolce, kuchengabel | 0/12/600/16800/50400 | 600 | 133 | 1,2 |
| G 3190 CUCHARA CAFÉ tea spoon, cuillère café, cucchiaio caffè, kaffeelöffel | 0/12/600/12000/36000 | 600 | 133 | 1,2 |
| H 3191 CUCHARA MOKA coffee/moka spoon, cuillère moka, cucchiaio moka, mokkalöffel | 0/12/600/25200/75600 | 600 | 110 | 1 |
| 4571 2 CUCHILLO MESA ECO 2 table knife eco, 2 couteau table eco, 2 coltello tavola eco, 2 tafelmesser eco | 0/18/270/3240/6480 | 270 | 220 | |
| 3192 3 CUCHARA MESA 3 table spoon, 3 cuillère table, 3 cucchiaio tavola, 3 tafellöffel | 0/12/180/2700/5400 | 180 | 170 | 1,5 |
| 3193 3 TENEDOR MESA 3 table fork, 3 fourchette table, 3 forchetta tavola, 3 tafelgabel | 0/12/180/3600/7200 | 180 | 170 | 1,5 |
| 3194 6 TENEDOR PASTEL 6 cake fork, 6 fourchette gâteau, 6 forchetta dolce, 6 kuchengabel | 0/12/180/3600/7200 | 180 | 133 | 1,2 |
| 3195 6 CUCHARA CAFÉ 6 tea spoon, 6 cuillère café, 6 cucchiaio caffè, 6 kaffeelöffel | 0/12/180/3600/7200 | 180 | 133 | 1,2 |
| 3196 6 CUCHARA MOKA 6 coffee/moka spoon, 6 cuillère moka, 6 cucchiaio moka, 6 mokkalöffel | 0/12/180/3600/10800 | 180 | 110 | 1 |



1003

INOX Nickel Free 18% / 1,2mm / Vibrado



Nervio

INOX Nickel Free 18% / 1,2mm / Vibrado

INOX STAINLESS STEEL 430

- A **0278** 3 CUCHARA MESA
3 table spoon, 3 cuillère table, 3 cucchiaino tavola, 3 tafellöffel
- B **0279** 3 TENEDOR MESA
3 table fork, 3 fourchette table, 3 forchetta tavola, 3 tafelgabel
- C **0280** 6 TENEDOR PASTEL
6 cake fork, 6 fourchette gâteau, 6 forchetta dolce, 6 kuchengabel
- D **0281** 6 CUCHARA CAFÉ
6 tea spoon, 6 cuillère café, 6 cucchiaino caffè, 6 kaffeelöffel
- E **0282** 6 CUCHARA MOKA
6 coffee/moka spoon, 6 cuillère moka, 6 cucchiaino moka, 6 mokkalöffel

| UE | MOQ | ▶ mm | ✂ mm |
|--------------------|-----|------|------|
| 3/12/180/3600/7200 | 180 | 185 | 1,2 |
| 3/12/180/3600/7200 | 180 | 185 | 1,2 |
| 6/12/180/3600/7200 | 180 | 140 | 1,2 |
| 6/12/180/3600/7200 | 180 | 140 | 1 |
| 6/12/180/4500/9000 | 180 | 110 | 1 |



INOX STAINLESS STEEL 430

- A **6338** 6 CUCHARA CAFÉ
6 tea spoon, 6 cuillère café, 6 cucchiaino caffè, 6 kaffeelöffel
- B **6339** 6 CUCHARA MOKA
6 coffee/moka spoon, 6 cuillère moka, 6 cucchiaino moka, 6 mokkalöffel

| UE | MOQ | ▶ mm | ✂ mm |
|----------------------|-----|------|------|
| 0/60/600/16800/50400 | 600 | 120 | 1 |
| 0/60/600/25200/75600 | 600 | 102 | 1 |

INOX STAINLESS STEEL 430

- A **3618** CUCHILLO MESA
table knife, couteau table, coltello tavola, tafelmesser
- B **3548** 3 CUCHARA MESA
3 table spoon, 3 cuillère table, 3 cucchiaino tavola, 3 tafellöffel
- C **3549** 3 TENEDOR MESA
3 table fork, 3 fourchette table, 3 forchetta tavola, 3 tafelgabel
- D **3550** 6 TENEDOR PASTEL
6 cake fork, 6 fourchette gâteau, 6 forchetta dolce, 6 kuchengabel
- E **3551** 6 CUCHARA CAFÉ
6 tea spoon, 6 cuillère café, 6 cucchiaino caffè, 6 kaffeelöffel
- F **3552** 6 CUCHARA MOKA
6 coffee/moka spoon, 6 cuillère moka, 6 cucchiaino moka, 6 mokkalöffel

| UE | MOQ | ▶ mm | ✂ mm |
|--------------------|-----|------|------|
| 0/12/120/1920/5760 | 120 | 224 | |
| 3/12/180/3600/7200 | 180 | 185 | 1,2 |
| 3/12/180/3600/7200 | 180 | 185 | 1,2 |
| 6/12/180/3600/7200 | 180 | 140 | 1 |
| 6/12/180/3600/7200 | 180 | 140 | 1 |
| 6/12/180/4500/9600 | 180 | 110 | 1 |



INOX STAINLESS STEEL 430

- 5651** CORBATA 6 CUCHARA APERITIVO
6 aperitive spoon, 6 aperitive cuillière, 6 aperitive spoon, 6 aperitive spoon



INOX STAINLESS STEEL 430

- 0669** CUCHARA DEGUSTACIÓN PELLE
pelle aperitive spoon, cuillère degustation pelle, cucchiaino degustazione, pelle aperitivlöffel

| UE | MOQ | ▶ mm | ✂ mm |
|---------------------|-----|------|------|
| 1/4/48/720/3600 | 48 | 108 | 1,5 |
| 0/12/120/9600/38400 | 120 | 123 | 1,3 |

CHULETEROS

STEAK KNIVES



CHULETEROS

STEAK KNIVES

- 178 KAJI
- 182 MEZZA
- 184 EVEREST
- 186 OLIU
- 188 SILEX
- 190 MAGNOLIA
- 192 HQ: 5Cr15Mov
- 194 HQ
- 204 UTSET + COMAS
- 208 INOX
- 209 NAPOLI PIZZA
- 210 ECO

Diseño moderno con alma de tradición japonesa.
Modern design with Japanese tradition.



Inspirado en los cuchillos japoneses Kiritsuke, Kaji es una pieza de diseño único. Su hoja con acabado damasco revela el saber hacer artesanal con líneas ligeramente curvadas para un corte preciso. El mango, de madera maciza con un toque de color, reinterpreta los mangos octogonales tradicionales para la mesa moderna, ofreciendo ergonomía y equilibrio perfectos.

Le acompaña un tenedor con dos puntas y mango simétrico, completando un conjunto icónico y exclusivo. El Nombre Kaji significa "forja" o "fuego" en japonés, refleja el proceso meticuloso de creación de esta pieza única.

Inspired by the Japanese Kiritsuke knives, Kaji is a unique piece of design. Its damask-finished blade reveals the craftsman's know-how with slightly curved lines for a precise cut. The handle, solid wood with a touch of colour, reinterprets traditional octagonal handles for the modern table, offering perfect ergonomics and balance.

It is accompanied by a fork with two prongs and a symmetrical handle, completing an iconic and exclusive set. The name Kaji means 'forge' or 'fire' in Japanese, reflecting the meticulous process of creating this unique piece.

Proyecto diseñado por:
Project designed by:

Bahigüell



NEW

Proyecto diseñado por:
Project designed by:

Bahigüell

INOX 18/10 / Mirror & Satin



Recomendado lavar a mano
Hand washing recommended



33 CAPAS ACERO 316L
33 LAYERS 316L STEEL

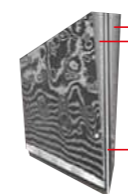

NÚCLEO ACERO VG1
VG10 STEEL CORE



D



A



B



C



SATIN

DAMASCUS 67 LAYERS / VG10 STEEL CORE



A



B



C

UE MOQ ▶ mm ✕ mm

| | UE | MOQ | ▶ mm | ✕ mm |
|--|--------|-----|------|------|
| A 10997 CUCHILLO CHULETERO KAJI kaji steak knife, couteau steak kaji, coltello bistecca kaji, steakmesser kaji | 1/6/30 | 6 | 232 | |
| B 11942 TENEDOR CHULETERO KAJI MIRROR kaji steak fork, fourchette steak kaji, forchetta bistecca kaji, steakgabel kaji | 0/6/60 | 60 | 210 | 6 |
| C 12000 TENEDOR CHULETERO KAJI SATIN kaji steak fork, fourchette steak kaji, forchetta bistecca kaji, steakgabel kaji | 0/6/60 | 60 | 210 | 6 |
| D 12001 ESTUCHE CON CUCHILLO Y TENEDOR KAJI kaji steak knife and fork case, étui à couteau steak et fourchette kaji, astuccio per coltello e forchetta kaji, kaji steakmesser und gabel etui | 1/6/36 | 6 | | |

Mezza

NEW



Proyecto diseñado por:
Project designed by:

Shu Hon Leung Andy

Mezza

INOX 18/10 / Bimaterial



Recomendado lavar a mano
Hand washing recommended



MIKARTA:

Material compuesto hecho a base de capas de tejidos, impregnadas con resina y prensadas. Curadas bajo alta presión y temperatura.

Composite material made of layers of fabrics, impregnated with resin and pressed. Cured under high pressure and temperature.



A B
FRONTAL INOX



REVERSO MIKARTA

MEZZA es mucho más que un juego de mesa para carne. Fusiona tradición, diseño moderno y artesanía impecable. En la cultura gastronómica italiana, Mezza se utiliza a menudo para describir una pequeña porción de aperitivos o bebidas. Representa una experiencia gastronómica relajada y agradable, que permite disfrutar de deliciosa comida y pasar un buen rato con la familia y los amigos.

MEZZA is much more than a meat table set. Fusion of tradition, modern design and impeccable craftsmanship. In Italian dining culture, Mezza is often used to describe a small portion of appetizers or drinks. It represents a relaxed and enjoyable dining experience, allowing you to enjoy delicious food and have a good time with family and friends.

INOX 18/10/ BIMATERIAL



A B

INOX
STAINLESS
STEEL
304

- A **12017** CUCHILLO CHULETERO MEZZA
mezza steak knife, couteau steak mezza, coltello bistecca mezza, steakmesser mezza
- B **12018** TENEDOR CHULETERO MEZZA
mezza steak fork, fourchette steak mezza, forchetta bistecca mezza, steakgabel mezza
- 12019** CAJA PRESENTACIÓN CON 2 CUCHILLOS Y 2 TENEDORES MEZZA
box with 2 mezza knives and 2 forks, boîte avec 2 couteaux et 2 fourchettes mezza, scatola con 2 coltelli e 2 forchette mezza, box mit 2 mezzamessen und 2 gaben

| UE | MOQ | ✂ mm | ✂ mm |
|--------|-----|------|------|
| 0/6/60 | 60 | 237 | 4 |
| 0/6/60 | 60 | 210 | 3,5 |
| 1/0/12 | 12 | | |



Proyecto diseñado por:
Project designed by:

Pablo Castillo

INOX 18/10 / Mirror & Polvo de Luna

Everest surge como un conjunto bipieza de inspiración japonesa pero que a su vez combina en armonía con nuestra colección Atlántida para complementarla y ofrecer una opción más para los platos de carne.

Everest is a Japanese-inspired two-piece set that combines with harmony with our Atlántida collection to complement it and offer another option for meat dishes.



INOX 18/10 / Mirror & Satin

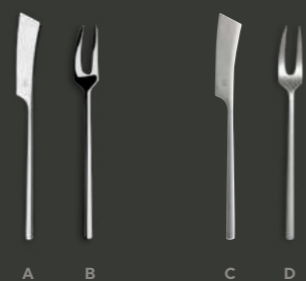

- A **11582** CUCHILLO CHULETERO EVEREST MIRROR
steak knife, couteau steak, coltello bistecca, steakmesser
- B **11583** TENEDOR CHULETERO EVEREST MIRROR
steak fork, fourchette steak, forchetta bistecca, steakgabel
- C **10988** CUCHILLO CHULETERO EVEREST P. DE LUNA
steak knife, couteau steak, coltello bistecca, steakmesser
- D **10989** TENEDOR CHULETERO EVEREST P. DE LUNA
steak fork, fourchette steak, forchetta bistecca, steakgabel

| UE | MOQ | mm | mm |
|-----------------|-----|-----|----|
| 0/6/60/540/2160 | 60 | 220 | |
| 0/6/60/540/2160 | 60 | 206 | |
| 0/6/60/540/2160 | 60 | 220 | |
| 0/6/60/540/2160 | 60 | 206 | |



Proyecto
OLIU.

Proyecto diseñado por:
Project designed by:

Silvia Rodríguez Petit
Liam Kelly Ortiz
Erik Obermüller Vilor
Albert Sadurní Roca

ELISAVA Escuela Universitaria de Barcelona Diseño e Ingeniería

Uno de los proyectos troncales que se desarrollaron en la 18a edición del Master en Diseño y Desarrollo de Producto, fue el proyecto que Comas propuso a los alumnos del Master. El reto consistió en diseñar y desarrollar un cuchillo icónico que pudiera complementar algunas de las colecciones actuales de nuestro catálogo.

Los 26 alumnos del Master, repartidos en 5 grupos, en la 1a fase conceptual presentaron 26 propuestas de diseño de nuevos cuchillos, de los cuales desarrollaron 12 propuestas con todo detalle y llegaron a un prototipo volumétrico de calidad, siguiendo las indicaciones de la empresa.

One of the core projects developed in the 18th edition of the Master's Degree in Product Design and Development was the project that Comas proposed to the Master's students. The challenge consisted of designing and developing an iconic knife that could complement some of the current collections in our catalogue.

The 26 Master's students, divided into 5 groups, presented 26 design proposals for new knives in the 1st conceptual phase, of which they developed 12 proposals in detail and reached a quality volumetric prototype, following the indications of the company.



INOX 18/10 / Mirror



10994 CUCHILLO CHULETERO OLIU
oliu steak knife, couteau steak oliu, Coltello bistecca oliu, oliu steakmesser

UE 0/6/60/540/2160
MOQ 60 **mm** 226

Proyecto en colaboración con:



INOX 18/10 / Satin



A B



INOX
STAINLESS
STEEL
420



INOX
STAINLESS
STEEL
304



BAMBOO
WOOD

| | UE | MOQ | mm | mm |
|--|----------------|-----|-----|----|
| A 6318 CUCHILLO CHULETERO SILEX silex steak knife, couteau steak silex, coltello bistecca silex, steakmesser silex | 1/0/20/130/390 | 20 | 185 | |
| B 6319 TENEDOR CHULETERO SILEX silex steak fork, fourchette steak silex, forchetta bistecca silex, steakgabel silex | 1/0/20/130/390 | 20 | 185 | |
| 6322 CUCHILLO + TENEDOR SILEX silex knife + fork, couteau + fourchette silex, coltello + forchetta silex, silex messer + gabel | 1/0/8/72/216 | 8 | | |



Magnolia

Proyecto diseñado por:
Project designed by:

Lúcid Design Agency



INOX 18/10 / 9mm / PVD Negro / Mirror



A B

190

Proyecto diseñado por:
Project designed by:

Lúcid Design Agency



reddot design award
winner 2018

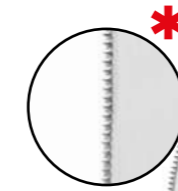

INOX
STAINLESS
STEEL
420



INOX
STAINLESS
STEEL
304



* Compatible con:
5207 / 5208

- A **6445** CUCHILLO CHULETERO K9 MAGNOLIA SIERRA
k9 magnolia steak knife, couteau steak k9 magnolia saw, coltello bistecca sega k9
magnolia scie, steakmesser k9 magnolia sâge
- B **6446** TENEDOR CHULETERO K9 MAGNOLIA
k9 magnolia steak fork, fourchette steak k9 magnolia, forchetta bistecca k9
magnolia, steakgabel k9 magnolia

| UE | MOQ | mm | mm |
|-----------------|-----|-----|----|
| 0/6/60/720/3600 | 6 | 226 | |
| 0/6/60/720/3600 | 6 | 203 | 9 |



191

5CR15Mov

Acero de gran dureza
High hardness steel



¿Eres un amante de la carne? Si es así, deberías utilizar cuchillos con un acero de gran calidad y un buen afilado para que el corte de la carne sea fácil y limpio. Y es que con un buen cuchillo se puede disfrutar al máximo de un delicioso trozo de carne.

Are you a meat lover? If so, you should use knives with high quality steel and a good sharpening to make cutting meat easy and clean. With a good knife, you can enjoy a delicious piece of meat to the full.

ACERO DE
GRAN DUREZA
HIGH
HARDNESS
STEEL



CUCHILLO CHULETERO ANETO MIKARTA



* Caja 6 chuleteros.



* Compatible con estuches acacia: 5207 / 5208

| | UE | MOQ | ✂ mm |
|---|-----------------|-----|------|
| A 8508 CUCHILLO CHULETERO ANETO MIKARTA aneto mikarta steak knife, couteau steak aneto mikarta, coltello bistecca aneto mikarta, steakmesser aneto mikarta | 0/6/60/720/2880 | 60 | 223 |
| B 7532 CUCHILLO CHULETERO ANETO aneto steak knife, couteau steak aneto, coltello bistecca aneto, steakmesser aneto | 0/6/60/720/2880 | 60 | 223 |
| C 3013 CHULETERO ALPS FILO alps filo steak knife, couteau steak alps filo, coltello bistecca alps filo, steakmesser alps filo | 0/6/60/720/3600 | 60 | 230 |
| * 6887 6 PCS MADERA ALPS FILO alps filo steak knife 6 pieces wood, écrin bois 6 couteaux alps filo, 6 pz legno alps filo, 6- teilige holz-untersetzer alps filo | 1/6/78/234 | 6 | 230 |
| D 7068 CUCHILLO CHULETERO MONTBLANC montblanc steak knife, couteau steak montblanc, coltello bistecca montblanc, steakmesser montblanc | 6/60/720/3600 | 60 | 230 |
| * 5285 6 PCS MADERA MONTBLANC montblanc steak knife 6 pieces wood, écrin bois 6 couteaux montblanc, 6 pz legno montblanc, 6- teilige holz-untersetzer montblanc | 1/6/78/234 | 6 | 230 |
| E 8595 CUCHILLO CHULETERO MONTBLANC NEGRO montblanc black steak knife, couteau steak montblanc black, coltello bistecca montblanc black, steak messer montblanc black | 6/60/720/3600 | 60 | 230 |
| F 10972 CUCHILLO ABREOSTRAS oyster knife, couteau à huîtres, aprostriche, austernmesser | 0/6/60/540/2160 | 60 | 160 |



HQ: 5Cr15Mov

El acero 5CR15Mov tiene una baja porción de carbono lo que lo hace un material de gran dureza, por lo que el filo conserva más tiempo la capacidad de corte.

Además, ofrece una gran resistencia a la corrosión con más del 15% de cromo.

5CR15Mov steel has a low carbon content which makes it a very hard material, so the cutting edge retains its cutting ability for a longer period of time.

In addition, it offers high corrosion resistance with more than 15% chromium.

ALTA DUREZA
HIGH HARDNESS  5Cr15Mov





CUCHILLO CHULETERO ALPS



* Caja 6 chuleteros.



* Compatible con estuches acacia: 5207 / 5208

| | UE | MOQ | mm |
|---|-----------------|-----|-----|
| A 10971 CUCHILLO CHULETERO DENALI denali steak knife, couteau steak denali, coltello bistecca denali, denali steakmesser | 0/6/60/540/2160 | 60 | 225 |
| B 3000 CHULETERO ALPS alps steak knife, couteau steak alps, coltello bistecca alps, steakmesser alps | 0/6/60/720/3600 | 60 | 230 |
| * 5286 6 PCS MADERA ALPS alps steak knife 6 pieces wood, écrin bois 6 couteaux alps, 6 pz legno alps, 6-teilige holz-untersetzer alps | 1/6/78/234 | 6 | 230 |
| C 6162 TENEDOR CHULETERO ALPS alps steak fork, fourchette steak alps, forchetta bistecca alps, steakgabel alps | 0/6/60/720/3600 | 60 | 227 |
| * 6334 6 PCS MADERA TENEDOR ALPS alps fork 6 pieces wood, écrin 6 pièces fourchette alps, bauletto in legno 6 pz. forchetta alps, gabel 6 stück holz alps | 1/6/78/234 | 6 | 227 |
| D 10973 CUCHILLO CHULETERO MINI ALPS alps mini steak knife, couteau steak alps mini, coltello bistecca alps mini, steakmesser alps mini | 0/6/60/540/2160 | 60 | 190 |
| E 10974 TENEDOR CHULETERO MINI ALPS alps mini steak fork, fourchette steak alps mini, forchetta bistecca alps mini, steakgabel alps mini | 0/6/60/540/2160 | 60 | 175 |
| F 3001 CHULETERO NICOLAS nicolas steak knife, couteau steak nicolas, coltello bistecca nicolas, steakmesser nicolas | 0/6/60/720/3600 | 60 | 230 |
| * 5280 6 PCS MADERA NICOLAS nicolas 6 pieces wood, écrin 6 pièces nicolas, bauletto in legno 6 pz. nicolas, | 1/6/78/234 | 6 | 230 |
| G 3137 CHULETERO K2 NEGRO k2 black steak knife, couteau steak k2 noir, coltello bistecca k2 nero, steakmesser k2 schwarz | 0/6/60/720/3600 | 60 | 225 |
| * 5278 6 PCS MADERA K2 NEGRO k2 black 6 pieces wood, écrin 6 pièces k2 noir, bauletto in legno 6 pz. k2 nero, k2 schwarz 6 stück holz | 1/6/78/234 | 6 | 225 |
| H 3136 CHULETERO K2 k2 steak knife, couteau steak k2, coltello bistecca k2, steakmesser k2 | 0/6/60/720/3600 | 60 | 225 |
| * 5287 6 PCS MADERA K2 k2 6 pieces wood, écrin 6 pièces k2, bauletto in legno 6 pz. k2, k2 6 stück holz | 1/6/78/234 | 6 | 225 |





CUCHILLO CHULETERO K6 - BOJ SATIN GOLD



* Caja 6 chuleteros.

INOX
STAINLESS
STEEL
420



NEW

A
B
C
D
E
F
G
H
I
J

NEW

- A **12006** CUCHILLO CHULETERO EUROPA
europa steak knife, couteau steakeuropa, coltello bistecca europa, steakmesser europa
- B **11584** CUCHILLO CHULETERO SANTORINI
santorini steak knife, couteau steak santorini, coltello bistecca santorini, steakmesser santorini
- C **6161** CUCHILLO CHULETERO GEOMETRIC
geometric steak knife, couteau steak geometric, coltello bistecca geometric, steakmesser geometric
- * **6333** 6 PCS MADERA GEOMETRIC
geometric 6 pieces wood, écrin 6 pièces geometric, bauletto in legno 6 pz. geometric, geometric 6 stück holz
- D **3107** CUCHILLO CHULETERO SUTIL
sutil steak knife, couteau steak sutil, coltello bistecca sutil, sutil steakmesser
- * **5277** 6 PCS MADERA SUTIL
sutil 6 pieces wood, écrin 6 pièces sutil, bauletto in legno 6 pz. sutil, sutil 6 stück holz
- E **2818** CUCHILLO CHULETERO RAMBO
rambo steak knife, couteau steak rambo, coltello bistecca rambo, rambo steakmesser
- * **5288** 6 PCS MADERA RAMBO
rambo 6 pieces wood, écrin 6 pièces rambo, bauletto in legno 6 pz. rambo, rambo 6 stück holz
- F **2999** CUCHILLO CHULETERO K6 BOJ SATIN
k6 boj satin steak knife, couteau steak k6 satin boj, coltello bistecca k6 boj satin, steakmesser k6 boj satin
- G **6013** CUCHILLO CHULETERO K6.2 BOJ
k6.2 boj steak knife, couteau steak k6.2 boj, coltello bistecca k6.2 boj satin, steakmesser k6.2 boj
- H **7432** CUCHILLO CHULETERO K6 BOJ SATIN GOLD
boj satin/k6 steak knife gold, couteau steak boj satin/k6 gold, coltello bistecca boj satin/k6 gold, steakmesser boj satin/k6 gold
- I **7433** CUCHILLO CHULETERO K6 BOJ SATIN GUNMETAL
boj satin/k6 steak knife gunmetal, couteau steak boj satin/k6 gunmetal, coltello bistecca boj satin/k6 gunmetal, steakmesser boj satin/k6 gunmetal
- J **7431** CUCHILLO CHULETERO K6 BOJ SATIN COPPER
boj satin/k6 steak knife copper, couteau steak boj satin/k6 copper, coltello bistecca boj satin/k6 copper, steakmesser boj satin/k6 copper

| UE | MOQ | mm |
|--------------------|-----|-----|
| 0/6/60/720/3600 | 60 | 215 |
| 1/12/120/1920/5760 | 120 | 235 |
| 0/6/60/720/3600 | 60 | 232 |
| 0/6/60/720/3600 | 6 | 232 |
| 0/6/60/720/3600 | 60 | 232 |
| 0/6/60/720/3600 | 6 | 232 |
| 0/6/60/720/2880 | 60 | 225 |
| 0/6/60/720/2880 | 6 | 225 |
| 0/6/60/720/2880 | 60 | 221 |
| 1/6/60/720/2880 | 60 | 221 |
| 1/6/60/720/2880 | 60 | 221 |
| 1/6/60/720/2880 | 60 | 221 |
| 1/6/60/720/2880 | 60 | 221 |





3CR13



3CR13



3CR13



| | | UE | MOQ | ▶ mm |
|---|--|-----------------|-----|------|
| A | 7445 CUCHILLO CHULETON ACONCAGUA BLACK aconcagua black steak knife, couteau steak aconcagua black, coltello bistecca aconcagua black, steak messer aconcagua black | 0/6/60/540/2160 | 60 | 177 |
| B | 7446 CUCHILLO CHULETON ACONCAGUA aconcagua steak knife, couteau steak aconcagua, coltello bistecca aconcagua, steak messer aconcagua | 0/6/60/540/2160 | 60 | 165 |
| C | 3100 CUCHILLO CHULETERO CHURRASCO churrasco steak knife, couteau steak churrasco, couteau steak churrasco, coltello bistecca churrasco, steakmesser churrasco | 0/6/60/540/2160 | 60 | 254 |

NEW



| | | UE | MOQ | ▶ mm |
|---|---|-----------------|-----|------|
| A | 12016 CUCHILLO CHULETERO KAMET WENGÉ kamet wengé steak knife, couteau steak kamet wengé, coltello bistecca kamet wengé, steak messer kamet wengé | 0/6/60/540/2160 | 60 | 235 |
| B | 12015 CUCHILLO CHULETERO KAMET ROSEWOOD kamet rosewood steak knife, couteau steak kamet rosewood, coltello bistecca kamet rosewood, steak messer kamet rosewood | 0/6/60/540/2160 | 60 | 235 |
| C | 12031 CUCHILLO CHULETERO LHOSTE PAKKA BLACK lhoste pakka steak knife, couteau steak lhoste pakka, coltello bistecca lhoste pakka, steak messer lhoste pakka | 0/6/60/540/2160 | 60 | 248 |
| D | 12032 CUCHILLO CHULETERO LHOSTE PAKKA RED lhoste pakka steak knife, couteau steak lhoste pakka, coltello bistecca lhoste pakka, steak messer lhoste pakka | 0/6/60/540/2160 | 60 | 248 |
| E | 12033 CUCHILLO CHULETERO LHOSTE PAKKA VERDE lhoste pakka steak knife, couteau steak lhoste pakka, coltello bistecca lhoste pakka, steak messer lhoste pakka | 0/6/60/540/2160 | 60 | 248 |





* Caja 6 chuleteros.

* Compatible con estuches acacia: 5207 /5208

| | UE | MOQ | mm |
|---|-----------------|-----|-----|
| A 7442 CUCHILLO CHULETERO ACR WHITE acr white steak knife, couteau steak acr white, coltello bistecca acr white, steak messer acr white | 0/6/60/720/3600 | 60 | 225 |
| B 7443 CUCHILLO CHULETERO ACR RED acr red steak knife, couteau steak acr red, coltello bistecca acr red, steak messer acr red | 0/6/60/720/3600 | 60 | 225 |
| C 3010 CUCHILLO CHULETERO ACR BLACK steak knife rambo, couteau steak rambo, coltello bistecca rambo, steakmesser rambo | 0/6/60/720/3600 | 60 | 225 |
| 5279 6 PCS MADERA ACR BLACK rambo 6 pieces wood, écriin 6 pièces rambo, bauletto in legno 6 pz. rambo, rambo 6 stück holz | 1/6/78/234 | 6 | 225 |
| D 3011 TENEDOR CHULETERO ACR NEGRO zermatt steak knife, couteau steak zermatt, coltello bistecca zermatt, steakmes- ser zermatt | 0/6/60/720/3600 | 60 | 210 |
| 6335 6 PCS MADERA TENEDOR ACR BLACK kilimanjaro steak knife, couteau steak kilimanjaro, coltello bistecca kilimanjaro, steakmesser kilimanjaro | 1/6/78/234 | 6 | 210 |
| E 7447 CUCHILLO QUESO ZERMATT zermatt cheese knife, couteau à fromage zermatt, coltello da formaggio zermatt, kassmesser zermatt | 0/6/60/540/2160 | 60 | 123 |
| F 6163 CUCHILLO CHULETERO ZERMATT zermatt steak knife, couteau steak zermatt, coltello bistecca zermatt, steakmes- ser zermatt | 0/6/60/780/3120 | 60 | 227 |

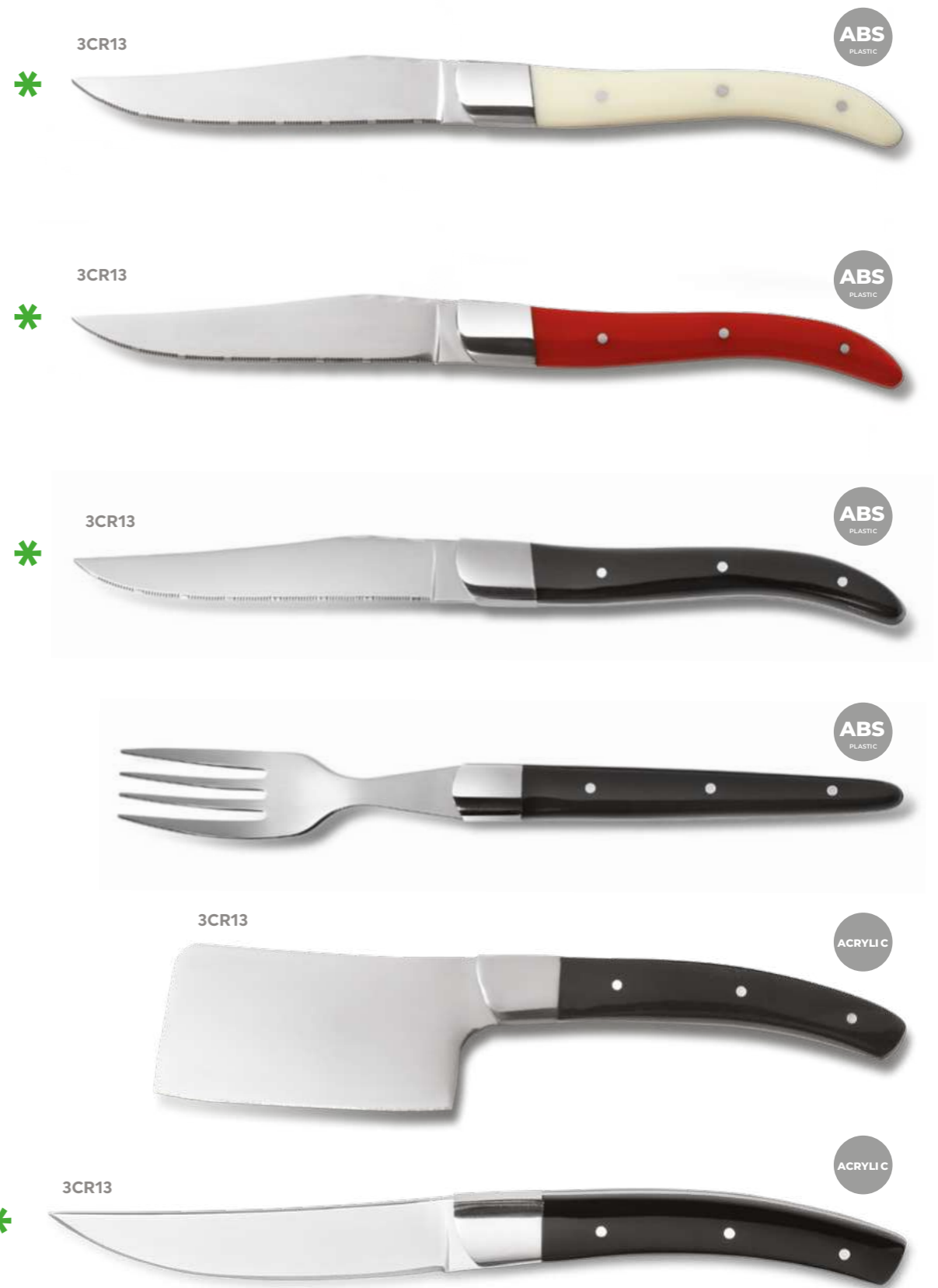

- * 3CR13 ABS PLASTIC A
- * 3CR13 ABS PLASTIC B
- * 3CR13 ABS PLASTIC C
- ABS PLASTIC D
- 3CR13 ACRYLIC E
- * 3CR13 ACRYLIC F



NEW



MIX
6 COLORES
6 COLOURS

REF.: 11993

Sistema de cierre con imán integrado en la madera.

Locking system with magnet integrated in the wood.

Madera de Acacia

Acacia wood



Se recomienda lavar a mano.
Hand washing is recommended



OPCIÓN DE PERSONALIZAR LA CAJA CON LASER. *

OPTION TO CUSTOMISE THE BOX WITH LASERMARK.

1,54€ / PIEZA PIECE

| | UE | MOQ | L x W x Hmm |
|---|-----|-----|----------------|
| A 11993 CAJA ESTUCHE MADERA 6 CHULETEROS MIX COLORES wooden 6 steak knives mix coloured case, 6 couteau steak mix couleurs caisse en bois, scatola di legno 6 coltello bistecca colorate mix, 2 steakmesser holzkistewooden | 1/6 | 6 | 260 x 130 x 40 |
| B 11988 CAJA ESTUCHE MADERA VACÍA 2 CHULETEROS 2 steak knives case, 2 couteau steak caisse en bois, scatola di legno 2 coltello bistecca, 2 steakmesser holzkiste | 1/2 | 2 | 260 x 80 x 35 |
| C 11987 CAJA ESTUCHE MADERA VACÍA 6 CHULETEROS wooden 6 steak knives case, 6 couteau steak caisse en bois, scatola di legno 6 coltello bistecca, 2 steakmesser holzkiste | 1/6 | 6 | 260 x 130 x 40 |



HQ: 7Cr17Mov



Conoce UTSET en la página: 494
More about UTSET in page: 494

Corte / Cuchillos de mesa Cutting / Table knives



Se recomienda lavar a mano.
Hand washing is recommended

Acero inoxidable 7Cr17Mov 7Cr17Mov Stainless steel

El acero de los cuchillos de mesa Utset ha sido tratado térmicamente para alcanzar una alta dureza y resistencia al desgaste y durabilidad, lo que significa que mantendrá su filo y estructura en condiciones de uso exigente.

El acero 7Cr17Mov es un tipo de acero que se ha hecho popular en la fabricación de cuchillos gracias a su resistencia a la corrosión.

The steel in Utset table knives has been heat-treated to achieve high hardness and wear resistance and durability, which means it will maintain its sharpness and structure under demanding conditions of use.

7Cr17Mov steel is a type of steel that has become popular in knife making due to its resistance to corrosion.

Madera estabilizada Stabilised wood

Material fabricado mediante la inyección de resinas termoestables y color en la madera. Con esta inyección de resina se obtiene un sellado de mayor dureza, impermeabilidad y resistencia.

Además, con el color podemos personalizar la madera y crear diferentes patrones y variedad de gamas dándole un toque de sofisticación y originalidad al cuchillo.

Material manufactured by injecting thermosetting resins and color into the wood. With this injection, a seal of greater hardness, impermeability and resistance is obtained.

In addition, with colour we can personalise the wood and create different patterns and a variety of ranges, giving a touch of sophistication and originality to the knife.



Conoce
UTSET.



ALTA DUREZA
HIGH HARDNESS
54-1 HRC  5Cr15Mov



Se recomienda lavar a mano.
Hand washing is recommended

| | UE | MOQ | ✂ mm |
|---|-----------------|-----|------|
| A 12005 CUCHILLO ABREOSTRAS CON FUNDA oyster knife with sleeve, couteau à huîtres avec étui, apriostriche con fodero, austernmesser mit scheid | 1/6/60 | 6 | 148 |
| B 11018 CUCHILLO DE MESA UTSET OLIVO olive knife, couteau a olivier, coltello oliva, olivenmesser | 0/6/60/540/2160 | 6 | 225 |
| C 11019 CUCHILLO DE MESA UTSET ÉBANO ebony knife, couteau a ebène, coltello ebano, ebenholz-messer | 0/6/60/540/2160 | 6 | 225 |
| D 11067 CUCHILLO DE MESA MADERA ESTABILIZADA AZUL blue stabilized wood knife, couteau en bois stabilisé bleu, coltello in legno stabilizzato blue, blaues stabilisiertes holzmesser | 0/6/60/540/2160 | 6 | 225 |
| E 11068 CUCHILLO DE MESA MADERA ESTABILIZADA VERDE green stabilized wood knife, couteau en bois stabilisé vert, coltello in legno stabilizzato verde, grünes stabilisiertes holzmesser | 0/6/60/540/2160 | 6 | 225 |
| F 11069 CUCHILLO DE MESA MADERA ESTABILIZADA NATURAL natural stabilized wood knife, couteau en bois stabilisé chaud, coltello in legno stabilizzato calce, kalk stabilisiertes holzmesser | 0/6/60/540/2160 | 6 | 225 |
| G 11070 CUCHILLO DE MESA MADERA ESTABILIZADA NARANJA orange stabilized wood knife, couteau en bois d'orange stabilisé, coltello in legno stabilizzato d'arancio, orange stabilisiertes holzmesser | 0/6/60/540/2160 | 6 | 225 |
| H 11071 CUCHILLO DE MESA MADERA ESTABILIZADA NEGRA black stabilized wood knife, couteau en bois stabilisé noir, coltello in legno stabilizzato nero, schwarzes stabilisiertes holzmesser | 0/6/60/540/2160 | 6 | 225 |
| I 11072 CUCHILLO DE MESA MADERA ESTABILIZADA ROJA red stabilized wood knife, couteau en bois stabilisé rouge, coltello in legno stabilizzato rosso, rot stabilisiertes holzmesser | 0/6/60/540/2160 | 6 | 225 |

Conoce UTSET en la página: 494
More about UTSET in page: 494

Corte / Cuchillos de mesa
Cutting / Table knives

NEW 

EXTRA DURO
EXTRA HARD
57-59 HRC  7Cr17Mov



MIX
6 COLORES
6 COLOURS

REF.: 11993
PAG.: 203



| | | UE | MOQ | ▶ mm |
|---|--|--------------------|-----|------|
| A | 2072 CUCHILLO CHULETERO PERFECT perfect steak knife, couteau steak perfect, coltello bistecca perfect, perfekt steakmesser | 0/12/120/1920/5760 | 120 | 224 |
| B | 5903 TENEDOR CHULETERO PERFECT perfect steak fork, fourchette steak perfect, forchetta bistecca perfect, perfekt steakgabel | 0/12/120/1920/7200 | 120 | 195 |
| C | 2732 CUCHILLO CHULETERO PERFECT PREMIUM perfect premium steak knife, couteau steak perfect premium, coltello bistecca perfect premium, perfekt premium steakmesser | 0/12/120/1920/5760 | 120 | 224 |
| D | 5447 CUCHILLO CHULETERO PERFECT ECO 2 perfect steak knife lacasa, 2 couteau steak perfect lacasa, 2 coltello bistecca perfect lacasa, 2 perfekt steakmesser lacasa | 2/0/48/1008/2016 | 48 | 215 |
| E | M1538 2 CUCHILLO CHULETERO PERFECT ECO nordic steak knife, couteau steak nordic, coltello bistecca nordic, nordic steakmesser | 0/12/120/1920/5760 | 60 | 230 |
| F | 5631 CUCHILLO CHULETERO NORDIC nordic steak knife, couteau steak nordic, coltello bistecca nordic, nordic steakmesser | 0/12/120/1920/5760 | 120 | 224 |
| G | 4713 CUCHILLO CHULETERO NORDIC ECO nordic steak knife eco, couteau steak nordic eco, coltello bistecca nordic eco, nordic steakmesser eco | 0/12/120/1920/5760 | 120 | 230 |
| H | 1339 CUCHILLO CHULETERO MADRID steak knife, couteau steak madrid, coltello bistecca madrid, steakmesser madrid | 0/12/120/1920/5760 | 120 | 230 |



| | | UE | MOQ | ▶ mm | ✕ mm |
|---|--|--------------------|-----|------|------|
| A | 3263 CUCHILLO PIZZA pizza knife, couteau pizza, coltello pizza, pizza tafelmesser | 0/12/120/1920/5760 | 120 | 205 | |
| B | 3264 TENEDOR PIZZA pizza fork, fourchette pizza, forchetta pizza, pizza gabel | 0/12/120/1920/5760 | 120 | 202 | 4 |
| C | 3265 BLISTER 3 CUCHILLO PIZZA blister 3 pizza knife, blister 3 couteau pizza, blister 3 coltello pizza, blister pizza-messer | 1/0/24/4561/2280 | 24 | 205 | |
| D | 3266 BLISTER CUCHILLO + TENEDOR PIZZA blister pizza knife + fork, blister couteau + fourchette pizza, blister coltello + forchetta pizza, blister pizza messer + gabel | 1/0/48/576/2304 | 48 | 205 | 4 |





| | | UE | MOQ | ✂ mm |
|---|---|------------------|-----|------|
| A | 7535 CUCHILLO CHULETERO ROJO PUNTILLA steak knife red couteau steak red coltello bistecca rosso steakmesser rot | 1/0/48/1152/2304 | 24 | 230 |
| B | 8301 BLISTER CHULETERO ROJO PUNTILLA steak knife red 2 blister blister 2 couteau steak red blister 2 coltello bistecca rosso blister 2 steakmesser red | 1/0/24/0/0 | 24 | 230 |
| C | 11585 CUCHILLO CHULETERO NEGRO PUNTILLA steak knife, couteau steak, coltello bistecca, steakmesser | 1/0/48/1152/2304 | 24 | 230 |
| D | 10990 BLISTER 6 CHULETERO FINO SIERRA blister 6 slim serrated steak knife blister 6 couteaux steak avec lame dentelée blister 6 coltelli bistecca lama dentata blister de 6 couteaux à steak avec lame dentelée | 1/12/24/0/0 | 48 | 215 |
| E | 10991 BLISTER 6 CHULETERO FINO LISO blister 6 fine smooth steak knife blister 6 couteaux steak avec lame lisse blister 6 icoltelli bistecca lama liscia blister 6 fine smooth steak knife | 1/12/48/0/0 | 48 | 215 |
| F | 10992 BLISTER 6 CUCHILLO MESA ECO blister 6 eco table knife blister de 6 couteaux table eco blister 6 coltelli tavola eco blister 6 eco table knife | 1/12/48/0/0 | 48 | 215 |
| G | 10993 BLISTER 2 CHULETERO FORJADO blister 2 forged steak knife blister 2 couteaux steak forgés blister 2 coltelli bistecca forgiati blister 2 forged steak knife | 1/12/48/0/0 | 48 | 225 |



| | | UE | MOQ | ✂ mm |
|---|--|---------------------|-----|------|
| A | 3002 CHULETON NEGRO big black steak knife, gros couteau steak noir, grande coltello bistecca nero, gros steakmesser schwarz | 0/12/120/2520/5040 | 120 | 232 |
| B | 3004 CHULETERO FINO NEGRO black thin steak knife, couteau steak fin noir, coltello bistecca sottile nero, steakmesser schwarz dünn | 0/12/120/2880/5760 | 120 | 212 |
| C | 3003 TENEDOR CHULETERO NEGRO black steak fork, fourchette steak noire, forchetta bistecca nera, steakgabel schwarz | 0/12/120/2520/5040 | 120 | 191 |
| D | 0072 CUCHILLO MANTECA MARFIL ivory knife couteau ivoire coltello avorio elfenbeinmesser | 0/12/288/6336/19008 | 288 | 200 |
| E | 3006 CHULETERO ECO eco steak knife, couteau steak eco, coltello bistecca eco, steakmesser eco | 0/6/144/2304/6912 | 144 | 220 |



Acabados y PVD

Finishes and PVD

Sorprende con una nueva forma de vestir la mesa con un toque distinto y elegante gracias a nuestros cubiertos con recubrimiento PVD (Physical Vapor Deposition).

Este innovador proceso no solo otorga un acabado espectacular a cada pieza, sino que también asegura una mayor resistencia y durabilidad, para que tus cubiertos luzcan como nuevos por más tiempo.

El recubrimiento PVD no es solo estética; es una tecnología avanzada que aporta una capa protectora ultra resistente a los arañazos, corrosión y el desgaste del día a día.

Los cubiertos PVD combinan diseño moderno con un rendimiento inigualable. Haz de cada comida una experiencia extraordinaria con la calidad y sofisticación que solo el recubrimiento PVD puede ofrecer.

Surprise with a new way of dressing the table with a different and elegant touch thanks to our cutlery with PVD (Physical Vapor Deposition) coating.

This innovative process not only gives each piece a spectacular finish, but also ensures greater strength and durability, so your cutlery will look as good as new for longer.

PVD coating is not just about aesthetics; it is an advanced technology that provides an ultra-resistant protective layer against scratches, corrosion and everyday wear and tear.

PVD cutlery combines modern design with unrivalled performance. Make every meal an extraordinary experience with the quality and sophistication that only PVD coating can offer.



Acabados Finishes

Escoge el acabado que prefieras para cualquier colección del catálogo.
Choose the finish you prefer for any collection in the catalogue.



VINTAGE

Aspecto antiguo y desgastado que proporciona elegancia a la pieza. Efecto envejecido.

Ancient and worn aspect that gives elegance to the piece. Aged effect.



SATIN

Este tratamiento regala al cubierto un efecto satinado agradable al tacto.

This treatment gives the cover a satin effect pleasant to the touch.



MIRROR

El acabado más extremado, efecto espejo, sumará elegancia y sofisticación a la mesa.

The most extreme finish, mirror effect, will add elegance and sophistication to the table.

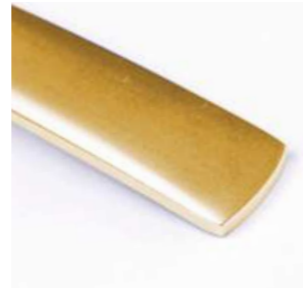

ICE POLVO DE LUNA

Efecto granulado "shot blasting". Acabado mate, suave y liso, que resalta la delicadeza de cada pieza.

"Shot blasting" effect. A matt and smooth finish that stand out the delicacy of every piece.



SILVER PLATE

Dale un toque de distinción a tus cubiertos añadiendo un acabado en plata.

Add a touch of distinction to your cutlery by adding a silver plated.



LASER MARK

Escoge la cubertería y customiza con tu logo cada una de las piezas.

Choose the cutlery and customize each piece with your logo.



TAMPO

Personaliza con los motivos que prefieras las piezas de tu cubertería.

Personalize with the motives that you prefer the pieces of your cutlery.

Plazo entrega 30 días. Delivery time 30 days.



Certificado SGS de calidad.
SGS Quality Certificate.



Garantizado para el contacto con alimentos.
Guaranteed for contact with food.



Garantizado el lavado en lavavajillas.
Guaranteed dishwashing.

COCINA

KITCHEN



Download
Cutting
Catalogue

216



218 CORTE / STEAK KNIVES

- 218 TABLAS DE CORTE
- 222 PUNTILLAS
- 224 CUCHILLOS COCINA
 - 226 CARBON
 - 230 IBÉRICA
 - 232 MARBLE
 - 236 ZEN
 - 240 130
 - 242 MESTRE MAURICI
- 246 ACCESORIOS
- 254 RALLADORES Y ACCESORIOS DE CORTE
- 260 ESPÁTULAS

262 UTENSILIOS / UTENSILS

- 262 EMPLATADO
- 264 JUEGOS COCINA
 - 264 MONOBLOCK
 - 266 NYLON
- 274 PASTELERÍA

276 COCCIÓN / COOKING

- 280 SARTENES PROFESIONALES ALUMINIO
- 283 SARTENES PROFESIONALES INOX
- 284 GAMA CROSCAT
- 288 PAELLERAS
- 292 AMT
- 302 RISOLÍ

320 GASTRONORM

- 322 CUBERTAS GN AISI 304 - 18/10
- 326 CUBETAS GN INOX
- 331 CARROS

217



Espesores de 2cm y 3cm.
2cm and 3cm Thicknesses.



Tacos antideslizantes de silicona para un mejor agarre en la superficie.
Silicone anti-slip pads for better grip on the surface.



Mayor rigidez. No se deforma con las altas temperaturas. Máx. 70°C
Higher rigidity, no deformation at high temperatures. Max. 70°C



Apto para contacto con alimentos.
Suitable for food contact.



Apto para lavavajillas.
Dishwasher safe.



Impermeable. No absorbe los líquidos.
SUPERFICIE AUTOCICATRIZANTE
Más higiénica. Evita que se acumule suciedad y bacterias en los cortes.

Waterproof, does not absorb liquids.

AUTOHEAL SURFACE
More hygienic, prevents dirt and bacteria from accumulating in the cuts.



POLIETILENO 500 DE ALTA DENSIDAD DE ALTO PESO MOLECULAR(HD-HMW)

HIGH MOLECULAR WEIGHT HIGH DENSITY POLYETHYLENE 500 (HD-HMW)

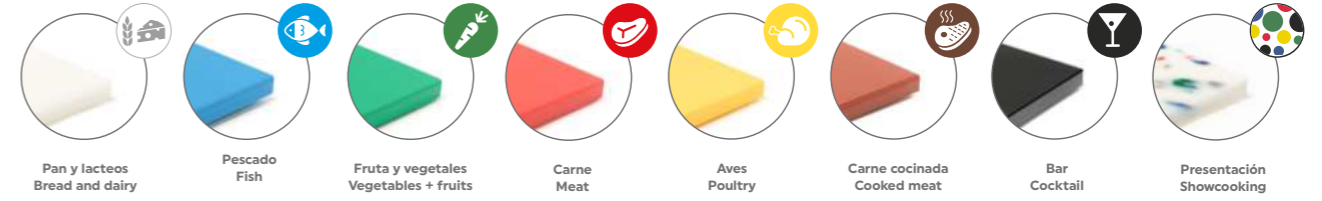
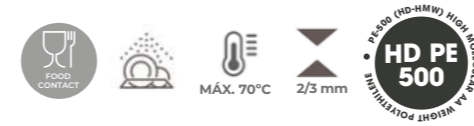

GN 1/1



GN 1/2



20x30cm



30x40cm



40x50cm

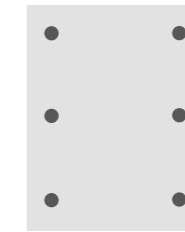

40x60cm

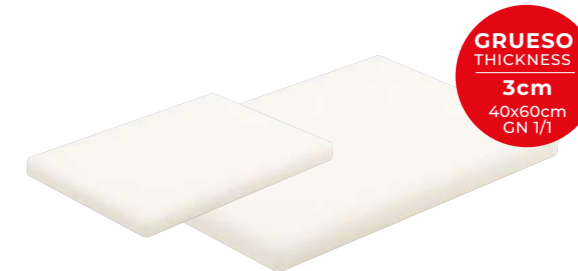
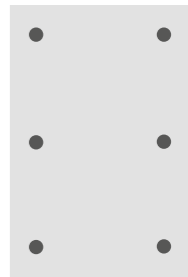

GRUESO THICKNESS
3cm
40x60cm
GN 1/1

Tabla corte pan y lacteos blanca
White cutting board
Planche à découper blanche
Tagliere bianco
Wibes schneidebrett



| REF. | W mm | L mm | ESPEJOR cm | TACOS | € | UE / MOQ |
|------------------|--------|--------|------------|-------|---|-------------------|
| NEW 11756 | GN 1/1 | GN 1/1 | 3 | 6 | | 1-0-4 / 1 |
| 8523 | GN 1/2 | GN 1/2 | 2 | 6 | | 1-0-10-60-180 / 1 |
| 8525 | 300 | 200 | 2 | 4 | | 1-0-10-60-180 / 1 |
| 8526 | 400 | 300 | 2 | 6 | | 1-0-6-36-108 / 1 |
| 8527 | 500 | 300 | 2 | 6 | | 1-0-6-36-108 / 1 |
| NEW 11758 | 600 | 400 | 3 | 6 | | 1-0-2 / 1 |

NEW

Tabla corte bar
Black cutting board
Planche à découper noir
Tagliere nero
Schwarzes schneinebrett



| REF. | WxL cm | ESPEJOR cm | TACOS | € | UE / MOQ |
|-------|--------|------------|-------|---|-------------------|
| 11760 | 30x20 | 2 | 4 | | 1-0-5-30-90 / 1 |
| 11759 | 40x30 | 2 | 6 | | 1-0-10-60-180 / 1 |

NEW

Tabla corte presentación
Cutting board presentation
Présentation de la planche à découper
Presentazione del tagliere
Präsentation des Schneebrett



| REF. | W.L cm | ESPEJOR cm | TACOS | € | UE / MOQ |
|-------|--------|------------|-------|---|---------------|
| 11998 | 30x20 | 2 | 4 | | 1-0-8-0-0 / 1 |

Tabla corte pescado azul
Blue cutting board
Planche à découper bleu
Tagliere blue
Blau schneidebrett



| REF. | W mm | L mm | ESPEJOR cm | TACOS | € | UE / MOQ |
|------|--------|--------|------------|-------|---|-------------------|
| 8529 | GN 1/1 | GN 1/1 | 2 | 6 | | 1-0-5-30-90 / 1 |
| 8532 | 300 | 200 | 2 | 4 | | 1-0-10-60-180 / 1 |
| 8533 | 400 | 300 | 2 | 6 | | 1-0-6-36-108 / 1 |
| 8534 | 500 | 300 | 2 | 6 | | 1-0-6-36-108 / 1 |
| 8535 | 600 | 400 | 2 | 6 | | 1-0-4-24-72 / 1 |

Tabla corte fruta y vegetales verde
Green cutting board
Planche à découper vert
Tagliere verde
Grün schneidebrett

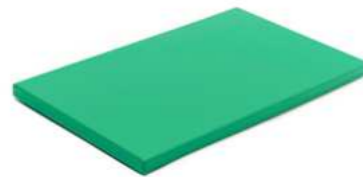

| REF. | W mm | L mm | ESPEJOR cm | TACOS | € | UE / MOQ |
|------|--------|--------|------------|-------|---|-------------------|
| 8536 | GN 1/1 | GN 1/1 | 2 | 6 | | 1-0-5-30-90 / 1 |
| 8539 | 300 | 200 | 2 | 4 | | 1-0-10-60-180 / 1 |
| 8540 | 400 | 300 | 2 | 6 | | 1-0-6-36-108 / 1 |
| 8541 | 500 | 300 | 2 | 6 | | 1-0-6-36-108 / 1 |
| 8542 | 600 | 400 | 2 | 6 | | 1-0-4-24-72 / 1 |

Tabla corte carne cruda roja
Red cutting board
Planche à découper rouge
Tagliere rosso
Rot schneidebrett



| REF. | W mm | L mm | ESPEJOR cm | TACOS | € | UE / MOQ |
|------|--------|--------|------------|-------|---|-------------------|
| 8543 | GN 1/1 | GN 1/1 | 2 | 6 | | 1-0-5-30-90 / 1 |
| 8546 | 300 | 200 | 2 | 4 | | 1-0-10-60-180 / 1 |
| 8547 | 400 | 300 | 2 | 6 | | 1-0-6-36-108 / 1 |
| 8548 | 500 | 300 | 2 | 6 | | 1-0-6-36-108 / 1 |
| 8549 | 600 | 400 | 2 | 6 | | 1-0-4-24-72 / 1 |



Tabla corte carne cruda aves amarilla
Yellow cutting board
Planche à découper jaune
Tagliere giallo
Gelb schneidebrett



| REF. | W mm | L mm | ESPEJOR cm | TACOS | € | UE / MOQ |
|------|--------|--------|------------|-------|---|-------------------|
| 8550 | GN 1/1 | GN 1/1 | 2 | 6 | | 1-0-5-30-90 / 1 |
| 8553 | 300 | 200 | 2 | 4 | | 1-0-10-60-180 / 1 |
| 8554 | 400 | 300 | 2 | 6 | | 1-0-6-36-108 / 1 |
| 8555 | 500 | 300 | 2 | 6 | | 1-0-6-36-108 / 1 |
| 8556 | 600 | 400 | 2 | 6 | | 1-0-4-24-72 / 1 |

Tabla corte carnes cocidas marrón
Brown cutting board
Planche à découper marron
Tagliere marrone
Braun schneidebrett



| REF. | W mm | L mm | ESPEJOR cm | TACOS | € | UE / MOQ |
|------|--------|--------|------------|-------|---|-------------------|
| 8557 | GN 1/1 | GN 1/1 | 2 | 6 | | 1-0-5-30-90 / 1 |
| 8560 | 300 | 200 | 2 | 4 | | 1-0-10-60-180 / 1 |
| 8561 | 400 | 300 | 2 | 6 | | 1-0-6-36-108 / 1 |
| 8562 | 500 | 300 | 2 | 6 | | 1-0-6-36-108 / 1 |
| 8563 | 600 | 400 | 2 | 6 | | 1-0-4-24-72 / 1 |

NEW

Soporte inox para tablas
Cutting board support
Support planche à découper
Supporto tagliere
Schneidebretthalterung

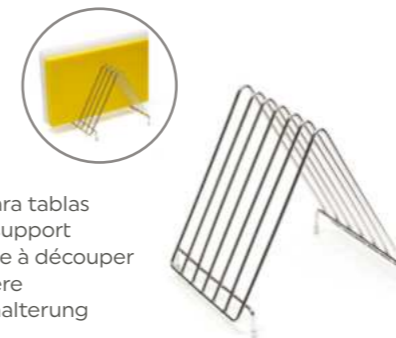

| REF. | W mm | L mm | H mm | € | UE / MOQ |
|-------|------|------|------|---|------------|
| 11640 | 265 | 310 | 280 | | 1-0-20 / 1 |

NEW

Rascador para tabla
Cutting board scraper
Brosse pour planche à découper
Spazzola per tagliere
Reinigungsbürste für Schneebrett



| REF. | W mm | L mm | H mm | € | UE / MOQ |
|-------|------|------|------|---|------------|
| 11761 | 60 | 170 | 90 | | 1-0-36 / 1 |

NEW

Pack 6 tacos silicona
6 Pack rubber stoppers
Pack 6 tacos silicone
Confezione di 6 tacos in silicone
Pack 6 taco-ständer silikon



| REF. | TACOS | € | UE / MOQ |
|-------|-------|---|--------------|
| 11941 | 6 | | 1-0-1000 / 1 |

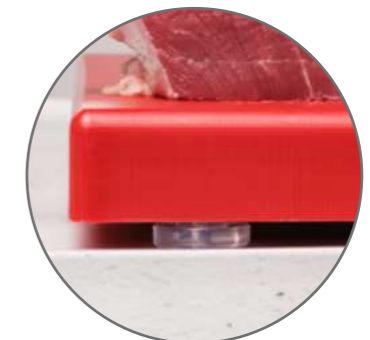

ACERO:
3Cr13

PP
POLYPROPYLENE
MANGO



Cuchillo multiusos.
Micro serrated knife.



Cuchillo pelador.
Peeling knife.



Cuchillo chuletero.
Steak knife.



Cuchillo fruta micro.
Micro serrated fruit knife.

El 3Cr13MoV es un acero inoxidable sólido que ofrece una buena resistencia a la corrosión, dureza y de fácil afilado. Es ideal para aquellos que quieren un cuchillo de bajo mantenimiento y uso general. Se desempeña de manera óptima en las tareas típicas de corte.

3Cr13MoV is a solid stainless steel that offers good corrosion resistance, hardness and easy sharpening. It is ideal for those who want a low-maintenance, general-purpose knife. It performs optimally in typical cutting tasks.

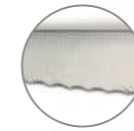

Cuchillo chuletero
Steak knife
Couteau steak
Coltello bistecca
Steakmesser

| REF. | HOJA (mm) | L (mm) | € | UE / MOQ |
|------|--------------|--------|---|--------------------------|
| 7535 | 120 | 230 | | 1-24-240-7200-21600 / 24 |
| 8301 | BLISTER 2 U. | | | 1-0-24-360-1440 / 24 |

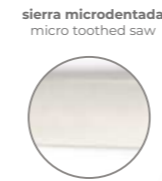

sierra microdentada
micro toothed saw



Cuchillo fruta micro
Micro serrated fruit knife
Couteau à fruits micro
Coltello fruta micro
Universalmesser Obst micr

| REF. | HOJA (mm) | L (mm) | € | UE / MOQ |
|------|--------------|--------|---|--------------------------|
| 7538 | 88 | 199 | | 1-24-240-7200-21600 / 24 |
| 8304 | BLISTER 2 U. | | | 1-0-24-360-1440 / 24 |



Cuchillo chuletero
Steak knife
Couteau steak
Coltello bistecca
Steakmesser

| REF. | HOJA (mm) | L (mm) | € | UE / MOQ |
|-------|-----------|--------|---|----------------------|
| 11585 | 120 | 230 | | 1-0-24-360-1440 / 24 |



Cuchillo pelador
Peeling knife
Couteau à éplucher
Coltello spellucchino
Schälmesser

| REF. | HOJA (mm) | L (mm) | € | UE / MOQ |
|-------|-----------|--------|---|----------------------|
| 11586 | 80 | 195 | | 1-0-24-360-1440 / 24 |

sierra microdentada
micro toothed saw



Cuchillo multiusos micro
Micro serrated utility knife
Couteau multi-usage micro
Coltello multiuso micro
Universalmesser micro

| REF. | HOJA (mm) | L (mm) | € | UE / MOQ |
|------|--------------|--------|---|--------------------------|
| 7537 | 100 | 09 | | 1-24-240-7200-21600 / 24 |
| 8303 | BLISTER 2 U. | | | 1-0-24-360-1440 / 24 |

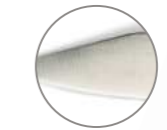

Cuchillo pelador
Peeling knife
Couteau à éplucher
Coltello spellucchino
Schälmesser

| REF. | HOJA (mm) | L (mm) | € | UE / MOQ |
|------|--------------|--------|---|--------------------------|
| 7536 | 80 | 195 | | 1-24-240-7200-21600 / 24 |
| 8302 | BLISTER 2 U. | | | 1-0-24-360-1440 / 24 |



Cuchillo multiusos micro
Micro serrated utility knife
Couteau multi-usage micro
Coltello multiuso micro
Universalmesser micro

| REF. | HOJA (mm) | L (mm) | € | UE / MOQ |
|-------|-----------|--------|---|----------------------|
| 11587 | 100 | 09 | | 1-0-24-360-1440 / 24 |

PACKAGING
BOX





PUNTILLA / MONDADOR / UTILITY

Versátil, tanto para fruta y verdura, como para piezas pequeñas de carne. Versatile, both for fruit and vegetables, as well as for small pieces of meat.



PELADOR / VERDURAS / PEELING

Para trabajos pequeños y delicados. For small and delicate jobs.



DESHUESADOR / WRECKER

Su forma permite acceder a la carne y retirar huesos y tendones sin perder la forma. Its shape allows access to the flesh and the removal of bones and tendons without losing its shape.



JAMONERO / SLICER

Indicado para cortar jamón y carnes curadas. Suitable for cutting ham and cured meats.



SALMÓN / SALMON KNIFE

Hoja fina y alargada, con alvéolos para evitar que la carne se adhiera a la hoja. Thin, elongated blade, with sockets to prevent meat from sticking to the blade.



PANERO / BREAD KNIFE

Hoja dura y dentada que permite cortar alimentos con el exterior rígido con facilidad. Hard, serrated blade for easy cutting of food with a rigid exterior.



HACHA / CLEAVER

Hoja grande y gruesa que se utiliza para cortar y desosar carne cruda o cocinada. A large, thick blade used for cutting and boning raw or cooked meat.



FILETADOR / SLICER

Hoja larga y flexible que permite preparar carne y pescado con precisión. Long, flexible blade for precise meat and fish preparation.



SANTOKU / SANTOKU

Versión japonesa del cuchillo chef, ideal para preparar carne, pesca y verduras. Japanese version of the chef's knife, ideal for preparing meat, fish and vegetables.



CHEF / CHEF

El más popular de los cuchillos, con hoja grande y resistente sirve para todo tipo de cortes. The most popular of the knives, with a large, sturdy blade for all types of cutting.

La gama de productos de corte Comas, ha sido creada y mejorada para ofrecer a los cocineros y jefes de cocina, una amplia variedad de utensilios y cuchillos para corte que garantizan la calidad y durabilidad necesaria para el día a día de las cocinas profesionales.

The Comas range of cutting products has been created and improved to offer chefs and wide variety of cutting utensils and knives that guarantee the quality and durability necessary for everyday use in professional kitchens.



| COLECCIÓN COLLECTION | GRANITE | IBERICA | MARBLE | ZEN | 130 | MAURICI |
|-------------------------|---------|---------|--------|-----|-----|---------|
|-------------------------|---------|---------|--------|-----|-----|---------|



| | | | | | | |
|---|---------------------|---------------------|---------------------|----------------|-------------------------------|--|
| MATERIAL | X50 Cr Mo V15 | X50 Cr Mo V15 | DIN 1.4116 | AUS 8 SANMAI | AUS 10 SANMAI | CARBON STEEL 52100 |
| DUREZA DE LA HOJA BLADE HARDNESS | HRC55 ± 57 | HRC55 ± 57 | HRC55 ± 2 | HRC58 ± 2 | HRC60 ± 1 | HRC62 ± 2 |
| MANGO HANDLE | POLIPROPILENO | POLIPROPILENO | ABS | POM | MADERA DE ÉBANO EBONY WOOD | ABEDUL ESTABILIZADO ABEDUL ESTABILIZADO |
| ORIGEN MATERIA PRIMA RAW MATERIAL ORIGIN | ALEMANIA GERMANY | ALEMANIA GERMANY | ALEMANIA GERMANY | CHINA CHINA | JAPÓN JAPAN | JAPÓN JAPAN |
| LAVAVAJILLAS DISHWASHER | ✓ | ✓ | ✗ | ✗ | ✗ | ✗ |

El afilado de las hojas hecho manualmente. Garantiza un afilado perfecto y duradero.

Blades sharpening is carried out manually. Guarantees a perfect and durable sharpening.

La forma convexa de la hoja en ambas caras otorga a la hoja un grosor más continuado hasta el filo, garantizando una mayor firmeza en el corte. El pulido asegura un acabado liso e impecable.

The convex line of the blade on both sides grants the blade a more skiving continuing thickness up to the edge, ensuring a steadfast cutting. The polishing ensures a flawless flattening and finishing.

Alta calidad en el corte
 Resistencia a la corrosión

Strong cutting ability
 Resistant to corrosion.



Sello de calidad del fabricante y su compromiso de durabilidad y fiabilidad del producto.

Manufacturer's seal of quality and commitment to product durability and reliability.

TechFlex: Polímeros de PP con EVA para más sensibilidad, adherencia, confort y disminución de fatiga.

TechFlex: Polymers of PP with EVA for a more sensitivity, adhesion, comfort and decreased fatigue

Mangos ergonómicos y antideslizantes para una mayor sujeción.

Ergonomic, non-slip handles for a better grip.



El X50CrMoV15 es un excelente acero inoxidable de gama media que ofrece un rendimiento completo en cuchillos de cocina y cuchillos multiusos con una gran resistencia a la corrosión y una buena retención del filo. Es fácil de afilar, por lo que es ideal para aquellos que prefieren cuchillos de bajo mantenimiento que se pueden mantener afilados sin necesidad de un afilado profesional.

X50CrMoV15 is an excellent mid-range stainless steel that offers all-round performance in kitchen knives and utility knives, with high corrosion resistance and good edge retention. It is easy to sharpen, making it ideal for those who prefer low maintenance knives that can be kept sharp without the need for professional sharpening.



- 10074
 - 10093
 - 10104
 - 10114
 - 10128
- Cuchillo chef 180**
 Chef knife 180
 Couteau de cuisine 180
 Coltello chef 180
 Kochmesser 180

UE / MOQ:
 1-12-144-576-1728 / 12



- 10075
 - 10094
 - 10105
 - 10115
 - 10129
- Cuchillo chef 200**
 Chef knife 200
 Couteau de cuisine 200
 Coltello chef 200
 Kochmesser 200

UE / MOQ:
 1-12-72-288-864 / 12



- 10076
 - 10095
 - 10106
 - 10116
 - 10130
- Cuchillo chef 250**
 Chef knife 250
 Couteau de cuisine 250
 Coltello chef 250
 Kochmesser 250

UE / MOQ:
 1-12-72-288-864 / 12



- 10077
 - 10096
 - 10107
 - 10117
 - 10131
- Cuchillo chef 300**
 Chef knife 300
 Couteau de cuisine 300
 Coltello chef 300
 Kochmesser 300

UE / MOQ:
 1-6-48-192-576 / 6



- 10079
- 10098
- 10109
- 10119

Cuchillo carnicero 160
Butcher knife 160
Couteau boucher 160
Coltello scannare 160
Fleischermesser 180

UE / MOQ:
1-12-144-576-1728 / 12



- 10080
- 10099
- 10110
- 10120

Cuchillo carnicero 180
Butcher knife 180
Couteau boucher 180
Coltello scannare 180
Fleischermesser 180

UE / MOQ:
1-12-144-576-1728 / 12



- 10081
- 10100
- 10111
- 10121

Cuchillo carnicero 200
Butcher knife 200
Couteau boucher 200
Coltello scannare 200
Fleischermesser 200

UE / MOQ:
1-12-72-288-864 / 12



- 10082
- 10101
- 10112
- 10122

Cuchillo carnicero 240
Butcher knife 240
Couteau boucher 240
Coltello scannare 240
Fleischermesser 240

UE / MOQ:
1-12-72-288-864 / 12



- 10083
- 10102
- 10113
- 10123

Cuchillo carnicero 300
Butcher knife 300
Couteau boucher 300
Coltello scannare 300
Fleischermesser 300

UE / MOQ:
1-6-48-192-576 / 6



- 10092

Cuchillo chuletero 130
Steak knife 130
Couteau à steak 130
Coltello per bistecca 130
Steakmesser 130

UE / MOQ:
1-12-60-240-720 / 12



- 10078
- 10097
- 10108
- 10118

Cuchillo deshuesador 140
Wrecker knife 140
Couteau de desossage 140
Coltello disossato 140
Ausbeinmesser 140

UE / MOQ:
1-12-144-576-1728 / 12



- 10084
- 10127

Cuchillo pan y pastelero 250
Bread and pastry knife 250
Couteau à pain et pâtisserie 250
Coltello pane 250
Brotmesser 250

UE / MOQ:
1-12-72-288-864 / 12



- 10085
- 10124

Cuchillo para fiambres 300
Slicing knife 300
Couteau à charcuterie 300
Coltello affettati 300
Tranchiermesser 300

UE / MOQ:
1-6-48-192-576 / 6



- 10086
- 10103
- 10125

Cuchillo salmón 300
Salmon knife 300
Couteau saumon 300
Coltello salmone 300
Lachsmesser 300

UE / MOQ:
1-6-48-192-576 / 6



- 10087
- 10126

Cuchillo jamonero 280
Ham knife 280
Couteau à jambon 280
Coltello prosciutto 280
Schinkenmesser 280

UE / MOQ:
1-6-48-192-576 / 6





Ideal para cortar o filetear.
Ideal for slicing or filleting.

Mango ergonómico
y antideslizante.
Ergonomic, non-slip
handle.

Hoja de bajo espesor que
lo hace ligero y facilita el
manejo.
Thin blade makes it light
and easy to handle.

Los cuchillos de la línea IBÉRICA al igual que GRANITE, están fabricados en acero X50 CrMo V15 y pueden ser utilizados para cortar o filetear gracias a su fino espesor. Esta gama presenta un mango moderno, ergonómico y antideslizante que garantiza un mayor confort y seguridad en su uso.

The knives of the IBÉRICA line, like GRANITE, are made of X50 CrMo V15 steel and can be used for cutting or filleting thanks to their thin thickness. This range has a modern, ergonomic and non-slip handle that guarantees greater comfort and safety in use.



Macheta 180
Cleaver 180
Couperet 180
Mannaietta 180
Hackmesser 180

| REF. | HOJA (mm) | L(mm) | € | UE / MOQ |
|---------|-----------|-------|---|---------------------|
| ● 10088 | 180/7" | 300 | | 1-12-12-48-144 / 12 |



Hachuela 250
Cleaver 250
Couperet 250
Mannaietta 250
Hackmesser 250

| REF. | HOJA (mm) | L(mm) | € | UE / MOQ |
|---------|-----------|-------|---|---------------------|
| ● 10089 | 250/10" | 345 | | 1-12-12-48-144 / 12 |



Macheta filetera 220
Fillets cleaver 220
Couperet filet 220
Mannaietta per affettare 220
Filetirmesser 220

| REF. | HOJA (mm) | L(mm) | € | UE / MOQ |
|---------|-----------|-------|---|-----------------|
| ● 10090 | 220/8.6" | 315 | | 1-6-6-24-72 / 6 |



Macheta filetera 280
Fillets cleaver 280
Couperet filet 280
Mannaietta per affettare 280
Filetirmesser 280

| REF. | HOJA (mm) | L(mm) | € | UE / MOQ |
|---------|-----------|-------|---|---------------|
| ● 10091 | 280/11" | 362 | | 1-6-6-24-72/6 |

ACERO:
GERMAN
STEEL
DIN 1.4116

DUREZA:
HRC55 ± 2

ABS
PLASTIC
MANGO

La colección Marble está creada por 12 cuchillos exclusivos. Están realizados en acero alemán que garantiza la calidad por su alta resistencia. Este conjunto, caracterizado por su diseño funcional, destaca por su elegante color blanco. El aliado perfecto para cualquier profesional de la cocina

The Marble collection consists of 12 exclusive knives. They are made of German steel, which guarantees quality and high resistance. This set, characterised by its functional design, stands out for its elegant white colour. The perfect ally for any kitchen professional.



El acero alemán DIN 1.4116 es reconocido por su calidad excepcional y versatilidad, que lo convierte en uno de los materiales preferidos en la fabricación de cuchillos.

Su composición equilibrada ofrece una resistencia superior al desgaste y la oxidación, esto significa que mantienen el filo durante más tiempo y resisten un uso intensivo, algo esencial para los chefs.

German DIN 1.4116 steel is renowned for its exceptional quality and versatility, making it one of the preferred materials in knife making.

Its balanced composition offers superior resistance to wear and oxidation, which means it holds its edge longer and withstands intensive use - essential for chefs.



FILO: Afilado en "V" para una mejor precisión en el corte.

EDGE: With "V"-grind for a finer cut.

HOJA: Fabricado con acero alemán de alta calidad: DIN1.4116 HRC55 ± 2.

BLADE: Made with high-quality German steel: DIN1.4116 HRC55 ± 2.

Proceso de endurecimiento de la hoja en frío para un afilado duradero y resistente al óxido.

Cold-hardened blade for a long-lasting, rust-free grind.

REFUERZO: Cabezal cónico para un agarre cómodo y seguro.

REINFORCEMENT: Cone-shaped bolster for a comfortable, secure grip.

MANGO: Diseño ergonómico para un mejor agarre, proporcionando el equilibrio perfecto en la sujeción del cuchillo.

HANDLE: Ergonomically designed for better grip, giving perfect balance in the hand.



Remaches resistentes a la corrosión. Fabricado en ABS, le proporciona una mayor dureza y una alta resistencia al calor.

Rust-resistant rivets. Made from boron steel which makes it tougher and more heat resistant.

Talón acabado en acero inoxidable que proporciona protección y mayor robustez al mango.

Butt finished in stainless steel to provide protection and make the handle more durable.

Cocina / Kitchen
MARBLE COLLECTION

ACERO:
GERMAN
STEEL
DIN 1.4116

DUREZA:
HRC55 ±2



Cuchillo chef 20
Chef knife 20
Couteau de cuisine 20
Coltello chef 20
Kochmesser 20

| REF. | HOJA (mm) | L (mm) | € | UE / MOQ |
|------|-----------|--------|---|--------------------|
| 8108 | 200/8" | 320 | | 1-6-36-144-432 / 6 |



Cuchillo chef 25
Chef knife 25
Couteau de cuisine 25
Coltello chef 25
Kochmesser 25

| REF. | HOJA (mm) | L (mm) | € | UE / MOQ |
|------|-----------|--------|---|--------------------|
| 8117 | 250/10" | 380 | | 1-6-36-216-432 / 6 |



Cuchillo mini Santoku
Mini Santoku knife
Couteau mini Santoku
Coltello mini Santoku
Mini Santoku-Messer

| REF. | HOJA (mm) | L (mm) | € | UE / MOQ |
|------|-----------|--------|---|--------------------|
| 8112 | 115/4,5" | 230 | | 1-6-48-288-576 / 6 |

Corte / Cuchillos de cocina
Cutting / Kitchen knives



Cuchillo verduras
Utility knife
Couteau à légumes
Coltello multiuso
Universalmesser

| REF. | HOJA (mm) | L (mm) | € | UE / MOQ |
|------|-----------|--------|---|--------------------|
| 8113 | 125/5" | 230 | | 1-6-48-288-576 / 6 |



Cuchillo fileteador
Carving knife
Couteau à filet
Coltello per affettare
Tranchiermesser

| REF. | HOJA (mm) | L (mm) | € | UE / MOQ |
|------|-----------|--------|---|--------------------|
| 8109 | 200/8" | 320 | | 1-6-36-144-432 / 6 |



Cuchillo panero
Bread knife
Couteau à pain
Coltello pane
Brotmesser

| REF. | HOJA (mm) | L (mm) | € | UE / MOQ |
|------|-----------|--------|---|--------------------|
| 8110 | 200/8" | 320 | | 1-6-36-144-432 / 6 |



Cuchillo chuletero
Steak knife
Couteau à steak
Coltello per bistecca
Steakmesser

| REF. | HOJA (mm) | L (mm) | € | UE / MOQ |
|------|-----------|--------|---|--------------------|
| 8114 | 115/4,5" | 220 | | 1-6-48-288-576 / 6 |



Cuchillo Mondador
Paring knife
Couteau d'office
Coltello sbucciatore
Schälmesser

| REF. | HOJA (mm) | L (mm) | € | UE / MOQ |
|------|-----------|--------|---|--------------------|
| 8115 | 80/3,5" | 190 | | 1-6-48-288-576 / 6 |



Cuchillo Santoku
Santoku knife
Couteau Santoku
Coltello Santoku
Santoku-Messer

| REF. | HOJA (mm) | L (mm) | € | UE / MOQ |
|------|-----------|--------|---|--------------------|
| 8111 | 165/6,5" | 300 | | 1-6-36-144-432 / 6 |



Cuchillo jamonero
Slicing knife
Couteau à jambon
Coltello da prosciutto
Schinkenmesser

| REF. | HOJA (mm) | L (mm) | € | UE / MOQ |
|------|-----------|--------|---|--------------------|
| 8116 | 260/9,5" | 385 | | 1-6-36-144-432 / 6 |



Cuchillo deshuesador
Boning knife
Couteau de désossage
Coltello disossato
Ausbeinmesser

| REF. | HOJA (mm) | L (mm) | € | UE / MOQ |
|------|-----------|--------|---|--------------------|
| 8118 | 155/7,8" | 280 | | 1-6-36-216-432 / 6 |



Chaira
Sharpening stell
Fusil
Acciaini
Wetzstahl

| REF. | HOJA (mm) | L (mm) | € | UE / MOQ |
|------|-----------|--------|---|--------------------|
| 8119 | 205/7,8" | 325 | | 1-6-36-216-432 / 6 |



ACERO:
AUS8

DUREZA:
HRC 58±2



La colección de cuchillos ZEN está diseñada para perdurar en el tiempo. Se caracteriza por su diseño elegante y minimalista que refleja la estética japonesa convirtiéndola en una pieza tradicional, innovadora e imprescindible para complementar cualquier cocina.

Esta colección es ideal para aquellos que buscan calidad, rendimiento y belleza en una sola herramienta. El filo tiene un excelente afilado que facilita el corte preciso de cualquier ingrediente.

The ZEN knife collection is designed to last over time. It is characterised by its elegant and minimalist design that reflects Japanese aesthetics, making it a traditional, innovative and essential piece to complement any kitchen.

This collection is ideal for those looking for quality, performance and beauty in a single tool. The cutting edge has an excellent sharpness that facilitates the precise cutting of any ingredient.

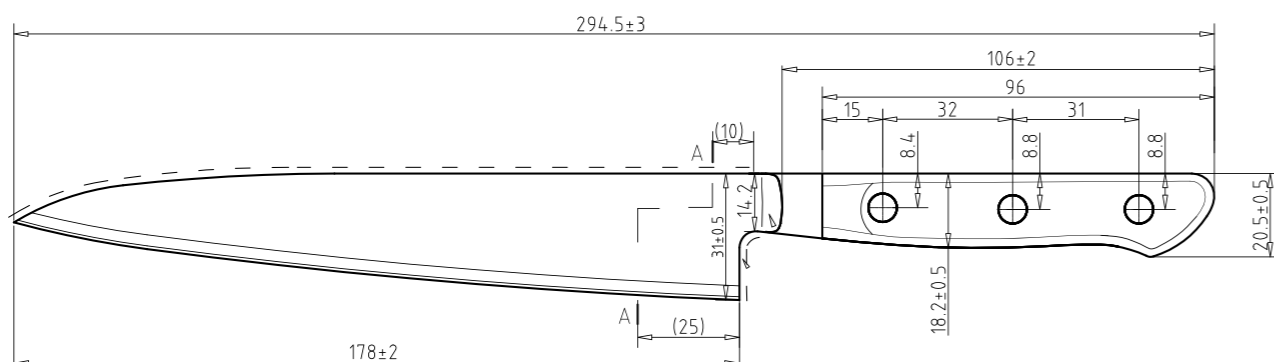

ACERO SAN MAI 3 CAPAS
SAN MAI STEEL 3 LAYERS

Exterior:
Acero inoxidable al cromo 13

Outer layers:
13 chrome stainless steel.

Núcleo:
Acero de aleación (AUS8)

Core: Alloy steel (AUS8)

Diseño ergonómico para un mejor agarre. Acabado suave y satinado.

Ergonomic design for a better grip.

SAN MAI, significa "3 capas" en japonés y es una técnica tradicional de forjado de cuchillos que consiste en la combinación de diferentes tipos de acero con en una estructura laminada, con el fin de aprovechar las mejores características de cada material.

NÚCLEO: El AUS-8 es una opción versátil para los cuchillos de acero inoxidable. Es un acero con un rendimiento sólido.

EXTERIOR: A ambos lados del núcleo encontramos un acero más suave y resistente a la corrosión, protegiendo el núcleo de impactos y roturas.



Afilado en "V" para una mejor precisión en el corte.

With V-grind for a finer cut.

Viola 18/0 con estructura de espiga completa.

18/10 Ferrule full tang structure.

SAN MAI, which means '3 layers' in Japanese, is a traditional knife forging technique that consists of combining different types of steel in a laminated structure, in order to take advantage of the best characteristics of each material.

CORE: AUS-8 is a versatile choice for stainless steel knives. It is a steel with a solid performance.

EXTERIOR: On both sides of the core is a softer, corrosion resistant steel, protecting the core from impact and breakage.



Cuchillo santoku
Santoku zen knife
Couteau santoku
Coltello santoku
Santoku-Messer

| REF. | HOJA (mm) | L (mm) | € | UE / MOQ |
|-------|-----------|--------|---|--------------|
| 10968 | 165 | 295 | | 1-6-36-0-0/1 |



Cuchillo puntilla
Peeling knife
Couteau éplucheur
Coltello da cucina professionale
Schälmesser

| REF. | HOJA (mm) | L (mm) | € | UE / MOQ |
|-------|-----------|--------|---|--------------|
| 10964 | 90 | 205 | | 1-6-36-0-0/1 |



Cuchillo fileteador
Slice knife
Couteau tranche
Coltello fetta
Tranchiermesser

| REF. | HOJA (mm) | L (mm) | € | UE / MOQ |
|-------|-----------|--------|---|--------------|
| 10966 | 180 | 290 | | 1-6-36-0-0/1 |



Cuchillo verduras
Vegetable knife
Couteau à légumes
Coltello per verdure
Gemüsemesser

| REF. | HOJA (mm) | L (mm) | € | UE / MOQ |
|-------|-----------|--------|---|--------------|
| 10965 | 145 | 275 | | 1-6-36-0-0/1 |



Cuchillo chef
Chef's knife
Couteau chef
Coltello chef
Küchenmesser

| REF. | HOJA (mm) | L (mm) | € | UE / MOQ |
|-------|-----------|--------|---|--------------|
| 10967 | 210 | 335 | | 1-6-36-0-0/1 |



Cuchillo nakiri
Nakiri knife
Couteau nakiri
Coltello nakiri
Nakiri messer

| REF. | HOJA (mm) | L (mm) | € | UE / MOQ |
|-------|-----------|--------|---|--------------|
| 10969 | 165 | 295 | | 1-6-36-0-0/1 |



Cuchillo fileteador
Sharpening stell
Fusil
Acciaini
Tranchiermesser

| REF. | HOJA (mm) | L (mm) | € | UE / MOQ |
|-------|-----------|--------|---|--------------|
| 10970 | 240 | 365 | | 1-6-36-0-0/1 |

Cuchillo chef
Chef's knife
Couteau chef
Coltello chef
Küchenmesser



| REF. | HOJA (mm) | L (mm) | € | UE / MOQ |
|-------|-----------|--------|---|---------------|
| 11022 | 210MM | 365 | | 1-0-0-0-0 / 1 |

Cuchillo fileteador
Carving knife
Couteau à filet
Coltello sfilettatore
Filetirmesser



| REF. | HOJA (mm) | L (mm) | € | UE / MOQ |
|-------|-----------|--------|---|---------------|
| 11605 | 235MM | 385MM | | 1-0-0-0-0 / 1 |

Cuchillo Puntilla
Paring Knife
Couteau À Pointe
Coltello Da Cucina Professionale
Ausbeinmesser



| REF. | HOJA (mm) | L (mm) | € | UE / MOQ |
|-------|-----------|--------|---|---------------|
| 11024 | 100MM | 213MM | | 1-0-0-0-0 / 1 |

Cuchillo Fileteador
Carving Knife
Couteau À Filet
Coltello Sfilettatore
Filetirmesser



| REF. | HOJA (mm) | L (mm) | € | UE / MOQ |
|-------|-----------|--------|---|---------------|
| 11023 | 180MM | 320MM | | 1-0-0-0-0 / 1 |

Cuchillo Kiritsuke
Kiritsuke Knife
Couteau Kiritsuke
Coltello Kiritsuke
Kiritsuke-Messer



| REF. | HOJA (mm) | L (mm) | € | UE / MOQ |
|-------|-----------|--------|---|---------------|
| 11606 | 170MM | 313MM | | 1-0-0-0-0 / 1 |



PIN
Mosaico de la familia UTSET con sus cuatro puntos generacionales.

Mosaic of the UTSET family with its four generational points.



PACKAGING BOX



HOJA / BLADE
Acero japonés
SANMAI AUS10
Dureza 60 1 HRC

Japanese steel
SANMAI AUS10
Hardness 60 1 HRC

VIROL / FERRULE
Diseñada para distintos agarres.
Anillo de raíz estabilizada.

Designed for different grips. stabilized root ring.

MANGO / HANDLE
Cuerpo de madera de ébano.

Ebony wood body.

El acero japonés AUS10 destaca como una opción versátil y de alta calidad entre los aceros japoneses para cuchillos.

Con una dureza notable que oscila entre 58 y 60 HRC y un contenido en cromo de aproximadamente el 13%, este acero ofrece una excelente resistencia a la corrosión, garantizando una larga durabilidad y rendimiento.

Japanese AUS10 stands out as a versatile and high quality choice among Japanese knife steels.

With a remarkable hardness ranging from 58 to 60 HRC and a chromium content of approximately 13%, this steel offers excellent corrosion resistance, ensuring long durability and performance.

Cuchillo Panero
Bread knife
Couteau à pain
Coltello da pane
Brotmesser

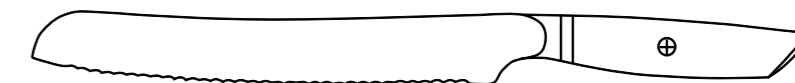

| REF. | HOJA (mm) | L (mm) | € | UE / MOQ |
|-------|-----------|--------|---|---------------|
| 12020 | 235MM | 385MM | | 1-0-0-0-0 / 1 |

Tenedor Trinchador
Carving fork
Fourchette à découper
Forchetta da intaglio
Tranchiergabel



| REF. | HOJA (mm) | L (mm) | € | UE / MOQ |
|-------|-----------|--------|---|---------------|
| 12021 | 160MM | 306MM | | 1-0-0-0-0 / 1 |

ACERO JAPONÉS:
 52100
 HOJA ENNEGRECIDA

DUREZA:
 62 ± 2 HRC



Acero de carbono

El 52100 es un acero al cromo con alto contenido en carbono que ha ganado popularidad en el mundo de la cuchillería para hojas de alto rendimiento.

Conocido por su excepcional dureza, resistencia al desgaste y retención del filo, se utiliza a menudo en cuchillos personalizados de gama alta que requieren una durabilidad superior.

Al ser un cuchillo no inoxidable, se le ha aplicado una pátina negra en toda la hoja para evitar que se oxide fácilmente. Aún así aconsejamos lavarlo siempre a mano y secarlo rápido.

Si se guarda durante tiempo es aconsejable untar de aceite mineral la hoja y la espiga así como guardarlo protegido con funda o saya.

Carbon steel

52100 is a high-carbon chrome steel that has gained popularity in the world of high-performance knife making.

Known for its exceptional hardness, wear resistance and edge retention, it is often used in high-end custom knives that require superior durability.

As a non-stainless knife, a black patina has been applied to the entire blade to prevent it from rusting easily. Even so, we advise to always wash it by hand and dry it quickly.

If it is stored for a long time, it is advisable to smear mineral oil on the blade and tang and to keep it protected with a saya.



Raíz de abedul estabilizada

El mango, de raíz de abedul estabilizada proporciona a la colección la elegancia de una madera noble.

El proceso de estabilización protege y sella la porosidad de la madera para garantizar una mayor durabilidad y resistencia, además de resultar muy agradable al tacto.

Aún siendo un material duradero y resistente es importante evitar el lavavajillas y mantener siempre el cuchillo seco.

Stabilised birch root

The handle, made of stabilised birch root, gives the collection the elegance of a noble wood.

The stabilisation process protects and seals the porosity of the wood to ensure greater durability and strength, as well as being very pleasant to the touch.

Yet being a durable and resistant material, it is important to avoid dishwashing and to always keep the knife dry.



PACKAGING BOX

Conoce UTSET en la página: 494
 More about UTSET in page: 494



KISSAKI

La punta de la hoja. Puede variar de forma según el tipo de cuchillo. Se utiliza el realizar cortes en carnes y pescado o en esculpir verduras

The tip of the blade. It can vary in shape depending on the type of knife. Used for cutting meat and fish or carving vegetables.

HASAKI

Parte afilada que se convierte en el filo del cuchillo.

The sharp part that becomes the cutting edge of the knife.

Hoja fabricada con acero al carbono, conocido por su capacidad de mantener un filo excepcional y su facilidad para ser afilados.

Blade made of carbon steel, known for its ability to maintain an exceptional sharpness and ease of sharpening.

HAMOTO

Parte del filo cerca del mango. Al cortar pescado crudo para hacer sashimi, normalmente se corta desde el hamoto.

Part of the blade near the handle. When cutting raw fish for sashimi, it is usually cut from the hamoto.

KIREHA

Parte final de la hoja, normalmente con forma curva para facilitar el agarre del cuchillo.

The end of the blade, usually curved to make it easier to grip the knife.

PASADOR PIN MOSAICO

Con 4 puntos de acero que representan las 4 generaciones con 130 años de experiencia y pasión por los cuchillos

With 4 steel points representing the 4 generations with 130 years of experience and passion for knives.

MINE

Columna vertebral de la hoja. Parte opuesta al filo.

Spine of the blade. The part opposite the blade.

AGO

Parte más ancha y gruesa de la hoja. Se usa para tareas que requieren más precisión, como cortar alimentos más duros.

The wider, thicker part of the blade. Used for tasks requiring more precision, such as cutting harder foods.

E

Cuerpo principal del mango.

Main body of the handle.

Mango fabricado con raíz de abedul estabilizada. Muy agradable al tacto y mucho más resistente al lavado.

Handle made of stabilised birch root. Very pleasant to the touch and much more resistant to washing.



Cuchillo Chef
 Chef's knife
 Couteau chef
 Coltello chef
 Küchenmesser



| REF. | HOJA (mm) | L (mm) | € | UE / MOQ |
|-------|-----------|--------|---|---------------|
| 11608 | 215MM | 351MM | | 1-0-0-0-0 / 1 |

Cuchillo Fileteador
 Slicer
 Couteau à filet
 Coltello sfilettatore
 Filetiermesser



| REF. | HOJA (mm) | L (mm) | € | UE / MOQ |
|-------|-----------|--------|---|---------------|
| 11609 | 185MM | 312MM | | 1-0-0-0-0 / 1 |

Cuchillo Puntilla
 Utility knife
 Couteau à pointe
 Coltello da cucina
 Ausbeinmesser



| REF. | HOJA (mm) | L (mm) | € | UE / MOQ |
|-------|-----------|--------|---|---------------|
| 11610 | 100MM | 212MM | | 1-0-0-0-0 / 1 |

Cuchillo Fileteador
 Slicer
 Couteau à filet
 Coltello sfilettatore
 Filetiermesser



| REF. | HOJA (mm) | L (mm) | € | UE / MOQ |
|-------|-----------|--------|---|---------------|
| 11657 | 235MM | 367MM | | 1-0-0-0-0 / 1 |

Cuchillo Kiritsuke
 Kiritsuke knife
 Couteau Kiritsuke
 Coltello Kiritsuke
 Kiritsuke-Messer



| REF. | HOJA (mm) | L (mm) | € | UE / MOQ |
|-------|-----------|--------|---|---------------|
| 11658 | 170MM | 300MM | | 1-0-0-0-0 / 1 |

Cuchillo Verduras
 Petty knife
 Couteau à légumes
 Coltello per verdure
 Gemüsemesser



| REF. | HOJA (mm) | L (mm) | € | UE / MOQ |
|-------|-----------|--------|---|---------------|
| 11659 | 150MM | 265MM | | 1-0-0-0-0 / 1 |

Cuchillo Santoku
 Santoku Knife
 Couteau Santoku
 Coltello Santoku
 Santoku-Messer



| REF. | HOJA (mm) | L (mm) | € | UE / MOQ |
|-------|-----------|--------|---|---------------|
| 11660 | 170MM | 302MM | | 1-0-0-0-0 / 1 |



Funda Saya Madera
 Saya wooden sheath
 Étui en bois saya
 Custodia saya in legno
 Holzkiste saya

| REF. | CUCHILLO / KNIFE | L (mm) | € | UE / MOQ |
|-------|------------------|--------|---|------------------|
| 11083 | CHEF | 215 | | 1-12-120-0-0 / 1 |
| 11084 | FILETEADOR | 185 | | 1-12-120-0-0 / 1 |
| 11085 | PUNTILLA | 150 | | 1-12-120-0-0 / 1 |
| 11086 | FILETEADOR | 235 | | 1-12-120-0-0 / 1 |
| 11087 | KIRITSUKE | 170 | | 1-12-120-0-0 / 1 |
| 11088 | VERDURAS | 150 | | 1-12-120-0-0 / 1 |
| 11661 | SANTOKU | 170 | | 1-12-120-0-0 / 1 |



Madera de acacia de alta calidad.

High quality acacia wood.

4 lados magnéticos.

4 magnetic sides.

Base de acero inoxidable con almohadillas antideslizantes.

Stainless steel base with non-slip pads.

Giratorio 360°

360° rotatable



NEW

Iman Taco Rotable Cuchillos
Rotating Magnet Knife Display
Aimant Taco Rotatif Pour Couteaux
Barra Magnetica Taco Rotabile Coltelli
Drehbarer Tischmagnet für Messer



| REF. | L(mm) | W(mm) | H(mm) | € | UE / MOQ |
|-------|-------|-------|-------|-------|---------------|
| 11636 | 105 | 105 | 280 | 55,70 | 1-0-4-0-0 / 1 |



NEW

Iman Sobremesa Cuchillos
Tabletop Magnet Knife Display
Aimant De Table Pour Couteaux
Barra Magnetica Portacoltelli
Tischmagnet für Messer



| REF. | L(mm) | W(mm) | H(mm) | € | UE / MOQ |
|-------|-------|-------|-------|-------|---------------|
| 11038 | 90 | 280 | 245 | 51,56 | 1-0-5-0-0 / 1 |

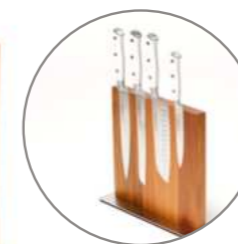

NEW

Expositor Madera Cuchillo Chef
Wooden Chef'S Knives Display
Présentoir En Bois Pour Couteau De Chef
Espositore In Legno Coltelli Chef
Messerhalter für Küchenmesser



| REF. | L(mm) | W(mm) | H(mm) | € | UE / MOQ |
|-------|-------|-------|-------|---|----------------|
| 11637 | 340 | 80 | 180 | | 1-0-10-0-0 / 1 |





Imán pared madera
Wooden wall magnet
Porte-couteaux magnetic
Barra magnetica legno
Magnetleiste für Messer Holz



| REF. | L(mm) | H(mm) | € | UE / MOQ |
|------|-------|-------|---|------------------|
| 8471 | 460 | 67 | | 1-0-8-88-264 / 6 |



Imán pared inox
Magnetic bar inox
Porte-couteaux magnetic inox
Barra magnetica inox
Magnetleiste für Messer inox



| REF. | L(mm) | H(mm) | € | UE / MOQ |
|------|-------|-------|---|-------------------|
| 8470 | 350 | 47 | | 1-6-8-144-288 / 6 |



Imán pared PP
PP magnetic bar
Porte-couteaux magnetic PP
Barra magnetica PP
Magnetleiste für Messer PP



| REF. | L(mm) | H(mm) | € | UE / MOQ |
|------|-------|-------|---|--------------------|
| 8472 | 550 | 50 | | 1-6-12-108-432 / 6 |



Madera de acacia de alta calidad.

High quality acacia wood.

Tratada con aceites naturales para resaltar su color y protegerla de la humedad.

Treated with natural oils to enhance its colour and protect it from moisture.

Grosor considerable para mayor durabilidad y estabilidad.

Substantial thickness for durability and stability.

Corte / Accesorios de corte
Cutting / Cutting accessories

El patrón de bolques END GRAIN ofrece mayor resistencia al desgaste y menor daño a los cuchillos.

The END GRAIN bolt pattern offers greater wear resistance and less damage to knives.



Hendiduras laterales para el agarre. Facilitan el levantamiento y transporte, incluso cargada con alimentos.

Side grooves for gripping and easy lifting and transport, even when loaded with foodstuffs.

Tacos de goma antideslizantes. Colocados en las esquinas, evitan que la tabla se deslice durante su uso, proporcionando estabilidad.

Non-slip rubber pads on the corners prevent the board from slipping during use and provide stability.

NEW

Tabla madera acacia
Acacia wood board
Planche en bois d'acacia
Tavola in legno di acacia
Akazienholzplatte



| REF. | W(mm) | L(mm) | H(mm) | € | UE / MOQ |
|-------|-------|-------|-------|---|-----------|
| 12034 | 400 | 320 | 38 | | 1-0-0 / 1 |

Ideal para mantener la piedra fija durante el proceso de afilado.

Ideal for holding the stone in place during the sharpening process.

Soporte de caucho ajustable a distintos tamaños de piedras.

Adjustable rubber support for different stone sizes.

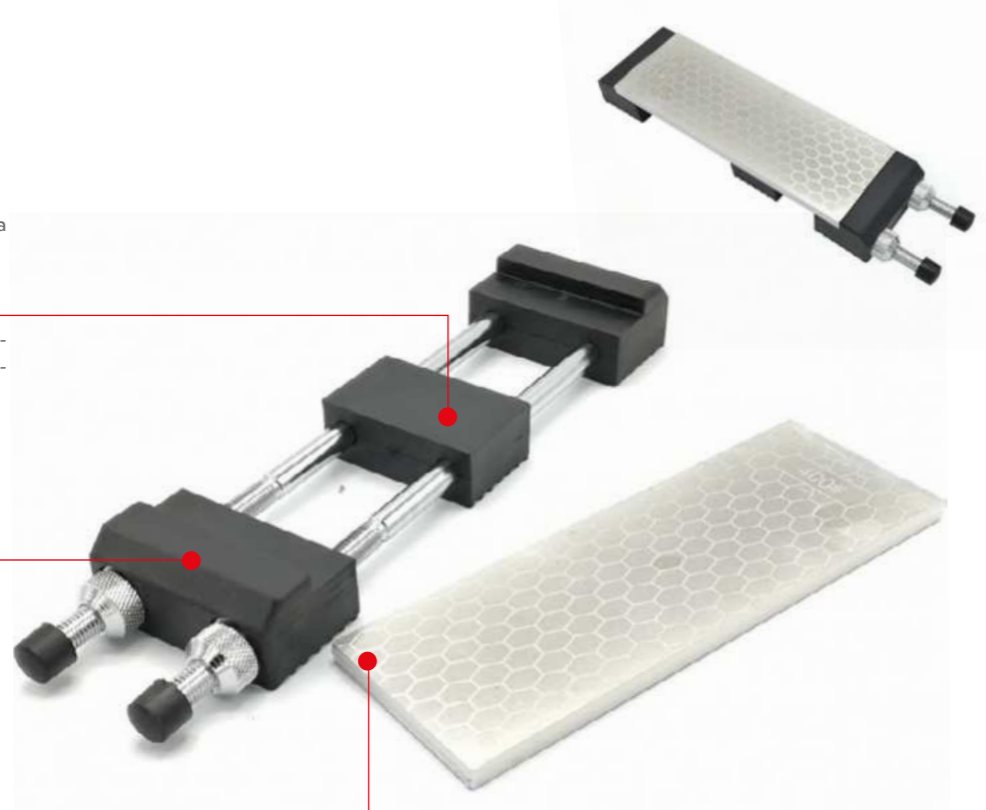

Placa diamantada de doble cara (grano 400 / 1000) y doble función: reparación de hojas dañadas y realizar un filo completamente nuevo. También la podemos usar para aplanar y limpiar las piedras de afilar usadas.

Double-sided diamond plate (grit 400/1000) with double function: repairing damaged blades and making a completely new cutting edge. It can also be used to flatten and clean used whetstones.

NEW

Placa diamantada para afilado con soporte

Diamond encrusted sharpening and levelling stone with stand
Plaque diamantée pour affûtage et aplatissage avec support
Piastra diamantata per affilare e appiattare con supporto
Diamantschleifstein mit Haltern

| REF. | L(mm) | W(mm) | H(mm) | € | UE / MOQ |
|-------|-------|-------|-------|---|----------------|
| 11939 | 286 | 70 | 30 | | 1-0-10-0-0 / 1 |

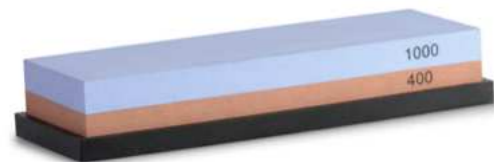

Piedra afilar
Whetstone
Pierre à aiguiser
Cote
Schärfstein Messer

| REF. | L(mm) | € | UE / MOQ |
|------|-------|---|--------------------|
| 6958 | 180 | | 1-0-16-176-528 / 2 |



Afilador mango
Two stage knife sharpener
Affûteur couteau
Arrotino
Messerschärfer mit Griff

| REF. | L(mm) | € | UE / MOQ |
|------|-------|---|--------------------|
| 6957 | 190 | | 1-0-36-180-360 / 6 |



Puente bambú piedra afiladora

Bamboo sharpening stone
Pierre à aiguiser en bambou
Pietra per affilare in bambù
Schärfstein aus bambus

* No incluye piedra de afilar
Sharpening stone not includes

| REF. | L(mm) | W(mm) | H(mm) | € | MOQ |
|-------|-------|-------|-------|---|---------------|
| 11029 | 430 | 100 | 90 | | 1-0-0-0-0 / 1 |



Piedra de afilar 1000

Sharpening stone 1000
Pierre a aiguiser 1000
Pietra per affilare 1000
Schärfstein 1000

| REF. | L(mm) | W(mm) | H(mm) | € | MOQ |
|-------|-------|-------|-------|---|---------------|
| 11031 | 210 | 70 | 25 | | 1-0-0-0-0 / 1 |



Piedra de afilar 5000

Sharpening stone 5000
Pierre a aiguiser 5000
Pietra per affilare 5000
Schärfstein 5000

| REF. | L(mm) | W(mm) | H(mm) | € | MOQ |
|-------|-------|-------|-------|---|---------------|
| 11033 | 210 | 70 | 25 | | 1-0-0-0-0 / 1 |



Asentador

Strop
Strop
Strop
Strop

| REF. | L(mm) | W(mm) | H(mm) | € | MOQ |
|-------|-------|-------|-------|---|---------------|
| 11037 | 350 | 80 | 45 | | 1-0-0-0-0 / 1 |



Piedra de afilar 400

Sharpening stone 400
Pierre a aiguiser 400
Pietra per affilare 400
Schärfstein 400

| REF. | L(mm) | W(mm) | H(mm) | € | MOQ |
|-------|-------|-------|-------|---|---------------|
| 11030 | 210 | 70 | 25 | | 1-0-0-0-0 / 1 |



Piedra de afilar 3000

Sharpening stone 3000
Pierre a aiguiser 3000
Pietra per affilare 3000
Schärfstein 3000

| REF. | L(mm) | W(mm) | H(mm) | € | MOQ |
|-------|-------|-------|-------|--------|---------------|
| 11032 | 210 | 70 | 25 | 139,50 | 1-0-0-0-0 / 1 |



Placa acero diamantada

Diamond steel plate
Plaque en acier diamant
Piastra in acciaio diamantato
Diamant-stahlplatte

| REF. | L(mm) | W(mm) | H(mm) | € | MOQ |
|-------|-------|-------|-------|---|---------------|
| 11034 | 203 | 76 | 10 | | 1-0-0-0-0 / 1 |

Conoce UTSET en la página: 494
More about UTSET in page: 494

El maletín es la mejor opción para mantener tus cuchillos organizados y con el filo protegido para un afilado duradero.

The Knife roll is the best option to keep your knives organised and edge protected for long-lasting sharpness

La manera más segura de transportar tu selección de cuchillos donde necesites.

The safest way to transport your knife selection wherever you need it.

2 cierres de plástico de alta seguridad

2 high-security plastic closures

Tela adicional con cremallera para proteger los cuchillos

The long cuffs provide extra protection for your forearms.

Bolsillos con banda elástica para sujetar los cuchillos con seguridad.

Pockets with elastic band to hold knives securely.

Asa de mano + tira ajustable para colgar para un transporte más práctico.

Hand grip handle + adjustable hanging strap for convenient carrying.

Bolsa Porta Cuchillos
Knife roll
Sac porte-couteaux
Borsa portacoltelli
Tragebeutel für messer

| REF. | L(mm) | W(mm) | H(mm) | € | UE / MOQ |
|-------|-------|-------|-------|---|--------------|
| 11035 | 520 | 60 | 200 | | 1-0-10-0-0/1 |



NEW

Funda Protectora Abs

Abs protective sheath
Étui de protection abs
Custodia protettiva In plastica
Schutzhülle abs

| REF. | MEDIDAS / SIZES | € | UE / MOQ |
|-------|-----------------|---|-----------------|
| 11734 | 120 x 35 mm | | 1-30-240-0-0 /1 |
| 11735 | 160 x 35 mm | | 1-30-240-0-0 /1 |
| 11736 | 200 x 55 mm | | 1-30-240-0-0 /1 |
| 11737 | 240 x 65 mm | | 1-30-240-0-0 /1 |
| 11738 | 270 x 55 mm | | 1-30-240-0-0 /1 |

Tejido de Nylon resistente que protege los cuchillos de golpes y evita pinchazos y cortes.

Durable nylon fabric protects knives from knocks and prevents punctures and cuts.

Incluye maletín con compartimentos específicos para utensilios de cocina.

Includes case with specific compartments for kitchen utensils.



NEW

Mochila chef con maletín portacuchillos

Chef backpack with knife holder case
Sac à dos de chef avec étui porte-couteaux
Zaino da chef con custodia portacoltelli
Kochrucksack mit Messerhalteretui

| REF. | L(mm) | W(mm) | H(mm) | € | UE / MOQ |
|-------|-------|-------|-------|---|-------------|
| 12022 | 320 | 140 | 460 | | 1-0-6-0-0/1 |

NEW

Delantal cocina

Kitchen apron
Tablier de cuisine
Crembiule da cucina
Küchenschürze

| REF. | L(mm) | € | UE / MOQ |
|-------|-------|---|---------------|
| 12023 | 180 | | 1-0-12-0-0 /1 |

Acero inoxidable AISI 420-4034

Stainless steel

HRc 56 Rockwell

Microdentada

Micro-Toothed

Forjada en caliente

Hot forged

Diseño ergonómico

Ergonomic design

Todo tipo de alimentos

All types of food



INOX STAINLESS STEEL 420

Tijera profesional 8"
Scissors prof. Inox 8"
Ciseaux prof. Acier 8"
Forbice prof. Acciaio 8"
Stahl prof Schere 8"

| REF. | L(mm) | € | UE / MOQ |
|------|-------|-------|------------------|
| 5164 | 200 | 83,65 | 1-0-6-84-588 / 1 |



INOX STAINLESS STEEL 420

Tijera cocina inox
Kitchen scissors
Ciseaux de cuisine
Forbici cucina
Küchenschere

| REF. | L(mm) | € | UE / MOQ |
|------|-------|---|----------------------|
| 3910 | 220 | | 1-12-48-288-576 / 12 |



Cascañueces
Nut cracker
Case-noix
Rompinoci
Nussknacker



| REF. | L(mm) | € | UE / MOQ |
|------|-------|---|-----------------------|
| 3623 | 160 | | 1-10-50-900-2700 / 10 |

INOX STAINLESS STEEL 304



Tenedor marisco
Shellfish fork
Fourchette crustacé
Forchetta crostacei
Fischgabel

| REF. | L(mm) | € | UE / MOQ |
|------|-------|---|------------------------|
| 5099 | 220 | | 0-12-120-3000-15K / 12 |



INOX STAINLESS STEEL 2Cr14

PP POLYPROPYLENE

Tijera para aves
Poultry shears
Coupe volailles
Trinciapollo
Geflügelschere

| REF. | L(mm) | € | UE / MOQ |
|------|-------|---|--------------------|
| 8989 | 200 | | 1-6-36-216-432 / 6 |



INOX STAINLESS STEEL 3Cr13

NYLON

Tijera cocina 8,5
Kitchen scissors 8,5
Ciseaux cuisine 8,5
Forbice multiuso 8,5
Küchenschere 8,5

| REF. | L(mm) | € | UE / MOQ |
|------|-------|---|----------------------|
| 8988 | 210 | | 1-12-96-576-576 / 12 |



Pinza rompe marisco
Lobster cracker
Pince homard
Pinza per aragosta
Hummerkuacker



| REF. | L(mm) | € | UE / MOQ |
|------|-------|---|----------------------|
| 0738 | 190 | | 1-5-50-350-1400 / 12 |



NEW

Pinza marisco
Shellfish cracker
Pince à fruits de mer
Pinza per frutti di mare
Schalentier-pinzette



| REF. | L(mm) | € | UE / MOQ |
|-------|-------|---|-------------|
| 11827 | 190 | | 1-12-96 / 1 |



INOX STAINLESS STEEL 420

Tijera master 8"
Scissors master inox 8"
Ciseaux master acier 8"
Forbice master acciaio 8"
Stahl Maister Schere 8"

| REF. | L(mm) | € | UE / MOQ |
|------|-------|---|------------------|
| 5165 | 200 | | 1-0-6-84-588 / 1 |





Regulador de grueso del corte.

Cutting thickness regulator.

Soporte para sujeción de verduras y frutas con protección para los dedos.

Vegetable and fruit holder with finger protection.

Pies plegables y antideslizantes.

Foldable, non-slip feet.



CUCHILLA / BLADE:
RODAJAS

CUCHILLA / BLADE:
JULIANA 4MM

CUCHILLA / BLADE:
JULIANA 6MM

CUCHILLA / BLADE:
JULIANA 10MM

CUCHILLA / BLADE:
GOFRADO



Mandolina Inox
Stainless Steel Mandoline
Mandoline Inox
Mandolina Inox
Edelstahl Mandoline



| REF. | L(mm) | W(mm) | H(mm) | € | UE / MOQ |
|-------|-------|-------|-------|---|---------------|
| 11748 | 395 | 123 | 42 | | 1-0-6-0-0 / 1 |



Corte / Ralladores profesionales
Cutting / Professional graters



Rallador WIDE extra fino
St. Steel "wide" grater extra-thin
Râpe en inox coupe ultra fine
Grattugia taglio superfine
Breit rostfreie Reibe extra fein

| REF. | L HOJA | L TOTAL | € | UE / MOQ |
|------|--------|---------|---|--------------------|
| 8946 | 135 | 320 | | 1-6-96-576-576 / 6 |

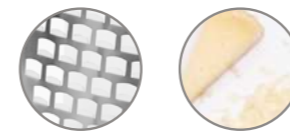

Rallador WIDE grueso
St. Steel "wide" grater extra coarse
Râpe en inox coupe épaisse
Grattugia taglio spesso
Breit rostfreie Reibe grob

| REF. | L HOJA | L TOTAL | € | UE / MOQ |
|------|--------|---------|---|--------------------|
| 8948 | 135 | 320 | | 1-6-96-576-576 / 6 |



Rallador SLIM fino
St. Steel lengthways grater thin
Râpe longue en inox coupe fine
Grattugia lunga taglio fine
Schmal rostfreie Reibe fein

| REF. | L HOJA | L TOTAL | € | UE / MOQ |
|------|--------|---------|---|--------------------|
| 8950 | 220 | 410 | | 1-6-96-576-576 / 6 |



Rallador SLIM grueso
St. Steel lengthways grater extra coarse
Râpe longue en inox coupe épaisse
Grattugia lunga taglio spesso
Schmal rostfreie Reibe grob

| REF. | L HOJA | L TOTAL | € | UE / MOQ |
|------|--------|---------|---|--------------------|
| 8952 | 220 | 410 | | 1-6-96-576-576 / 6 |

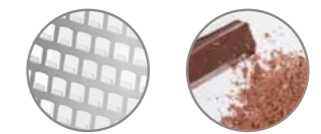

Rallador WIDE fino
St. Steel "wide" grater thin
Râpe en inox coupe fine
Grattugia taglio fine
Breit rostfreie Reibe fein

| REF. | L HOJA | L TOTAL | € | UE / MOQ |
|------|--------|---------|---|----------------------|
| 8947 | 135 | 320 | | 1-6-96-0-576-576 / 6 |

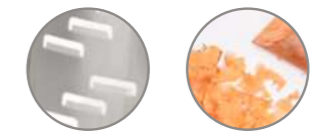

Rallador WIDE tiras largas
St. Steel "wide" grater large shaver
Râpe en inox coupe julienne
Grattugia taglio julienne
Breit rostfreie Reibe mit lange

| REF. | L HOJA | L TOTAL | € | UE / MOQ |
|------|--------|---------|---|--------------------|
| 8949 | 135 | 320 | | 1-6-96-768-768 / 6 |

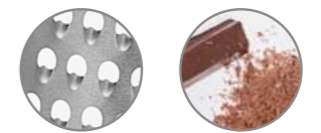

Rallador SLIM medio redondo
St. Steel lengthways grater medium
Râpe longue en inox coupe redondo moyen
Grattugia lunga taglio mezzo giro
Schmal rostfreie Reibe medium

| REF. | L HOJA | L TOTAL | € | UE / MOQ |
|------|--------|---------|---|--------------------|
| 8951 | 220 | 410 | | 1-6-96-576-576 / 6 |

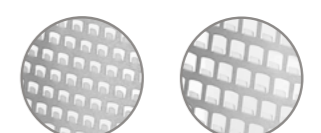

Rallador SLIM dual
St. Steel lengthways grater dual
Râpe longue en inox coupe dual
Grattugia lunga taglio dual
Duale schmal rostfreie Reibe

| REF. | L HOJA | L TOTAL | € | UE / MOQ |
|------|--------|---------|---|--------------------|
| 8953 | 220 | 410 | | 1-6-96-576-576 / 6 |

Se presenta con una funda de plástico para proteger la zona de corte

Comes with a plastic sheath to protect the cutting edge

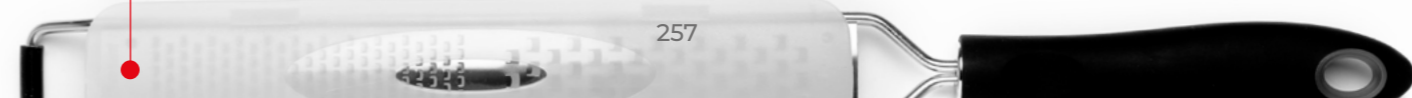

Mango ergonómico

Ergonomic handle

INOX
STAINLESS
STEEL
430

Acero inoxidable resistente al desgaste y la corrosión.

Wear and corrosion resistant stainless steel.



Grueso
Coarse

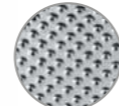

Fino
Fine

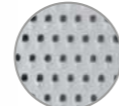

Medio
Medium



Rebanador
Slicer

Rallador 4 caras HQ

4 side grater HQ
Rape 4 cotés HQ
Grattugia 4 facce HQ
Vierkantreibe HQ

| REF. | H(mm) | € | UE / MOQ |
|------|-------|------|---------------------|
| 7448 | 240 | 7,32 | 1-12-72-288-288 / 6 |

INOX
STAINLESS
STEEL
201

Rallador 4 caras

4 side grater
Râpe 4 faces
Grattugia 4 lam.
Vierkantreibe

| REF. | H(mm) | € | UE / MOQ |
|------|-------|---|---------------------|
| 1150 | 210 | | 1-0-60-720-2160 / 6 |



NEW

Abrelatas Inox

Stainless Steel Tin Opener
Ouvre-Boîte Inox
Apriscatole In Acciaio Inox
Dosenöffner Edelstahl



| REF. | L(mm) | W(mm) | H(mm) | € | UE / MOQ |
|-------|-------|-------|-------|---|----------------|
| 11818 | 65 | 45 | 28 | | 1-0-96-0-0 / 1 |

INOX
STAINLESS
STEEL
430

Pelapatatas

Potato-peeler
Économe acier inox
Pelapatate
Kartoffelschäler



| REF. | L(mm) | € | UE / MOQ |
|------|-------|---|--------------------|
| 3455 | 110 | | 1-12-12-36-72 / 12 |



Rasqueta plancha profesional 30cm

Professional scraper
Racleur professionnelle
Raschietti
Schaber glatt

| REF. | L(mm) | € | UE / MOQ |
|------|-------|---|-----------------------|
| 8474 | 300 | | 1-12-24-288-2016 / 12 |

Recambio 10 cuchillas

Blister 10 blades
Blister 10 lames
Blister 10 lame
Blister 10 messer



| REF. | € | UE / MOQ |
|------|---|-------------------------|
| 8507 | | 1-50-100-1100-6600 / 10 |

Rodillo de recambio

Wheel (spare part)
Rouleau (pièce de rechange)
Rullo
Austauschrad

| REF. | € | UE / MOQ |
|------|---|-----------------------|
| 8566 | | 1-0-200-3000-9000 / 1 |

Cuchilla de recambio

Knife (spare part)
Couteau (pièce de rechange)
Lame
Austauschklinge

| REF. | € | UE / MOQ |
|------|---|-----------------------|
| 8565 | | 1-0-200-3000-9000 / 1 |



NEW

Cepillo

Scraper
Brosse À Gratter
Raschietto
Schaber

| REF. | L(mm) | W(mm) | H(mm) | € | UE / MOQ |
|-------|-------|-------|-------|---|---------------|
| 11946 | 470 | 125 | 55 | | 1-0-6-0-0 / 1 |

Recambio Cepillo

Replacement Scraper Brush
Pièce De Recharge Brosse À Gratter
Ricambio Spazzola Raschietto
Ersatzbürste Schaber

| REF. | L(mm) | W(mm) | H(mm) | € | UE / MOQ |
|-------|-------|-------|-------|---|----------------|
| 11947 | 125 | 70 | 17 | | 1-0-24-0-0 / 1 |



Abrelatas industrial

Can opener
Ouvre-boîtes professionnel
Apriscatole
Industrieller edelstahl dosenöffner

| REF. | H(mm) | € | UE / MOQ |
|------|-------|---|-----------------|
| 8564 | 600 | | 1-0-8-16-16 / 1 |



Espátula pastelera
Baker spatula
Palette
Spatola cuoco
Kuchenspachtel

| REF. | SIZE | HOJA (mm) | € | UE / MOQ |
|------|------|-----------|---|-----------------------|
| 8932 | S | 135 | | 1-12-48-576-1152 / 12 |
| 8933 | M | 225 | | 1-12-48-480-960 / 12 |
| 8934 | L | 300 | | 1-12-48-432-864 / 12 |



Pala repostería
Cake server
Pelle à gâteau
Spatola dolci
Kekss-Spachtel

| REF. | W (mm) | € | UE / MOQ |
|------|--------|-------------|-----------------------|
| 8941 | 120 | 2,74 | 1-12-48-384-1152 / 12 |



Espátula flexible acodada
Angular spatula
Palette coudée
Spatola cuoco con scalino
Winkelpalette

| REF. | SIZE | HOJA (mm) | € | UE / MOQ |
|------|------|-----------|---|----------------------|
| 8938 | S | 140 | | 1-12-48-384-768 / 12 |
| 8937 | L | 200 | | 1-12-48-288-864 / 12 |

Mango de polipropileno (PP) de forma redondeada para una sujeción más cómoda.

Rounded polypropylene (PP) handle for a more comfortable grip.

Piezas aptas para lavavajillas.

Dishwasher safe.

Alta resistencia a la corrosión.

Highly rust-resistant.

Pala fabricada en Acero inoxidable endurecido de alta calidad.

Spatula in high-quality hardened stainless steel.

Acabado satinado.

Satin finished.

Resistencia y flexibilidad para facilitar el trabajo en la cocina.

Hard-wearing and versatile round the kitchen.



Espátula plancha rectangular biselada
Solid, beveled turner
Palette pleine, biseautée
Spatola hamburger
Bratenspachtel Rechtechige

| REF. | W (mm) | H (mm) | € | UE / MOQ |
|------|--------|--------|---|----------------------|
| 8935 | 80 | 120 | | 1-12-48-384-768 / 12 |



Paleta plancha triangular
Cleaning spatula
Palette triangle
Spatola triangolare
Dreieckige Bratenspachtel

| REF. | SIZE | HOJA (mm) | € | UE / MOQ |
|------|------|-----------|---|-----------------------|
| 8939 | S | 80 | | 1-12-48-576-1152 / 12 |
| 8940 | L | 100 | | 1-12-48-480-960 / 12 |



Espátula pescado
Fish Spatula
Spatule poisson
Pesce spatola
Fischpachtel

| REF. | W (mm) | L (mm) | € | UE / MOQ |
|------|--------|--------|---|---------------------|
| 9996 | 80 | 290 | | 1-12-48-384-768 / 1 |



Espátula plancha rectangular biselada mango madera
Spatula. Wood handle
Palette. Manche en bois
Spatola hamburger
Bratenwender mit Holzgriff

| REF. | MODELO | W (mm) | L (mm) | € | UE / MOQ |
|------|-------------|--------|--------|---|-----------------------|
| 8942 | RECTANGULAR | 80 | 290 | | 1-12-48-384-768 / 12 |
| 8943 | TRIANGULAR | 80 | 235 | | 1-12-48-384-1920 / 12 |



Espátula pescado biselada
Fish turner
Palette poisson
Spatola pesce
Fischschaufel

| REF. | W (mm) | H (mm) | € | UE / MOQ |
|------|--------|--------|---|----------------------|
| 8936 | 75 | 165 | | 1-12-48-384-768 / 12 |



Espátula angular emplatado
Angular spatula
Mini spatule
Spatola
Kleine Winhelpalette

| REF. | L Total (mm) | Paleta (mm) | € | UE / MOQ |
|------|--------------|-------------|---|-------------------------|
| 8476 | 220 | 95 | | 1-48-288-1728-5184 / 12 |



Mini lengua de silicona
Silicone spoon
Cuillère silicone
Spatola silicone
Silikonlöffel

| REF. | L (mm) | COLOR | € | UE / MOQ |
|------|--------|-------|---|------------------------|
| 5161 | 170 | ROJA | | 1-24-96-1920-5760 / 24 |



PACKAGING
BLISTER



Punta estriada para un mejor agarre de los alimentos
Grooved tip for a better grip of the foods.



Pinza chef recta
Straight chef tong
Pince chef droite
Pinze chef diritta
Pinzettenzange

INOX STAINLESS STEEL 430

| REF. | L(mm) | € | UE / MOQ |
|------|-------|---|-----------------------|
| 7477 | 210 | | 1-24-96-1920-5760 / 6 |
| 7478 | 300 | | 1-24-96-1920-5760 / 6 |



Pinza chef precisión
Precision chef tong
Pince chef précision
Pinze chef precisione
Präzisions-Kochpinzette

INOX STAINLESS STEEL 430

| REF. | L(mm) | € | UE / MOQ |
|------|-------|---|-----------------------|
| 7475 | 160 | | 1-24-96-1920-5760 / 6 |
| 7476 | 240 | | 1-24-96-1920-5760 / 6 |



Pinza chef curva
Curved chef tong
Pince chef courbée
Pinze chef curve
Gebogene Pinzette

| REF. | L(mm) | COLOR | € | UE / MOQ |
|------|-------|-------|---|-----------------------|
| 7473 | 145 | INOX | | 1-24-96-1920-5760 / 6 |
| 7474 | 200 | INOX | | 1-24-96-1920-5760 / 6 |
| 8680 | 200 | ORO | | 1-24-96-1920-5760 / 6 |
| 8681 | 200 | COBRE | | 1-24-96-1920-5760 / 6 |
| 8682 | 200 | NEGRO | | 1-24-96-1920-5760 / 6 |



OPCIÓN DE PERSONALIZACIÓN CON LASER.
LASER PERSONALISATION OPTION



Molde redondo
Round ring
Moulage rond
Teglia tondo
Runckle Kochringe

| REF. | Ø(mm) | H(mm) | € | UE / MOQ |
|------|-------|-------|---|------------------------|
| 7461 | 60 | 45 | | 1-32-128-512-1536 / 12 |
| 7462 | 70 | 45 | | 1-32-128-768-1536 / 12 |
| 7463 | 80 | 45 | | 1-32-128-768-1536 / 12 |
| 7464 | 90 | 45 | | 1-32-128-768-1536 / 12 |
| 7465 | 100 | 45 | | 1-32-128-256-512 / 12 |
| 7466 | 120 | 45 | | 1-32-128-256-512 / 12 |

| REF. | SET | € | UE / MOQ |
|------|--------|---|---------------------|
| 7449 | PACK 6 | | 1-24-48-192-392 / 6 |



Molde cuadrado
Square ring
Moulage carre
Teglia quadrato
Quadratische Kochringe

| REF. | W/L (mm) | H(mm) | € | UE / MOQ |
|------|----------|-------|---|------------------------|
| 7467 | 60x60 | 45 | | 1-32-128-512-1536 / 12 |
| 7468 | 70x70 | 45 | | 1-32-128-768-1536 / 12 |
| 7469 | 80x80 | 45 | | 1-32-128-768-1536 / 12 |
| 7470 | 90x90 | 45 | | 1-32-128-768-1536 / 12 |
| 7471 | 100x100 | 45 | | 1-32-128-768-1536 / 12 |
| 7472 | 120x120 | 45 | | 1-32-128-768-1536 / 12 |

| REF. | SET | € | UE / MOQ |
|------|--------|---|---------------------|
| 7450 | PACK 6 | | 1-24-48-192-392 / 6 |

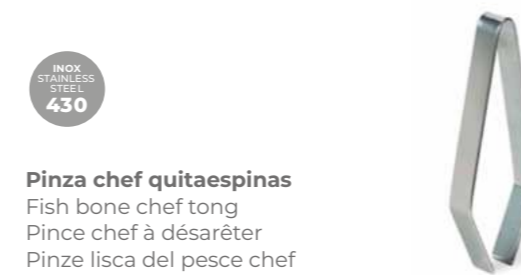

Pinza chef quitaespinas
Fish bone chef tong
Pince chef à désarêter
Pinze lisca del pesce chef
Frischgräten küchenmeister zange

| REF. | L(mm) | € | UE / MOQ |
|------|-------|---|-----------------------|
| 7479 | 120 | | 1-24-96-1920-5760 / 6 |



Pinza quitaespinas
Fish bone tong
Pince à désarêter
Pinze lisca del pesce
Frischgräten pinzette

| REF. | L(mm) | W(mm) | H(mm) | € | UE / MOQ |
|-------|-------|-------|-------|---|------------|
| 11819 | 135 | 19 | 20 | | 1-0-72 / 1 |



Mango con gancho para un fácil almacenamiento.

Hook handle for easy storage



Capacidad grabada en el mango.

Capacity engraved on the handle

Acabado brillo. Menos poroso, facilita la limpieza.

Mirror finish.. Less porous, easier to clean.

Mango más grueso con nervio central que le proporciona más rigidez y resistencia.

Thicker handle with a central rib for more rigidity and stiffens and strengthens the handle.

INOX STAINLESS STEEL 201

Espumadera con malla
Mesh skimmer
Écumoire maillée
Schiumarola a rete passabrodo
Draht Schaumlöffel



| REF. | Ø(mm) | € | UE / MOQ |
|------|-------|---|---------------------|
| 9735 | 140 | | 1-0-50-120-450 / 10 |
| 9736 | 160 | | 1-0-30-120-360 / 10 |
| 9737 | 180 | | 1-0-30-120-360 / 10 |
| 9738 | 200 | | 1-0-30-90-270 / 10 |
| 9739 | 240 | | 1-0-30-90-270 / 10 |

INOX STAINLESS STEEL 430

Cazo Monoblock
One piece laddle
Louche monoblock
Mestolo monoblock
Schöpfhelle monoblock



| REF. | Ø(mm) | L(mm) | ml | € | UE / MOQ |
|------|-------|-------|-----|---|----------------------|
| 9712 | 65 | 300 | 70 | | 1-10-240-720 / 10 |
| 9713 | 80 | 320 | 125 | | 1-6-60-240-480 / 10 |
| 9714 | 90 | 330 | 200 | | 1-10-40-160-480 / 10 |
| 9715 | 100 | 370 | 250 | | 1-10-40-160-320 / 10 |
| 9716 | 120 | 430 | 430 | | 1-10-40-160-320 / 10 |
| 9717 | 140 | 440 | 650 | | 1-10-40-160-320 / 10 |
| 9718 | 160 | 470 | 950 | | 1-10-20-40-160 / 10 |

INOX STAINLESS STEEL 201

Cuchara servir monoblock
One piece spoon
Couliere monoblock
Cucchiaio monoblock
Servierlöffel



| REF. | L(mm) | € | UE / MOQ |
|------|-------|---|----------------------|
| 9726 | 330 | | 1-10-60-120-480 / 10 |

INOX STAINLESS STEEL 201

Tenedor 2 púas monoblock
One piece meat fork
Fourchette monoblock
Forchetta monoblock
Fleischgabel monoblock



| REF. | L(mm) | € | UE / MOQ |
|------|-------|---|-----------------------|
| 9728 | 520 | | 1-20-60-300-1500 / 10 |

INOX STAINLESS STEEL 201

Araña
Tinned skimer
Escumoire etamée
Schiumarola filo
Fritierlöffel



| REF. | Ø(mm) | € | UE / MOQ |
|------|-------|---|---------------------|
| 9729 | 140 | | 1-0-50-200-400 / 10 |
| 9730 | 160 | | 1-0-25-100-200 / 10 |
| 9731 | 180 | | 1-0-25-100-200 / 10 |
| 9732 | 200 | | 1-0-25-100-200 / 10 |
| 9733 | 220 | | 1-0-25-100-200 / 10 |
| 9734 | 240 | | 1-0-25-100-200 / 10 |

INOX STAINLESS STEEL 201

Espumadera Monoblock
One piece skimmer
Écumoire monoblock
Schiumarola monoblock
Schäumerlöffel



| REF. | Ø(mm) | L(mm) | € | UE / MOQ |
|------|-------|-------|---|----------------------|
| 9719 | 80 | 290 | | 1-10-60-240-480 / 10 |
| 9720 | 100 | 320 | | 1-10-60-240-720 / 10 |
| 9721 | 120 | 350 | | 1-10-40-160-480 / 10 |
| 9722 | 140 | 380 | | 1-10-40-160-480 / 10 |
| 9723 | 160 | 410 | | 1-10-40-160-320 / 10 |
| 9724 | 180 | 430 | | 1-10-40-80-240 / 10 |
| 9725 | 200 | 450 | | 1-10-40-80-240 / 10 |

INOX STAINLESS STEEL 201

Espátula perforada
Perforated spatula
Spatule perforée
Spatola forata
Pfanneschaufel perforiert



| REF. | L(mm) | € | UE / MOQ |
|------|-------|---|----------------------|
| 9727 | 350 | | 1-12-48-420-840 / 10 |

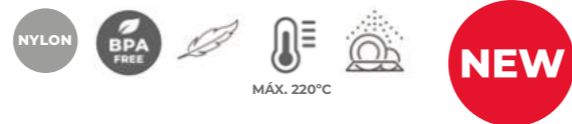

Nylon
Fibra de alta calidad.
Poca porosidad mayor du-
reza.

Nylon
High-quality fibres.
Non-porous, more hard-wea-
ring.

BPA FREE
BPA FREE

Alta resistencia térmica.
Soportan temperatura de
hasta 220°C

Strong heat-resistance.
For use in temperatures
up to 220 °C

No raya.
Suavidad con las superfi-
cies antiadherentes

Non-scratching.
Delicate on
non-stick surfaces

Gancho que permite colgar
para un práctico almacenaje.

*Hanging for convenient stor-
age.*



Muesca
antivuelco
No tipping

| | | L mm | Ø mm | ml | UE / MOQ |
|---|--|------|-------|-------|------------|
| A | 11809 CUCHARA NYLON Spoon, Cuillère, Cucchiaino, Löffel | 49 | | | 1-0-75 / 1 |
| B | 11810 CUCARÓN NYLON 10 Spoon, Louche, Mestolo, Schöpflöffel | 48 | Ø 100 | 200ml | 1-0-50 / 1 |
| | 11811 CUCARÓN NYLON 12 Spoon, Louche Mestolo, Schöpflöffel | 50 | Ø 120 | 350ml | 1-0-75 / 1 |
| | 11812 CUCARÓN NYLON 14 Spoon, Louche, Mestolo, Schöpflöffel | 51 | Ø 140 | 500ml | 1-0-50 / 1 |
| C | 11813 ESPÁTULA NYLON PERFORADA Slotted, Spatula, Spatule Perforé, Spatola Forata, Schanfel perforiert | 51 | | | 1-0-75 / 1 |
| D | 11814 ESPÁTULA NYLON SIN AGUJEROS Spatula W/O, Spatule Sans Trou, Spatola Senza Buchi, Pfannenwender Ohne Löcher | 51 | | | 1-0-75 / 1 |
| E | 11815 ESPUMADERA NYLON 10 Skimmer, Écumaire, Schiumarola, Schaumlöffel | 44 | Ø 100 | | 1-0-75 / 1 |
| | 11816 ESPUMADERA NYLON 12 Skimmer, Écumaire, Schiumarola, Schaumlöffel | 45 | Ø 120 | | 1-0-75 / 1 |
| | 11817 ESPUMADERA NYLON 14 Skimmer, Écumaire, Schiumarola, Schaumlöffel | 47 | Ø 140 | | 1-0-75 / 1 |

| | | L mm | UE / MOQ |
|---|---|------|---------------------|
| A | 8405 CUCHARA SPAGUETTI Spaguetti server, Cuillère spaguetti, Servispaguetti, SpaguettiLöffel | 325 | 1-0-12-120-480 / 12 |
| B | 8407 PINZA COCINA Kitchen pincers, pince, pinza cucina, zange | 310 | 1-0-12-120-480 / 12 |
| C | 8398 CAZO Ladle, louche, mestolo, schöpföffel | 330 | 1-0-24-120-480 / 12 |
| D | 8400 ESPÁTULA PERFORADA Slotted Spatula, Spatule Perforé, Spatola Forata, Pfannenwender Mit Schlitzen | 345 | 1-0-12-120-480 / 12 |
| E | 8399 ESPUMADERA Skimmer Écumaire Schiumarola Schaumlöffel | 335 | 1-0-12-120-480 / 12 |
| F | 8402 PALA LASAÑA Lasagna shovel, palette à lasagne, pala lasagna, lasagneheber | 290 | 1-0-12-120-480 / 12 |
| G | 8404 PALA FREIR Lasagna shovel, palette à lasagne, pala lasagna, lasagneheber | 290 | 1-0-12-120-480 / 12 |
| H | 8403 CUCHARA SERVIR Rice shovel, cuillère de service, cucchiaino riso, servierlöffel | 285 | 1-0-12-120-480 / 12 |
| I | 8406 ESPÁTULA CREPES creppes spatula, palette, spatola creppes, kuchenheber | 335 | 1-0-12-120-480 / 12 |
| J | 8401 PALETA PESCADO Universal shovel, pelle à poisson, pala multiuso, fischheber | 335 | 1-0-12-120-480 / 12 |



Espátula madera
Solid turner
Spatule en bois
Spatola di legno
Holzspachtel



| REF. | L(mm) | € | UE / MOQ |
|-------|-------|---|------------|
| 10717 | 330 | | 1-12-72/12 |



Cuchara madera
Pointed spoon
Cuillère en bois
Cucchiaio di legno
Holzlöffel



| REF. | L(mm) | € | UE / MOQ |
|-------|-------|---|------------|
| 10718 | 330 | | 1-12-72/12 |



Barra de comandas
Order rack
Porte-fiches à billes
Asta portascontrini
Zettelfeiste



| REF. | W(mm) | L(mm) | H(mm) | € | UE / MOQ |
|-------|-------|-------|-------|---|--------------------|
| 9760 | 24 | 615 | 24 | | 1-6-24-168-672 / 6 |
| 11776 | 58 | 1000 | 22 | | 1-0-24 / 1 |



Espolvoreador 3 posiciones
Stainless steel sprinkler 3p
Saupoudreuse acier 3p
Draga acciaio 3p
Strendose 3 pos.



| REF. | H(mm) | € | UE / MOQ |
|------|-------|---|----------------------|
| 8794 | 110 | | 1-1-100-600-1200 / 1 |



Escurre fritos y carnes
Fry colander
Passoire à frites
Cesta per friggere
Frittensieb



| REF. | W(mm) | L(mm) | € | UE / MOQ |
|------|-------|-------|---|-----------------|
| 8381 | 290 | 400 | | 1-0-6-24-24 / 1 |
| 8382 | 390 | 500 | | 1-0-4-12-24 / 1 |
| 8383 | 390 | 600 | | 1-0-3-9-27 / 1 |

Biberón rojo
Red squeeze bottles
Distributeur
à pression rouge
Garrafa rosso
Dosierflasche rot



| REF. | ml | H(mm) | € | UE / MOQ |
|------|-----|-------|---|---------------------|
| 8439 | 240 | 190 | | 1-4-24-240-720 / 24 |
| 8440 | 360 | 220 | | 1-4-24-192-960 / 24 |
| 8441 | 720 | 260 | | 1-4-24-144-576 / 24 |

Biberón amarillo
Yellow squeeze bottles
Distributeur
à pression jaune
Garrafa giallo
Dosierflasche Gelb



| REF. | ml | H(mm) | € | UE / MOQ |
|------|-----|-------|---|---------------------|
| 8442 | 240 | 190 | | 1-4-24-240-720 / 24 |
| 8443 | 360 | 220 | | 1-4-24-192-960 / 24 |
| 8444 | 720 | 260 | | 1-4-24-144-720 / 24 |



Triple boquilla:
ideal para decoraciones.
Triple nozzle:
great for decorations.

Biberón triple
Triple squeeze bottle
Triple distributeur
Garrafa com boquilha triplo
Dosierflasche mit Dreifachdüse

| REF. | ml | H(mm) | € | UE / MOQ |
|------|-----|-------|---|---------------------|
| 8449 | 360 | 180 | | 1-4-24-192-960 / 24 |
| 8450 | 720 | 245 | | 1-4-24-144-576 / 24 |



Todos los biberones
tienen marcas de medición
en milímetros.
All bottles
have measurement marks
in millimeters.



Biberón transparente
Clear squeeze bottles
Distributeur à pression transparent
Garrafa trasparente
Dosierflasche transparent

| REF. | ml | H(mm) | € | UE / MOQ |
|------|-------|-------|---|----------------------|
| 8445 | 240 | 190 | | 1-4-24-240-1200 / 24 |
| 8446 | 360 | 220 | | 1-4-24-216-1080 / 24 |
| 8447 | 720 | 260 | | 1-4-24-144-576 / 24 |
| 8448 | 1.000 | 310 | | 1-4-24-96-384 / 24 |



INOX
STAINLESS
STEEL
201

Rustidera
Lasagna pan
Plat à rôtir
Rostiera
Lasagneform



| REF. | W(mm) | L(mm) | H(mm) | € | UE / MOQ |
|------|-------|-------|-------|---|--------------------|
| 1422 | 250 | 180 | 40 | | 1-0-24-144-288 / 4 |
| 1421 | 300 | 220 | 50 | | 1-0-12-72-144 / 4 |
| 1420 | 350 | 260 | 50 | | 1-0-12-72-144 / 4 |
| 1419 | 400 | 300 | 60 | | 1-0-12-72-144 / 4 |
| 5282 | 450 | 320 | 65 | | 1-0-4-16-48 / 4 |
| 5283 | 500 | 360 | 70 | | 1-0-4-16-32 / 4 |
| 5284 | 600 | 400 | 75 | | 1-0-4-16-16 / 4 |

INOX
STAINLESS
STEEL
201

Pinza para rustidera
Lasagna pan tong
Pince plat à rôtir
Molla forno
Ofenzange



| REF. | L(mm) | € | UE / MOQ |
|------|-------|---|-----------------------|
| 5656 | 185 | | 1-10-100-600-1800 / 6 |

INOX
STAINLESS
STEEL
304

Harinero
Flour bin
Tamis à farine inox
Farinheiro
Mehlsieb

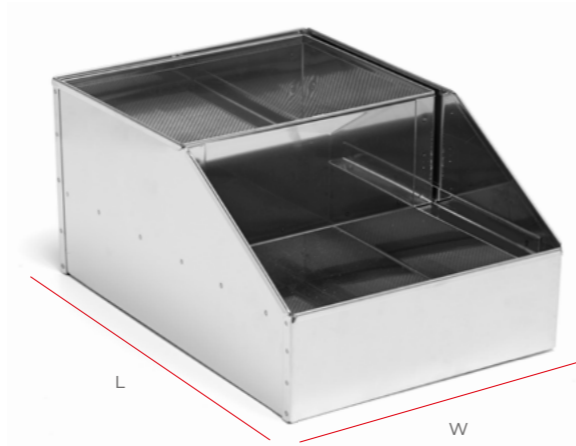

| REF. | W(mm) | L(mm) | H(mm) | € | UE / MOQ |
|------|-------|-------|-------|---|----------------|
| 8384 | 265 | 370 | 180 | | 1-0-1-8-24 / 1 |
| 8385 | 265 | 500 | 180 | | 1-0-1-6-18 / 1 |
| 8386 | 330 | 500 | 180 | | 1-0-1-4-12 / 1 |

NEW

INOX
STAINLESS
STEEL
201

Colador Chino Piston
Piston Funnel
Passoire Chinois Piston
Colino Chinese A Pistone
Passiersieb



| REF. | L (mm) | W(mm) | H(mm) | € | UE / MOQ |
|-------|--------|-------|-------|---|---------------|
| 11777 | 280 | 200 | 240 | | 1-0-8-0-0 / 1 |

INOX
STAINLESS
STEEL
201

Colador chino con clip
Conical soup strainer with clip
Passoire chinois
Cornetto cinese
Spitzsieb



| REF. | Ø(mm) | € | UE / MOQ |
|------|-------|---|---------------------|
| 9764 | 160 | | 1-0-60-240-480 / 10 |
| 9765 | 180 | | 1-0-60-240-480 / 10 |
| 9766 | 200 | | 1-0-60-240-480 / 10 |
| 9767 | 220 | | 1-0-60-240-480 / 10 |
| 9768 | 240 | | 1-0-30-120-240 / 10 |
| 9769 | 260 | | 1-0-30-120-240 / 10 |

NEW

INOX
STAINLESS
STEEL
201

Colador Malla
Mesh Sieve
Passoire Maille
Colino A Maglia
Küchensieb



| REF. | Ø(mm) | H(mm) | € | UE / MOQ |
|-------|-------|-------|---|---------------|
| 11950 | 200 | 220 | | 1-0-6-0-0 / 1 |
| 11949 | 250 | 270 | | 1-0-6-0-0 / 1 |

INOX
STAINLESS
STEEL
201

Colador fino
Oil strainer
Passoire à huile
Colino per l'olio
Ölsieb

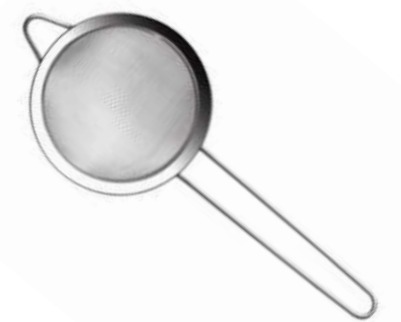

| REF. | Ø(mm) | € | UE / MOQ |
|------|-------|---|---------------------|
| 2884 | 80 | | 1-0-24-960-1920 / 6 |
| 2885 | 100 | | 1-0-24-960-1920 / 6 |
| 2886 | 120 | | 1-0-24-960-1920 / 6 |
| 2887 | 140 | | 1-0-24-960-1920 / 6 |
| 2888 | 160 | | 1-0-24-960-1920 / 6 |
| 2889 | 180 | | 1-0-24-960-1920 / 6 |
| 2890 | 200 | | 1-0-24-960-1920 / 6 |

INOX
STAINLESS
STEEL
304

Cedazo Velo

Sieve velo
Tamis velo
Setaccio velo
Mehlsieb

| REF. | Ø(mm) | € | UE / MOQ |
|-------|-------|---|-------------------|
| 10650 | 250 | | 1-6-12-96-192 / 1 |
| 10651 | 300 | | 1-6-12-36-108 / 1 |
| 10652 | 350 | | 1-4-8-48-96 / 1 |



MEDIDA MALLA / MESH SIZE:
1,5 x 1 mm

INOX
STAINLESS
STEEL
304

Cedazo Harina

Flour sieve
Tamis farine
Setacciofarina
Mehlsieb

| REF. | Ø(mm) | € | UE / MOQ |
|-------|-------|---|-------------------|
| 10653 | 250 | | 1-6-12-96-192 / 1 |
| 10654 | 300 | | 1-6-12-72-144 / 1 |
| 10655 | 350 | | 1-4-8-48-96 / 1 |

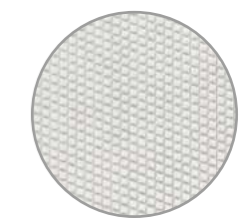

MEDIDA MALLA / MESH SIZE:
2,5 x 1,4 mm

INOX
STAINLESS
STEEL
304

Cedazo Pan

Bread Sieve
Tamis pain
Setaccio pane
Brotsieb

| REF. | Ø(mm) | € | UE / MOQ |
|-------|-------|---|-------------------|
| 10656 | 300 | | 1-6-12-36-108 / 1 |
| 10657 | 350 | | 1-4-8-48-96 / 1 |

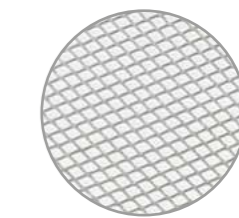

MEDIDA MALLA / MESH SIZE:
4 x 3 mm

INOX
STAINLESS
STEEL
304

Cedazo Pescado

Fish sieve
Tamis poisson
Setaccio peixe
Fischsieb

| REF. | Ø(mm) | € | UE / MOQ |
|-------|-------|---|-------------------|
| 10658 | 300 | | 1-6-12-36-108 / 1 |
| 10659 | 350 | | 1-4-8-48-96 / 1 |



MEDIDA MALLA / MESH SIZE:
11 x 9 mm

INOX
STAINLESS
STEEL
430

Barillas de acero inoxidable de alta resistencia.

Tough stainless steel bars.

NYLON

Mango de nylon de forma ergonómica. Con relieves para mejorar el agarre.

Ergonomic nylon handle. Raised pattern for better grip.

Fácil almacenaje.

Easy to store.



Batidor 8 varillas Nylon

Whisk 8 wires
Fouet 8 fils
Frusta 8 fili
Rührbesen 8 Drähte

| REF. | L (mm) | VARILLAS (mm) | € | UE / MOQ |
|------|--------|---------------|---|-----------------------|
| 8480 | 250 | 12 | | 1-12-48-380-1920 / 12 |
| 8481 | 300 | 170 | | 1-12-48-288-864 / 12 |
| 8482 | 350 | 220 | | 1-12-48-284-864 / 12 |
| 8483 | 400 | 250 | | 1-6-24-120-600 / 6 |



INOX
STAINLESS
STEEL
201

Batidor 8 varillas

Whisk 8 wires
Fouet 8 fils
Frusta 8 fili
Rührbesen 8 Drähte

| REF. | L (mm) | VARILLAS (mm) | € | UE / MOQ |
|------|--------|---------------|---|---------------------|
| 9740 | 250 | 12 | | 1-0-30-360-720 / 10 |
| 9741 | 300 | 170 | | 1-0-30-270-540 / 10 |
| 9742 | 350 | 220 | | 1-0-30-240-480 / 10 |
| 9743 | 400 | 250 | | 1-0-30-180-360 / 10 |
| 9744 | 450 | 290 | | 1-0-30-120-240 / 10 |
| 9745 | 500 | 370 | | 1-0-30-120-240 / 10 |



Cuchara silicona

Silicon spoon
Cuillère silicone
Cucchiaio silicone
Silikonlöffel

SILICONE
MÁX. 230°C

| REF. | L (mm) | € | UE / MOQ |
|------|--------|---|-----------------------|
| 8484 | 250 | | 1-12-7-108-6048 / 12 |
| 8485 | 350 | | 1-12-72-648-2592 / 12 |
| 8486 | 400 | | 1-12-72-576-2304 / 12 |



Espátula silicona

Silicon spatula
Spatule silicone
Spatola silicone
Silikonspachtel

SILICONE
MÁX. 230°C

| REF. | L (mm) | € | UE / MOQ |
|------|--------|---|------------------------|
| 8487 | 250 | | 1-12-72-1296-7776 / 12 |
| 8488 | 350 | | 1-12-72-792-3168 / 12 |
| 8489 | 400 | | 1-12-72-720-2880 / 12 |

PP
POLYPRO-
PYLENE

Jarra medidora

Measuring PP jug
Pichet gradué PP
Caraffa graduata
Messbecher



| REF. | ml | H(mm) | € | UE / MOQ |
|------|-------|-------|---|-----------------------|
| 8451 | 500 | 133 | | 1-12-72-360-1080 / 12 |
| 8452 | 1.000 | 160 | | 1-6-60-180-540 / 6 |
| 8453 | 2.000 | 215 | | 1-6-60-180-180 / 6 |

PASTELERÍA
PASTRY

PP
POLYPRO-
PYLENE

Espátula pastelera

Small baker spatula
Palette
Spatola cuoco
Kuchenspachtel

| REF. | SIZE | HOJA (mm) | € | UE / MOQ |
|------|------|-----------|---|----------------------|
| 8932 | s | 135 | | 1-12-48-576-152 / 12 |
| 8933 | M | 225 | | 1-12-48-480-960 / 12 |
| 8934 | L | 300 | | 1-12-48-432-864 / 12 |

INOX
STAINLESS
STEEL
201

Bol semiesférico

Mixing bowl
Bassine hémisphérique
Bastardella semisferica
Schnees Schlagkessel



| REF. | Ø (mm) | € | UE / MOQ |
|------|--------|---|------------------------|
| 9748 | 160 | | 1-0-100-1000-3000 / 10 |
| 9749 | 220 | | 1-0-50-600-1200 / 10 |
| 9750 | 240 | | 1-0-50-600-1800 / 10 |
| 9751 | 300 | | 1-0-50-300-600 / 10 |
| 9752 | 340 | | 1-0-25-150-450 / 5 |
| 9753 | 360 | | 1-0-25-150-450 / 5 |
| 9754 | 400 | | 1-0-25-150-300 / 5 |

INOX
STAINLESS
STEEL
201

Flanera profesional

Pudding mould
Moule à flan
Crème caramel
Becherförmchen



| REF. | Ø (mm) | H (mm) | € | UE / MOQ |
|------|--------|--------|---|------------------------|
| 9632 | 75 | 50 | | 1-12-120-960-3840 / 12 |
| 9633 | 85 | 55 | | 1-12-120-960-3840 / 12 |



Cocción / Sartenes y baterías profesionales
Cooking / Professionals fry pans and cookware

COLECCIÓN SARTENES / FRY PANS COLLECTION

/ ETNA / TEIDE / VULCANO / CROSCAT / AUVERNIA / USSON / VESUVIO / FUJI



| | | | | | | | | | |
|--|--|-----------------------|-----------------------|-----------------------|-----------------------|-----------------------|-----------------------|------|------|
| | SARTÉN FRY PAN | ALUMINIO ALUMINIUM | ALUMINIO ALUMINIUM | ALUMINIO ALUMINIUM | ALUMINIO ALUMINIUM | ALUMINIO ALUMINIUM | ALUMINIO ALUMINIUM | INOX | INOX |
| | MANGO HANDLE | INOX | INOX | INOX | INOX | HIERRO IRON | HIERRO IRON | INOX | INOX |
| | ANTIADHERENTE NON-STICK | | | | | | | | |
| | VITRO | ● | ● | ● | ● | ● | ● | ● | ● |
| | ELÉCTRICO ELECTRIC | ● | ● | ● | ● | ● | ● | ● | ● |
| | GAS | ● | ● | ● | ● | ● | ● | ● | ● |
| | INDUCCIÓN INDUCTION | | ● | | ● | | ● | ● | ● |
| | HORNO OVEN | ● | ● | ● | ● | | | | |
| | APTO CONTACTO ALIMENTARIO FOODCONTACT SAFE | | | | | | | | |

COLECCIÓN BATERIA / COOKWARE COLLECTION

CROSCAT



| | | | | | | | | |
|----------------|-----------------|----------------------------|-------|-----------------------|-----|------------------------|---------------|--|
| | | | | | | | | |
| CUERPO BODY | ASAS HANDLES | ANTIADHERENTE NON-STICK | VITRO | ELÉCTRICO ELECTRIC | GAS | INDUCCIÓN INDUCTION | HORNO OVEN | APTO CONTACTO ALIMENTARIO FOODCONTACT SAFE |



Antiadherente / Non-stick

Cocción / Sartenes profesionales
Cooking / Professionals fry pans



Doble capa antiadherente de alta calidad.

High quality double non-stick coating.

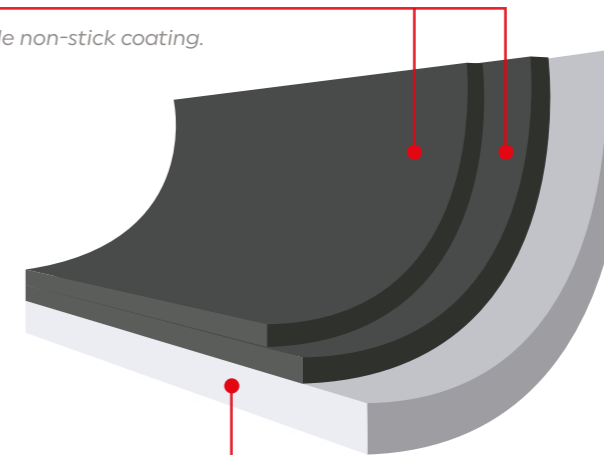

Aluminio de 3mm de espesor

3mm thick aluminium



Recomendamos el uso de utensilios de nylon para alargar la vida del recubrimiento antiadherente en perfectas condiciones.

We recommend the use of nylon utensils to extend the life of the non-stick coating in perfect condition.

Revestimiento antiadherente de fluororesina de grado universal de PFLUON con sistemas de revestimiento de dos capas. Esta serie de revestimientos es densa, antiadherente y fácil de limpiar.

PFLUON trabaja con el instituto de certificación de renombre mundial SGS para garantizar que los productos y servicios cumplen las normas mundiales y la normativa local. Podemos demostrarle que el antiadherente COOKMARK cumple las normas y especificaciones nacionales e internacionales.

PFLUON universal grade fluororesin non-stick coating with two-layer coating systems. This coating series is dense, non-stick and easy to clean.

PFLUON works with the world-renowned certification institute SGS to ensure that products and services meet global standards and local regulations. We can prove that COOKMARK non-stick coating meets national and international standards and specifications.



Sartenes diseñadas para resistir los servicios más exigentes.

Mango hermético.

Sealed handle.

Mango fabricado en acero inoxidable de forma tubular para facilitar la sujeción de la sartén.

Tubular stainless steel handle for easy handling.

Remachado al cuerpo de la sartén para proporcionar una sujeción superior y una máxima seguridad en el momento de su uso.

Riveted to the pan for strength and safety in use.

Eficiencia de la distribución calórica: Su cuerpo de aluminio de alta calidad capta y distribuye de la mejor manera el calor por toda la superficie.

Efficient conduction of heat: The high-quality aluminium body captures and conducts heat across the whole surface.



Recubrimiento totalmente libre de PFOA.

Coating totally PFOA-free.



4mm de grosor en tamaños grandes.
4mm thickness in large sizes.



ETNA

Sartén aluminio mango inox

Aluminium fry pan with inox handle
Poêle aluminium manche en inox
Padella in alluminio manico in inox
Bratpfanne aluminium mit inoxgriff

| REF. | Ø(mm) | e(mm) | € | UE / MOQ |
|------|-------|-------|---|-------------------|
| 8342 | 180 | 2,5 | | 1-0-6-54-324 / 12 |
| 8343 | 200 | 3,5 | | 1-0-6-36-324 / 12 |
| 8344 | 220 | 3,5 | | 1-0-6-30-240 / 12 |
| 8345 | 240 | 3,5 | | 1-0-6-24-216 / 6 |
| 8346 | 260 | 4 | | 1-0-6-24-216 / 6 |
| 8347 | 280 | 4 | | 1-0-6-24-192 / 6 |
| 8348 | 320 | 4 | | 1-0-6-12-96 / 6 |
| 8349 | 360 | 4 | | 1-0-6-12-84 / 6 |
| 8350 | 400 | 4 | | 1-0-6-12-96 / 6 |



TEIDE

Sartén aluminio mango inox / Inducción

Aluminium induction fry pan with inox handle
Poêle induction aluminium manche en inox
Padella induzione in alluminio manico in inox
Bratpfanne aluminium mit inoxgriff induktion



Fondo de inducción. Difusión rápida y uniforme del calor.
Induction base. Rapid, uniform distribution of heat.

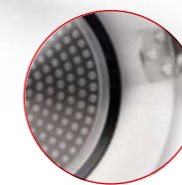

| REF. | Ø(mm) | e(mm) | € | UE / MOQ |
|-------|-------|-------|---|------------------|
| 8954 | 200 | 3 | | 1-0-6-36-324 / 6 |
| 8955 | 240 | 3 | | 1-0-6-24-216 / 6 |
| 8956 | 280 | 3 | | 1-0-6-24-192 / 6 |
| 8957 | 320 | 3 | | 1-0-6-12-96 / 6 |
| 11778 | 360 | 3 | | 1-0-6-12-84 / 6 |
| 11996 | 400 | 3 | | 1-0-6-12-96 / 6 |



VULCANO

Sartén aluminio antiadherente alta mango inox

Deep frypan, non stick coating
Poêle avec revêtement anti-adhésif
Padella inox antiaderente
Bratpfanne Aluminium mit inoxgriff



SARTÉN HONDA DEEP PAN

| REF. | Ø(mm) | e(mm) | H(mm) | € | UE / MOQ |
|------|-------|-------|-------|---|------------------|
| 9971 | 200 | 3 | 55 | | 1-0-6-36-288 / 6 |
| 9972 | 240 | 3 | 60 | | 1-0-6-24-192 / 6 |
| 9973 | 280 | 3 | 65 | | 1-0-6-24-144 / 6 |
| 9974 | 320 | 3 | 75 | | 1-0-6-0-0 / 6 |
| 9975 | 360 | 3 | 80 | | 1-0-6-0-0 / 6 |
| 9976 | 400 | 3 | 85 | | 1-0-6-0-0 / 6 |

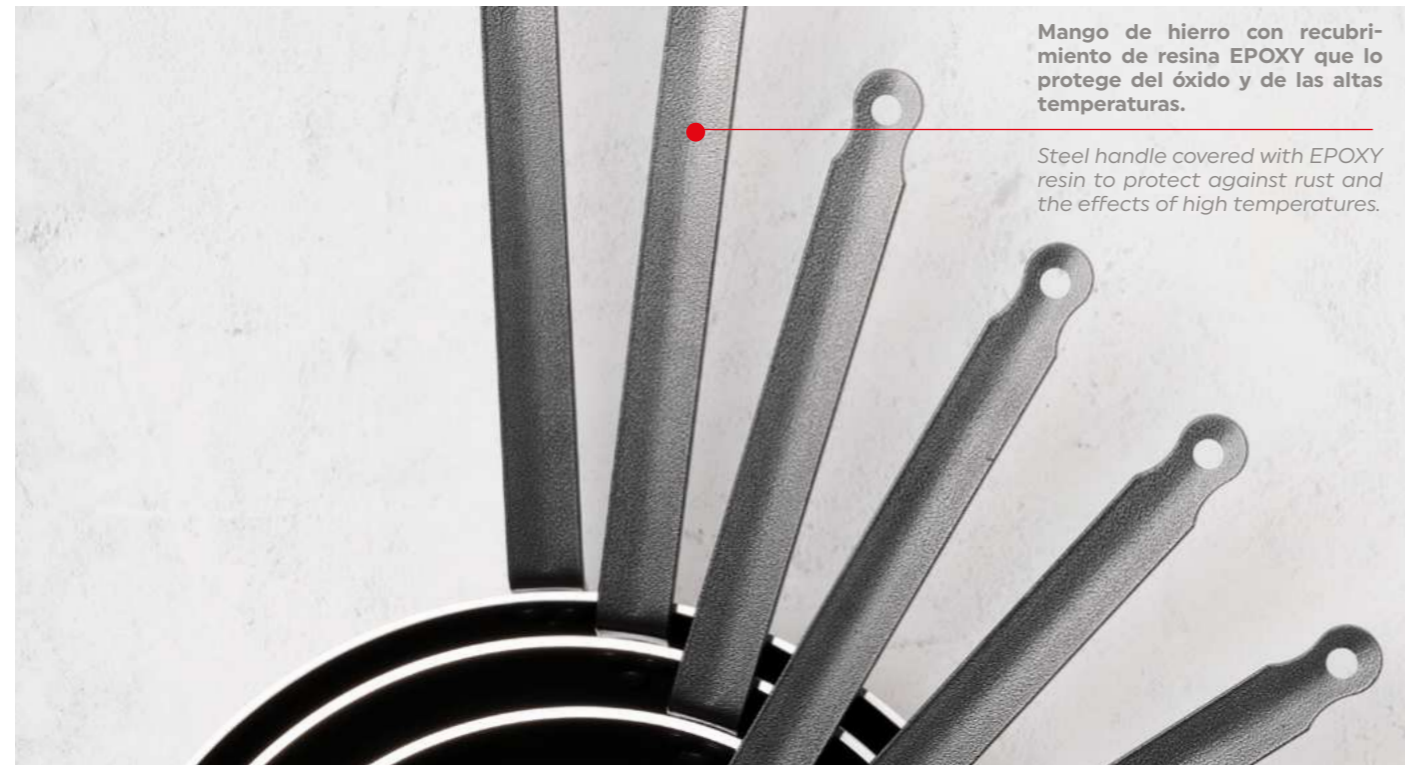

Mango de hierro con recubrimiento de resina EPOXY que lo protege del óxido y de las altas temperaturas.

Steel handle covered with EPOXY resin to protect against rust and the effects of high temperatures.



AUVERNIA

Sartén aluminio mango hierro
Aluminium fry pan with iron handle
Poêle aluminium manche en fer
Padella in alluminio manico in ferro
Aluminium-Bratfanne mit Eisengriff

| REF. | Ø(mm) | e(mm) | € | UE / MOQ |
|------|-------|-------|---|-------------------|
| 8351 | 180 | 2,5 | | 1-0-6-54-324 / 12 |
| 8352 | 200 | 3,5 | | 1-0-6-36-324 / 12 |
| 8353 | 220 | 3,5 | | 1-0-6-30-240 / 12 |
| 8354 | 240 | 3,5 | | 1-0-6-24-216 / 6 |
| 8355 | 260 | 4 | | 1-0-6-24-216 / 6 |
| 8356 | 280 | 4 | | 1-0-6-24-192 / 6 |
| 8357 | 320 | 4 | | 1-0-6-12-96 / 6 |
| 8358 | 360 | 4 | | 1-0-6-12-84 / 6 |
| 8359 | 400 | 4 | | 1-0-6-12-96 / 6 |

4mm de grosor en tamaños grandes.
4mm thickness in large sizes.



USSON

Sartén aluminio mango hierro / Inducción
Aluminium induction fry pan with inox handle
Poêle induction aluminium manche en inox
Padella induzione in alluminio manico in inox
Induktion aluminium-Bratfanne mit inoxgriff induktion

| REF. | Ø(mm) | e(mm) | € | UE / MOQ |
|------|-------|-------|---|------------------|
| 8958 | 200 | 3 | | 1-0-6-36-324 / 6 |
| 8959 | 240 | 3 | | 1-0-6-24-216 / 6 |
| 8960 | 280 | 3 | | 1-0-6-24-192 / 6 |
| 8961 | 320 | 3 | | 1-0-6-12-96 / 6 |



Fondo de inducción. Difusión rápida y uniforme del calor.
Induction base. Rapid, uniform distribution of heat.

CAPAS EXTERIORES
ACERO INOXIDABLE SUPERIOR
Mezcla cromo, titanio y cobre.
EXTERIOR LAYERS
SUPERIOR STAINLESS STEEL
Mixing chrome, titanium and copper.



CAPA INTERIOR
ALUMINIO
INTERIOR LAYER
ALUMINIUM

BASE SANDWICH SYSTEM



- Alta resistencia a la corrosión y los ácidos alimentarios.
Highly resistant to rust and food acids.
- Menos porosidad, más higiénico.
Less porous, more hygienic surface.
- Óptima difusión del calor por toda la superficie.
Optimum heat distribution across the whole base.
- Muy resistente a las altas temperaturas y al desgaste.
Hard-wearing and tolerant of high temperatures.
- Apta para inducción.
Suitable for induction.



FUJI

Sartén inox mango inox
Frypan inox
Poêle à frire inox
Padella inox
Inox-Bratfanne

| REF. | Ø(mm) | e(mm) | € | UE / MOQ |
|--------|-------|-------|---|------------------|
| 8515 | 200 | 0,7 | | 1-0-6-36-288 / 1 |
| 8516 | 240 | 0,7 | | 1-0-6-24-192 / 1 |
| 8517 | 280 | 0,7 | | 1-0-6-24-192 / 1 |
| * 8518 | 320 | 1 | | 1-0-4-8-64 / 1 |
| * 8519 | 360 | 1 | | 1-0-4-4-24 / 1 |
| * 8520 | 400 | 1 | | 1-0-4-4-28 / 1 |



Base sistema SANDWICH
SADWICH system base



VESUVIO

Sartén inox antiadherente mango inox
Frypan, non stick coating
Poêle avec revêtement anti-adhésif
Padella inox antiaderente
Bratfanne mit Antihftbeschichtung

| REF. | Ø(mm) | e(mm) | € | UE / MOQ |
|--------|-------|-------|---|------------------|
| 8509 | 200 | 0,7 | | 1-0-6-36-288 / 1 |
| 8510 | 240 | 0,7 | | 1-0-6-24-192 / 1 |
| 8511 | 280 | 0,7 | | 1-0-6-24-144 / 1 |
| * 8512 | 320 | 1 | | 1-0-4-8-64 / 1 |
| * 8513 | 360 | 1 | | 1-0-4-4-28 / 1 |
| * 8514 | 400 | 1 | | 1-0-4-4-28 / 1 |



Asa adicional en diámetros grandes.
Additional handle on large diameters.

Nuestra colección CROSCAT está diseñada para satisfacer las exigencias de la cocina profesional, con una batería de servicio que incluye todas las piezas esenciales para la preparación de recetas perfectas.

Our CROSCAT collection is designed to meet the demands of the professional kitchen, with a service set that includes all the essential pieces for the preparation of perfect recipes.



**Descubre la
gama de baterías y sartenes.**



SARTÉN
HONDA
DEEP
PAN

Asa adicional en diámetros grandes.
Additional handle on large diameters.

Sartén aluminio antiadherente alta mango inox
Deep frypan, non stick coating
Poêle avec revêtement anti-adhésif
Padella inox antiaderente
Bratpfanne mit antihaftbes

| REF. | Ø(mm) | e(mm) | H(mm) | € | UE / MOQ |
|-----------|-------|-------|-------|---|------------------|
| 10897 | 240 | 3 | 70 | | 1-0-6-24-144 / 6 |
| 10898 | 280 | 3 | 75 | | 1-0-6-24-144 / 6 |
| 10899 | 320 | 3 | 80 | | 1-0-6-18-108 / 6 |
| NEW 11599 | 360 | 3 | 80 | | 1-0-4-0-0 / 4 * |
| NEW 11601 | 400 | 3 | 90 | | 1-0-4-0-0 / 4 * |

Cazuela aluminio
Aluminium casserole
Casserole aluminium
Casseruola in alluminio
Aluminiumkasserolle

| REF. | Ø(mm) | e(mm) | H(mm) | € | UE / MOQ |
|-------|-------|-------|-------|---|------------------|
| 11611 | 280 | 3 | 70 | | 1-0-6-24-144 / 6 |
| 11612 | 320 | 3 | 80 | | 1-0-6-18-108 / 6 |
| 11613 | 360 | 3 | 80 | | 1-0-4-0-0 / 4 |
| 11615 | 400 | 3 | 90 | | 1-0-4-0-0 / 4 |



NEW

Cazo Recto
Straight Ladle
Casserole Droite
Mestolo Dritto
Stieltopf

| REF. | Ø(mm) | e(mm) | H(mm) | LITROS | € | UE / MOQ |
|-------|-------|-------|-------|--------|---|---------------|
| 11789 | 140 | 3 | 68 | 0,95 | | 1-0-6-0-0 / 6 |
| 11790 | 160 | 3 | 76 | 1,4 | | 1-0-6-0-0 / 6 |
| 11791 | 180 | 3 | 85 | 2 | | 1-0-6-0-0 / 6 |
| 11792 | 200 | 3 | 98 | 2,88 | | 1-0-6-0-0 / 6 |



NEW

Olla
Saucepan
Casserole
Pentola
Topf

| REF. | Ø(mm) | e(mm) | H(mm) | LITROS | € | UE / MOQ |
|-------|-------|-------|-------|--------|---|---------------|
| 11780 | 200 | 3 | 140 | 4,18 | | 1-0-4-0-0 / 4 |
| 11781 | 240 | 3 | 150 | 6,46 | | 1-0-4-0-0 / 4 |
| 11782 | 280 | 3 | 170 | 9,98 | | 1-0-4-0-0 / 4 |
| 11951 | 300 | 3 | 180 | 12,22 | | 1-0-4-0-0 / 4 |
| 11952 | 320 | 3 | 185 | 14,32 | | 1-0-4-0-0 / 4 |



NEW

Cacerola
Casserole
Fait-Tout
Casseruola
Stielkasserolle

| REF. | Ø(mm) | e(mm) | H(mm) | LITROS | € | UE / MOQ |
|-------|-------|-------|-------|--------|---|---------------|
| 11787 | 240 | 3 | 100 | 4,25 | | 1-0-4-0-0 / 4 |
| 11788 | 280 | 3 | 110 | 6,27 | | 1-0-4-0-0 / 4 |
| 11953 | 300 | 3 | 120 | 8 | | 1-0-4-0-0 / 4 |



NEW

Tapa Borosilicato
Borosilicate Lid
Couvercle Borosilicate
Coperchio In Vetro Borosilicato
Deckel Borosilikat Glasdeckel

| REF. | Ø(mm) | € | UE / MOQ |
|-------|-------|---|-----------------|
| 11794 | 200 | | 1-0-12-0-0 / 12 |
| 11795 | 240 | | 1-0-12-0-0 / 12 |
| 11796 | 280 | | 1-0-12-0-0 / 12 |
| 11954 | 300 | | 1-0-12-0-0 / 12 |
| 11955 | 320 | | 1-0-12-0-0 / 12 |



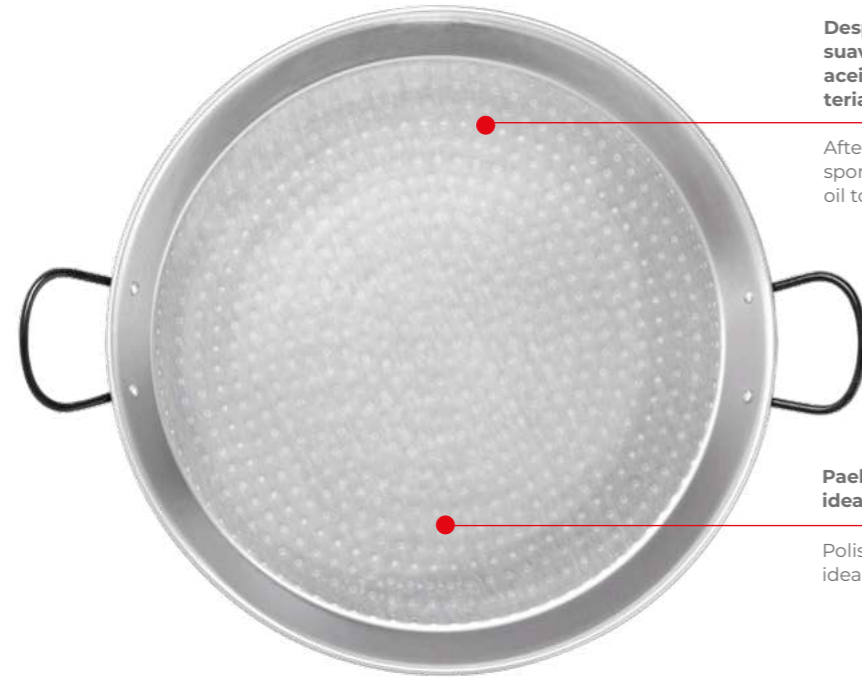

Después de usar lavar con esponja suave, secar y aplicar una capa de aceite de oliva para conservar el material.

After use, wash with a non-abrasive sponge, dry and apply a coat of olive oil to protect the material.

Paellera de acero pulido ideal para cocción de llama.

Polished steel paella pan, ideal for use over flame.



Paellera de acero con recubrimiento de esmalte que le proporciona una mayor resistencia al óxido.

Rust-resistant enamelled steel paella pan.

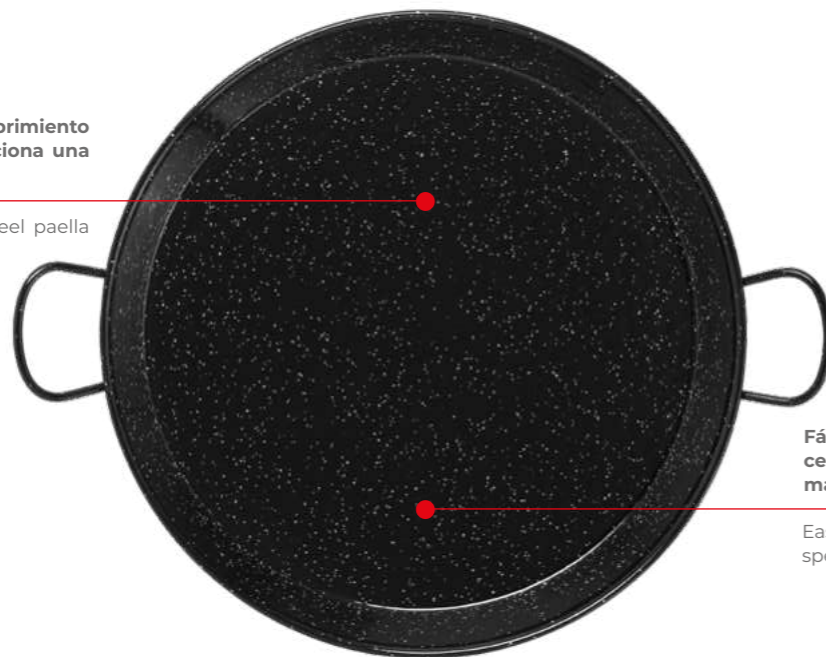

Fácil de limpiar y de almacenar, no precisan de un mantenimiento específico.

Easy to clean and store, no special care is required.





EL SALER

Paellera acero pulido
Polished steel spanish paella pan
Plat à paella tole acier
Padella valenciana lucida
Paellapfanne aus poliertem Stahl

| REF. | Ø(cm) | Raciones | € | UE / MOQ |
|-------|-------|----------|---|-----------------|
| 8964 | 30 | 4 | | 1-0-6-24-144 /1 |
| 8965 | 34 | 6 | | 1-0-6-24-120 /1 |
| 8966 | 38 | 8 | | 1-0-6-12-60 /1 |
| 8967 | 42 | 10 | | 1-0-6-12-60 /1 |
| 8968 | 46 | 12 | | 1-0-4-8-48 /1 |
| 8969 | 50 | 13 | | 1-0-4-8-48 /1 |
| 8970 | 60 | 20 | | 1-0-4-4-24 /1 |
| 10937 | 65 | 25 | | 1-0-0-0-0 /1 |
| 10938 | 70 | 30 | | 1-0-0-0-0 /1 |
| 10939 | 80 | 40 | | 1-0-0-0-0 /1 |
| 10940 | 90 | 50 | | 1-0-0-0-0 /1 |

Paellera grande acero pulido
Polished steel spanish paella pan
Plat à paella tole acier
Padella valenciana lucida
Paellapfanne aus poliertem Stahl



| REF. | Ø(cm) | Raciones | € | UE / MOQ |
|-------|-------|----------|---|--------------|
| 10941 | 100 | 85 | | 1-0-0-0-0 /1 |
| 10942 | 115 | 120 | | 1-0-0-0-0 /1 |
| 10943 | 130 | 200 | | 1-0-0-0-0 /1 |

COMPATIBLE CON
COMPATIBLE WITH:
REF.: 10944 (P.314)



RIBA ROJA

Paellera acero esmaltado
Enamelled steel paella pan
Plat à paella acier émaillé
Padella valenciana smaltata
Paellapfanne aus emailliertem Stahl

| REF. | Ø(cm) | Raciones | € | UE / MOQ |
|------|-------|----------|---|-----------------|
| 8971 | 30 | 4 | | 1-0-6-24-144 /1 |
| 8972 | 34 | 6 | | 1-0-6-24-120 /1 |
| 8973 | 38 | 8 | | 1-0-6-12-60 /1 |
| 8974 | 42 | 10 | | 1-0-6-12-60 /1 |
| 8975 | 46 | 12 | | 1-0-4-8-48 /1 |
| 8976 | 50 | 13 | | 1-0-4-8-48 /1 |
| 8977 | 60 | 20 | | 1-0-4-4-24 /1 |



ALBUFERA

Sartén honda acero esmaltado
Deep enamelled fry pan with handles.
Poele haute avec anses.
Padella smaltata con manici.
Tiefe Paellapfanne aus emailliertem Stahl mit Griffen.

| REF. | Ø(cm) | € | UE / MOQ |
|------|-------|---|-----------------|
| 8978 | 28 | | 1-0-6-24-120 /1 |
| 8979 | 32 | | 1-0-6-24-120 /1 |
| 8980 | 36 | | 1-0-4-8-40 /1 |
| 8981 | 40 | | 1-0-4-8-40 /1 |
| 8982 | 45 | | 1-0-3-6-30 /1 |
| 8983 | 50 | | 1-0-3-6-30 /1 |

* También para raciones individuales.
Also for individual portions.
COLECCIÓN PELTRE (p.405)



Tripode regulable para quemador
Base for burner
Pied pour bruleur
Treppiede padella
Dreifusständer für Gasbrenner

| REF. | W(cm) | H(cm) | € | UE / MOQ |
|------|-------|-------|---|--------------|
| 8984 | 300 | 300 | | 1-0-1-3-9 /1 |



Paravientos 3 piezas
Windshield
Pare-bris 3 pieces
Paravento 3 pezzi
Windschutzblech

| REF. | W(cm) | H(cm) | € | UE / MOQ |
|------|-------|-------|---|---------------|
| 8505 | 670 | 160 | | 1-0-1-6-96 /1 |



Quemador paellero a gas
Enamelled gas burner
Brulleur émaillé
Bruciatore smaltato padella
Emaillierter Gasbrenner



Quemador de cocción para uso doméstico y/o profesional. Fabricado en acero y recubierto de una capa de esmalte. Diseñado para ser utilizado en el exterior.

Burner for domestic or professional use. Made of enamelled steel. Designed for outdoor use.

| REF. | Ø(cm) | PARA PAELLERAS: | € | UE / MOQ |
|------|-------|-----------------|---|---------------|
| 8985 | 30 | 36 - 42CM | | 1-0-1-4-24 /1 |
| 8986 | 40 | 26 - 60CM | | 1-0-1-3-12 /1 |
| 8987 | 50 | 36 - 70CM | | 1-0-1-2-10 /1 |



Este producto está certificado según la normativa de gas vigente. Conexión roscada especial para Gas Natural.

También disponible bajo demanda para otras conexiones europeas.

This product has been certified under the law relating to gas appliances. Threaded Natural Gas connector.

Available on request to fit other European connectors.



Quemador paellero a gas grande
Enamelled gas burner
Brulleur émaillé
Bruciatore smaltato padella
Emaillierter Gasbrenner



| REF. | Ø(cm) | € | UE / MOQ |
|-------|-------|---|--------------|
| 10944 | 90 | | 1-0-0-0-0 /1 |

* Trípode incluido.
Funciona con 2 botellas de butano o propano.

Tripod included.
Works with 2 butane or propane bottles.

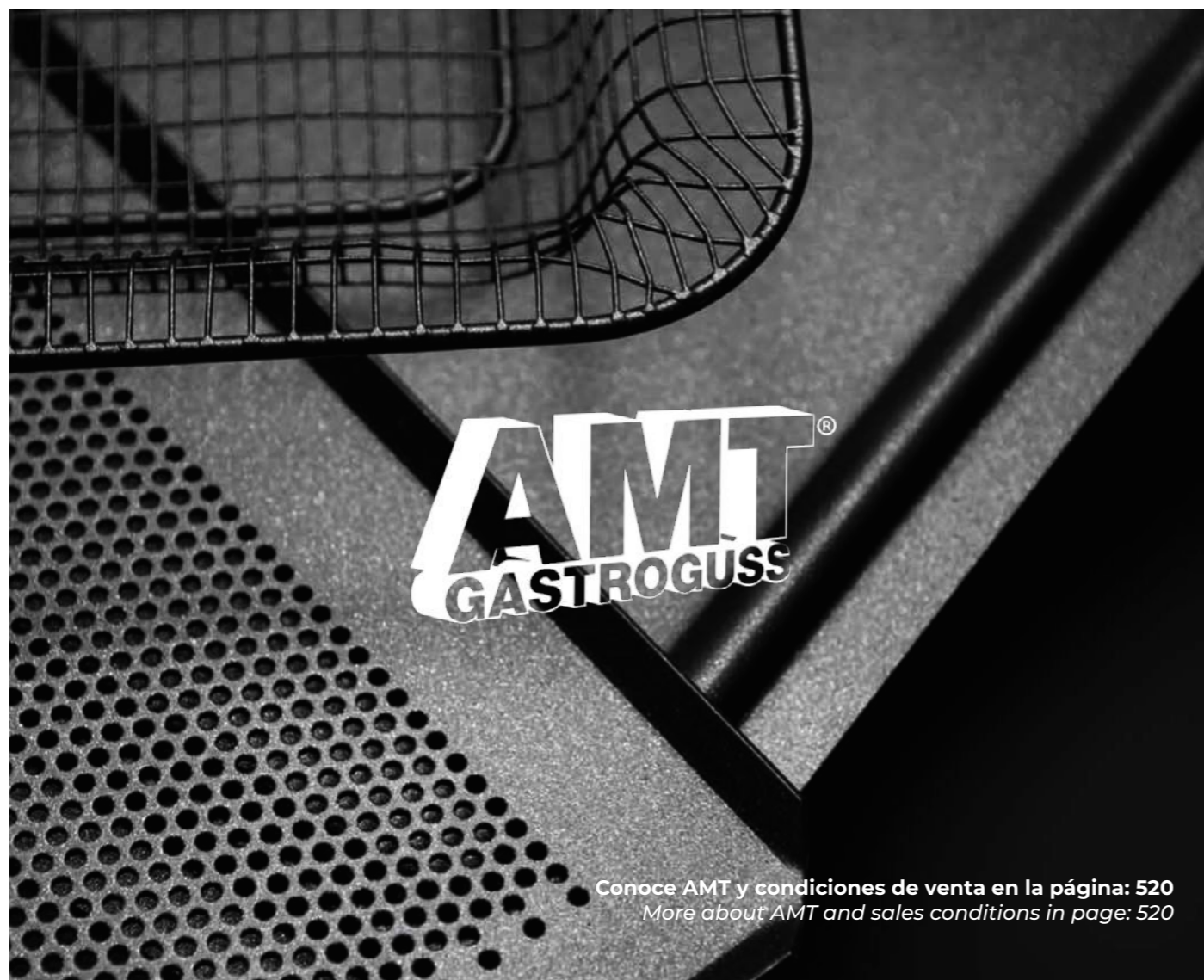

Aluminio Fundido. Cast Aluminium.

Aluminio fundido de alta resistencia hecha por expertos artesanos. Gracias al espesor del aluminio, de los utensilios AMT almacenan más energía y mantiene la temperatura constante durante más tiempo.

Son resistentes a altas temperaturas sin ninguna alteración en su forma.

High-strength cast aluminium made by skilled craftsmen. Thanks to the thickness of the aluminium, AMT cookware stores more energy and maintains a constant temperature for longer.

They are resistant to high temperatures without any alteration in their shape.

Sostenibilidad. Sustainability.

AMT produce de una manera sostenible y respetuosa con el medio ambiente, proporcionando una selección consciente de los productos que va a utilizar durante mucho tiempo, al tiempo que **reduce significativamente su huella de carbono**.

El grosor de 9-10 mm del fondo de las sartenes y ollas garantiza una **gran transferencia de energía y retención del calor**. Esto nos permite aplicar cocciones de una manera más eficiente.

*AMT produced in a sustainable and environmentally friendly manner, providing a conscious selection of products that you will use for a long time, while **significantly reducing your carbon footprint**.*

*9-10 mm thick bottom of our pans and pots **ensures great energy transfer and heat retention**. This allows us to apply firings more efficiently.*

Superficie antiadherente. Non-stick surface.

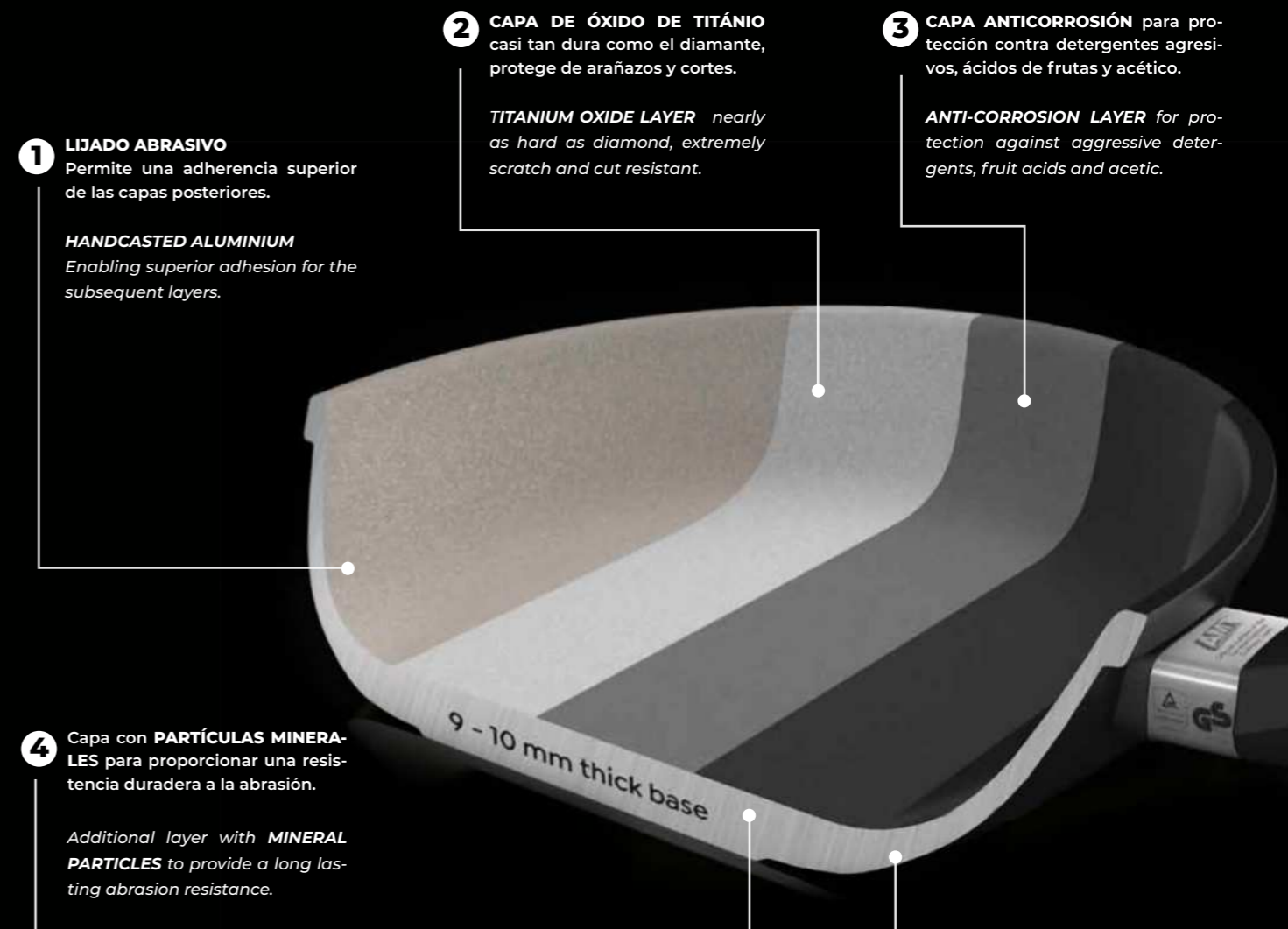

GASTRONORM COOKING

Múltiples soluciones para cocina profesional.
Multiple solutions for professional kitchens.

ESPECIAL HORNOS DE CONVECCIÓN SPECIAL CONVECTION OVENS

Recubrimiento antiadherente de alto rendimiento y de fácil limpieza.

High-performance, easy-to-clean non-stick coating.



260 °C

Resiste a temperaturas de hasta 260°C.

Temperature resistant up to 260°C.



Fácil apilabilidad. Facilita el transporte y almacenaje en buffet y cocinas profesionales.

Easy stackability. Easy transport and storage in buffets and professional kitchens.



Apto para calentar en hornos de convección.

Suitable for heating in convection ovens.

Medidas GN 1/1 y 60x40cm compatibles con hornos de convección.

GN 1/1 and 60x40cm sizes compatible with convection ovens.



Cocción gastronorm / Gastronorm cooking

Bandeja Gn 1/1 Grill & Pizza

Tray Gn 1/1 Grill & Pizza
Plateau Gn 1/1 Grill Et Pizza
Vassoio Gn 1/1 Grill & Pizza
Gn-Backblech 1/1 Grill Und Pizza



| REF. | WxL(mm) | H(mm) | € | MOQ |
|-------|---------|-------|---|-----|
| 11828 | GN 1/1 | 20 | | 1 |
| 11829 | 60x40 | 20 | | 1 |

Bandeja Gn 1/1 Bbq Perforada

Tray Gn 1/1 Perforated Bbq
Plateau Gn 1/1 Bbq Perforé
Vassoio Gn 1/1 Perforato Da Barbecue
Gn-Backblech 1/1 Bbqmit Schlitzen



| REF. | WxL(mm) | H(mm) | € | MOQ |
|-------|---------|-------|---|-----|
| 11830 | GN 1/1 | 20 | | 1 |

Cesta Gn 1/1 Perforada

Gn Perforated Basket
Corbeille Gn 1/1 Perforée
Cestello Gn 1/1 Perforato
Gn-Korb Mit Löchern

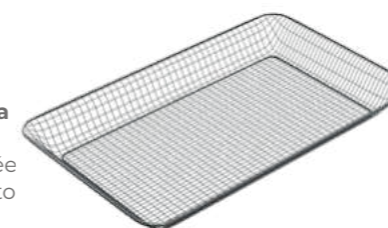

| REF. | WxL(mm) | H(mm) | € | MOQ |
|-------|---------|-------|---|-----|
| 11840 | GN 1/1 | 40 | | 1 |

Bandeja Gn 1/1 Perforada

Gn Tray 1/1 Perforated
Plateau Perforé Gn 1/1
Vassoio Gn 1/1 Accatastabile
Gn-Backblech 1/1 Stapelbar



| REF. | WxL(mm) | H(mm) | € | MOQ |
|-------|---------|-------|---|-----|
| 11841 | GN 1/1 | 30 | | 1 |

Bandeja Gn 1/1 11 Moldes

Gn Tray 1/1 11 Moulds
Plateau Gn 1/1 11 Moules
Vassoio Gn 1/1 Stampi
Gn-Backblech 1/1 Formen



| REF. | WxL(mm) | H(mm) | € | MOQ |
|-------|---------|-------|---|-----|
| 11842 | GN 1/1 | 50 | | 1 |

Bandeja Multiuso Baker

Baker Tray, Utility
Plateau Multiusage Baker
Vassoio Multiuso Baker
Backblech mehrzweck Baker



| REF. | WxL(mm) | H(mm) | € | MOQ |
|-------|---------|-------|---|-----|
| 11843 | GN 1/1 | 20 | | 1 |
| 11844 | 60x40 | 20 | | |

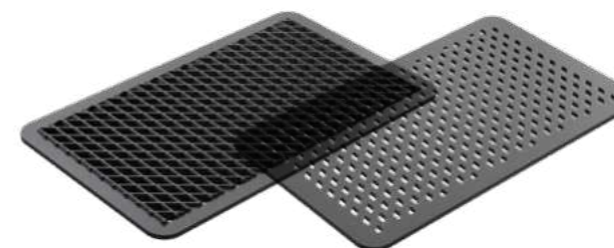

Bandeja Gn 1/1 Bbq & Smooth Perforada

Gn Tray 1/1 Bbq & Smooth, Perforated Plateau Gn 1/1 Bbq Et Smooth Perforé
Vassoio Gn 1/1 Bbq & Smooth Perforata
Gn-Backblech 1/1 Bbq & Smooth Mit Schlitzen

| REF. | WxL(mm) | H(mm) | € | MOQ |
|-------|---------|-------|---|-----|
| 11839 | GN 1/1 | 10 | | 1 |

Cubeta Gn 1/1

Gn Container 1/1
Plateau Gn 1/1
Vassoio Gn 1/1
Gn-Behälter 1/1



| REF. | GN | WxL(mm) | H(mm) | € | MOQ |
|-------|-----|---------|-------|---|-----|
| 11989 | 1/1 | 530x325 | 55 | | 1 |
| 11990 | 1/1 | 530x325 | 100 | | |

GASTRONORM BUFFET

Cocinar y servir en un solo recipiente.
Cook and serve in a single container.



Medidas disponibles
Available sizes:

GASTRONORM

1/1 1/2 1/3 2/3

ALTURAS / HEIGHTS:
2cm / 5,5cm / 10cm



Apto para cocción y regeneración en horno.

Suitable for cooking and regenerating in the oven.



También disponible para inducción.

Also available for induction.

Recipientes con asas para mayor comodidad en el transporte y presentación.

Containers with handles for convenient transport and presentation.



260 °C

Apta a altas temperaturas de hasta 260 °C sin alterar la forma, gracias a la resistencia del aluminio fundido.

Suitable for high temperatures up to 260 °C without altering the shape, thanks to the strength of the cast aluminium.



* Modelos sin asas para opciones donde dificulte la operativa (hornos horizontales, chafings, ...)

Models without handles for options where operation is difficult (horizontal ovens, chafing, ...).

Cubeta Gn Con Asas / Inducción
Gn Container With Handles/Induc.
Plateau Gn Avec Poignées Induc.
Vassoio Gn Con Manici /Induz.
Gn-Behälte Mit Henkel/Induk.



Cubeta Gn Inducción
Gn Container Induc.
Plateau Gn Induc.
Vassoio Gn Induz.
Gn-Behälte Induk.



| REF. | GN | WxL(mm) | H(mm) | € | MOQ |
|-------|-----|---------|-------|---|-----|
| 11862 | 1/1 | 530x325 | 55 | | 1 |
| 11863 | 1/1 | 530x325 | 100 | | 1 |
| 11854 | 1/2 | 265x325 | 55 | | 1 |
| 11851 | 1/3 | 176x325 | 55 | | 1 |
| 11852 | 1/3 | 176x325 | 100 | | 1 |
| 11856 | 2/3 | 354x325 | 55 | | 1 |

| REF. | GN | WxL(mm) | H(mm) | € | MOQ |
|-------|-----|---------|-------|---|-----|
| 11861 | 1/1 | 530x325 | 55 | | 1 |
| 11853 | 1/2 | 265x325 | 55 | | 1 |
| 11855 | 2/3 | 354x325 | 55 | | 1 |

Bandeja Gn Con Asas / Inducción
Gn Container With Handles/Induc.
Plateau Gn Avec Poignées Induc.
Vassoio Gn Con Manici /Induz.
Gn-Behälte mit Henkel/Induk.



Bandeja GN BBQ con asas
Brochette grill
Gril à brochette
Griglia per spiedini
Grill für Spieße



| REF. | GN | WxL(mm) | H(mm) | € | MOQ |
|-------|-----|---------|-------|---|-----|
| 11859 | 1/1 | 530x325 | 20 | | 1 |
| 11857 | 2/3 | 354x325 | 20 | | 1 |

| REF. | GN | WxL(mm) | H(mm) | € | MOQ |
|-------|-----|---------|-------|---|-----|
| 11860 | 1/1 | 530x325 | 20 | | 1 |
| 11858 | 2/3 | 354x325 | 20 | | 1 |

SPEED OVEN ACCESSORIES

Regeneración más rápida y eficiente.
Faster and more efficient regeneration.

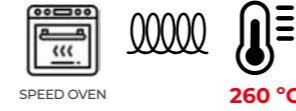

Speed oven

EFICIENCIA. EFFICIENCY.

Distribución rápida y uniforme del calor en toda la superficie de los accesorios. Tiempos de cocción más cortos sin comprometer la calidad.

Fast and even heat distribution on the whole surface of accessories. Shorter cooking times without compromising quality.

UTILIDAD. UTILITY.

Productos perfectos para la cocción y regeneración de una manera más rápida y efectiva.

Perfect products for warming, browning and baking in fast service.

VARIEDAD. VARIETY.

Selección de accesorios de Speed Ovens para una mayor comodidad y seguridad según cada necesidad de operativa de servicio.

Selection of Speed Ovens accessories for convenience and safety according to each service operation need.

Pala Snacks
Snack Scoop
Spatule À Snaks
Paletta Per Snack
Snack-Schaufel



| REF. | WxL(mm) | H(mm) | € | MOQ |
|-------|---------|-------|---|-----|
| 11849 | 425x29 | 10 | | 1 |

Cuenco Cuadrado Snacks
Square Pie Dish Snacks
Bol Carré À Snaks
Recipiente Quadrato Snacks
Quadratische Snack-Schüssel



| REF. | WxL(mm) | H(mm) | € | MOQ |
|-------|---------|-------|---|-----|
| 11850 | 245x15 | 50 | | 1 |

Bandeja Cuadrada Lisa
Square Tray Smooth
Plateau Carré Lisse
Vassoio Quadrato Liscia
Quadratisches Superglatt



| REF. | WxL(mm) | H(mm) | € | MOQ |
|-------|---------|-------|---|-----|
| 11845 | 260x260 | 30 | | 1 |

Bandeja Cuadrada Grill
Square Tray Grill
Plateau Carré Grill
Vassoio Quadrato Grill
Quadratisches Grill



| REF. | WxL(mm) | H(mm) | € | MOQ |
|-------|---------|-------|---|-----|
| 11846 | 260x260 | 30 | | 1 |

Pinza
Tong
Pince
Pinza
Pinzette



| REF. | L(mm) | € | MOQ |
|-------|-------|---|-----|
| 11847 | 200 | | 1 |

Bandeja Cuadrada Grill
Square Tray Grill
Plateau Carré Grill
Vassoio Quadrato Grill
Quadratisches Backblech Gril

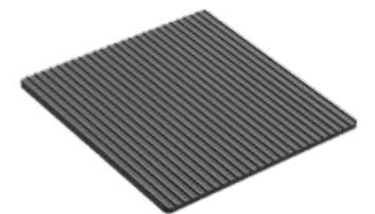

| REF. | WxL(mm) | H(mm) | € | MOQ |
|-------|---------|-------|---|-----|
| 11848 | 292x286 | 10 | | 1 |

OTHERS

Cazuelas de alta capacidad.
High-capacity casseroles.



Otros / Others



260 °C

Soporta temperaturas de hasta 260 °C sin alterar la forma, gracias a la resistencia del aluminio fundido.

Withstands temperatures of up to 260°C without altering shape, thanks to the strength of the cast aluminium.



Conductividad térmica más eficiente gracias al aluminio fundido de 4 mm de grosor.

More efficient thermal conductivity thanks to 4 mm thick cast aluminium.



Superficie antiadherente. De 3 a 4 capas de revestimiento antiadherente y anticorrosión

Non-stick surface. 3 to 4 layers of non-stick and anti-corrosion coating.



Apto para cocción y para calentar en horno.

Suitable for baking and heating in the oven.



Apto para placas de inducción.

Suitable for induction hobs.



Mantiene una temperatura constante por un largo tiempo en toda las superficies.

Maintains a constant temperature for a long time on all surfaces.

Cazuela Gran Capacidad
Stock Pot
Casserole Grande Capacité
Casseroia Grande Capacita'
Grosser Schmortopf



| REF. | Ø(mm) | H(mm) | € | MOQ |
|-------|-------|-------|---|-----|
| 11831 | 380 | 70 | | 1 |

Cazuela Gran Capacidad
Stock Pot
Casserole Grande Capacité
Casseroia Grande Capacita'
Grosser Schmortopf



| REF. | Ø(mm) | H(mm) | € | MOQ |
|-------|-------|-------|---|-----|
| 11832 | 50 | 80 | | 1 |
| 11834 | 65 | 80 | | 1 |
| 11837 | 80 | 100 | | 1 |

Cazuela Gran Capacidad 2 segm.
Stock Pot
Casserole Grande Capacité
Casseroia Grande Capacita'
Grosser Schmortopf



| REF. | Ø(mm) | H(mm) | € | MOQ |
|-------|-------|-------|---|-----|
| 11833 | 50 | 80 | | 1 |
| 11835 | 65 | 80 | | 1 |

Cazuela Gran Capacidad 3 segm.
Stock Pot
Casserole Grande Capacité
Casseroia Grande Capacita'
Grosser Schmortopf



| REF. | Ø(mm) | H(mm) | € | MOQ |
|-------|-------|-------|---|-----|
| 11836 | 65 | 80 | | 1 |
| 11838 | 80 | 100 | | 1 |



Conoce RISOLÍ y condiciones de venta en la página: 520
 More about RISOLÍ and sales conditions in page: 520

La cuidadosa selección de nuestros materiales: Aluminio fundido a presión.
The careful selection of our materials: Die-cast aluminium.



Seleccionamos cuidadosamente las técnicas y los materiales más avanzados para crear nuestros productos. El uso exclusivo de aluminio fundido a presión (una materia prima certificada para uso alimentario) proporciona una distribución óptima y constante del calor, así como una gran resistencia a los diferentes métodos de cocción y un proceso de cocción más natural

We carefully select the most advanced techniques and materials to create our products. The exclusive use of die-cast aluminium (a raw material certified for food use) provides an optimal and constant heat distribution, as well as a high resistance to different cooking methods and a more natural cooking process.

Cocción homogénea.
Homogeneous cooking.

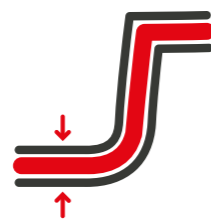

El aluminio fundido a presión tiene excelentes propiedades de conducción del calor y los alimentos se cocinan de manera uniforme sin que se quemen ni se altere su sabor, manteniendo las propiedades nutritivas en cada tipo de alimento.

The die-cast aluminium has excellent heat conduction properties and the food cooks evenly without burning or altering its taste, maintaining the nutritional properties in each type of food.

El aluminio está fundido a presión con un grosor considerable que distribuye el calor de manera uniforme y una base resistente a la deformación.

The aluminium is die-cast with a considerable thickness that distributes heat evenly and a base that is resistant to deformation.

No pierde calor, lo que permite ahorrar energía. Incluso cuando se apaga la fuente de calor, mantiene la temperatura durante otros 10/15 minutos manteniendo los alimentos calientes mientras se sirven en la mesa.

It doesn't lose heat, which saves energy. Even when the heat source is turned off, it maintains the temperature for another 10/15 minutes keeping the food warm while it's being served at the table.



La gama BLACKplus incluye en exclusiva el revestimiento ELDIAMANT PROFILE de última generación, capaz de garantizar una resistencia a las rayadas sin precedentes en los recubrimientos antiadherentes. El cuerpo en aluminio fundido de alto espesor para obtener ligereza, indeformabilidad y mejor distribución del calor, ELDIAMANT PROFILE con partículas minerales para cocinar sin aceite.



ELDIAMANT
PROFILE

The BLACKplus range exclusively includes the latest generation ELDIAMANT PROFILE coating, capable of guaranteeing unprecedented scratch resistance in non-stick coatings. The high thickness cast aluminium body for lightness, non-deformability and better heat distribution, ELDIAMANT PROFILE with mineral particles for oil-free cooking.



40.000
ciclos de uso.



La garantía del producto es de (2+1 años) desde el momento de la compra (presentando el comprobante) y si se respetan las instrucciones de uso. Risolí no se hace responsable de daños causados por un incorrecto uso del producto.

The product is guaranteed (2+1 years) from the moment of purchase (presenting the receipt) and if the instructions for use are followed. Risolí is not responsible for any damage caused by incorrect use of the product.



Sartén fusa

18/10 - 18/10

Espesor 6 - 7 mm

6 - 7 mm thickness.

Mango de acero inoxidable 18/10 termoaislante con 4 remaches.

Stainless steel handle 18/10 heat protection with 4 rivets.

Revestimiento interior Teflon Profile antiadherente resistente al rayado.

Inside non stick coating TeFlon Platinum scratch resistant.

Garantía ECOCAST 3 años.

3 years ECOCAST guarantee.



INOX STAINLESS STEEL 304



Sartén fusa 18/10
Frypan Fusa 18/10
Poele fusa 18/10
Padella fusa 18/10
Pfanne fusa 18/10

ALUMINIO FUNDIDO
CAST ALUMINIUM

| REF. | Ø(mm / inches) | e(mm) | L ₁ (mm) | € | MOQ |
|-------|----------------|-------|---------------------|---|-----|
| 10000 | 240/9,4" | 0,6 | 50 | | 1 |
| 10001 | 280/11" | 0,6 | 52 | | 1 |
| 10002 | 320/12,5" | 0,6 | 58 | | 1 |



INOX STAINLESS STEEL 304



Sartén honda fusa 18/10
Deep frypan Fusa 18/10
Poele profonde fusa 18/10
Padella profonda fusa 18/10
Tiefe pfanne fusa 18/10

ALUMINIO FUNDIDO
CAST ALUMINIUM

| REF. | Ø(mm / inches) | e(mm) | L ₁ (mm) | € | MOQ |
|-------|----------------|-------|---------------------|---|-----|
| 10004 | 240/9,4" | 0,6 | 70 | | 1 |
| 10005 | 280/11" | 0,6 | 70 | | 1 |
| 10006 | 320/12,5" | 0,6 | 80 | | 1 |
| 10007 | 360/14" | 0,6 | 80 | | 1 |



FONDO: Alto espesor para una perfecta difusión del calor.

BOTTOM: High thickness for perfect heat diffusion.

Apto para cocinas de gas, eléctricas, vitrocerámicas y horno.

Suitable for gas, electric, glass-ceramic, oven and induction cookers.

Diseño innovador y exclusivo para un agarre seguro.

Innovative and exclusive design for a secure grip.

Remache exterior especial.

Special external rivet.

Sartén Classica



INOX STAINLESS STEEL 304



Sartén Classica
Frypan Classica
Poele Classica
Padella Classica
Pfanne Classica

ALUMINIO FUNDIDO
CAST ALUMINIUM

| REF. | Ø(mm / inches) | e(mm) | L ₁ (mm) | € | MOQ |
|-------|----------------|-------|---------------------|---|-----|
| 10008 | 240/9,4" | 0,6 | 50 | | 1 |
| 10009 | 280/11" | 0,6 | 52 | | 1 |
| 10010 | 320/12,5" | 0,6 | 58 | | 1 |
| 10011 | 360/14" | 0,6 | 60 | | 1 |



INOX STAINLESS STEEL 304



Sartén honda Classica
Deep frypan Classica
Poele profonde Classica
Padella profonda Classica
Tiefe pfanne Classica

ALUMINIO FUNDIDO
CAST ALUMINIUM

| REF. | Ø(mm / inches) | e(mm) | L ₁ (mm) | € | MOQ |
|-------|----------------|-------|---------------------|---|-----|
| 10012 | 240/9,4" | 0,6 | 70 | | 1 |
| 10013 | 280/11" | 0,6 | 70 | | 1 |
| 10014 | 320/12,5" | 0,6 | 80 | | 1 |
| 10015 | 360/14" | 0,6 | 80 | | 1 |

Sartén Ergo



MANGO
BAQUELITA
BAKELITE
HANDLE
200°C



Sartén Ergo Prof
Frypan Ergo Prof
Poele Ergo Prof
Padella Ergo Prof
Pfanne Ergo Prof

ALUMINIO
FUNDIDO
CAST
ALUMINIUM

| REF. | Ø(mm/inches) | e(mm) | L(mm) | € | MOQ |
|-------|--------------|-------|-------|---|-----|
| 10016 | 200/7,8" | 0,7 | 50 | | 1 |
| 10017 | 240/9,4" | 0,7 | 52 | | 1 |
| 10018 | 280/11" | 0,7 | 58 | | 1 |
| 10019 | 320/12,5" | 0,7 | 60 | | 1 |



Sartén honda Ergo Prof
Deep frying pan Ergo Prof
Poele profonde Ergo Prof
Padella profonda Ergo Prof
Tiefe pfanne Ergo Prof

ALUMINIO
FUNDIDO
CAST
ALUMINIUM

| REF. | Ø(mm/inches) | ml | e(mm) | L(mm) | € | MOQ |
|-------|--------------|-----|-------|-------|---|-----|
| 10020 | 240/9,4" | 200 | 0,9 | 80 | | 1 |
| 10021 | 280/11" | 300 | 0,9 | 85 | | 1 |

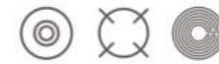

Whitford

Grill mango silicona abatible
Grill "xl" silicone handle
gril manche rabattable
griglia maniglie estraibile
gril ausziehbar griff



| REF. | WxL(mm) | ml | e(mm) | H(mm) | € | MOQ |
|-------|---------|----|-------|-------|---|-----|
| 10811 | 260x330 | - | 0,6 | 50 | | 1 |



Disponibile en 3 colores
Available in 3 colours



Plancha burger
Burger griddle
Plancha burger
Piastra burger
Grillplatte burger

Whitford

| REF. | WxL(mm) | ml | e(mm) | H(mm) | € | MOQ |
|-------|---------|----|-------|-------|---|-----|
| 10073 | 400x240 | - | 0,6 | 30 | | 1 |

MANGO
BAQUELITA
BAKELITE
HANDLE
200°C



Grill asa BK
Grill BK handle
Gril asa BK
Griglia manico BK
Grillgriff BK



| REF. | Ø(mm/inches) | ml | e(mm) | H(mm) | € | MOQ |
|-------|--------------|----|-------|-------|---|-----|
| 10044 | 260x260 | - | 0,7 | 40 | | 1 |

MANGO
BAQUELITA
BAKELITE
HANDLE
200°C



Wok mango BK
Wok BK handle
Wok manche BK
Wok maniglie BK
Wok Griff BK



| REF. | Ø(mm/inches) | ml | e(mm) | H(mm) | € | MOQ |
|-------|--------------|----|-------|-------|---|-----|
| 10057 | 300/11,8" | - | 0,6 | 90 | | 1 |



Horno / Especial Oven / Special

Whitford

Huevo & dulce
Egg & sweet
Oeuf & sucré
Uovo e dolce
Ei & süß



PORCIÓN
INDIVIDUAL
INDIVIDUAL
PORTION

| REF. | Ø(mm/inches) | ml | e(mm) | L (mm) | € | MOQ |
|-------|--------------|----|-------|--------|---|-----|
| 10022 | 140/5,5" | - | 0,5 | 30 | | 1 |

Whitford

Mini finger grill
Mini finger grill
Mini finger grill
Mini finger griglia
Mini finger grillpfanne



PORCIÓN
INDIVIDUAL
INDIVIDUAL
PORTION

| REF. | WxL(mm/inches) | e(mm) | H(mm) | € | MOQ |
|-------|------------------|-------|-------|---|-----|
| 10025 | 320x160/126x6,2" | 0,5 | 30 | | 1 |



Mini cacerola
Mini saucepan
Mini casserole
Mini casseruola
Mini kasserolle



COMPATIBLE CON (P.327)

10064 - 10065



| REF. | Ø(mm/inches) | ml | e(mm) | H(mm) | € | MOQ |
|-------|--------------|-----|-------|-------|---|-----|
| 10023 | 160/6,2" | 100 | 0,5 | 68 | | 1 |
| 10024 | 200/7,8" | 150 | 0,5 | 70 | | 1 |



Cacerola grand gourmet
Grand gourmet saucepan
Casserole grand gourmet
Casseruola grand gourmet
Kasserolle grand gourmet



COMPATIBLE CON (P.327)

10066 - 10067 - 10068 - 10069



| REF. | Ø(mm/inches) | ml | e(mm) | L (mm) | € | MOQ |
|-------|--------------|-----|-------|--------|---|-----|
| 10027 | 240/9,4" | 200 | 0,6 | 70 | | 1 |
| 10028 | 280/11" | 300 | 0,6 | 75 | | 1 |
| 10029 | 320/12,5" | 450 | 0,6 | 85 | | 1 |
| 10030 | 360/14,1" | 550 | 0,6 | 85 | | 1 |



Cacerola alta grand gourmet
Grand gourmet high saucepan
Casserole haute grand gourmet
Casseruola alta grand gourmet
Hohe Kasserolle grand gourmet



COMPATIBLE CON (P.327)

10065 - 10066 - 10067



| REF. | Ø(mm/inches) | ml | e(mm) | L (mm) | € | MOQ |
|-------|--------------|-----|-------|--------|---|-----|
| 10031 | 200/7,8" | 250 | 0,6 | 105 | | 1 |
| 10032 | 240/9,44" | 350 | 0,6 | 106 | | 1 |
| 10033 | 280/11" | 450 | 0,6 | 110 | | 1 |



Cazo 1 mango grand gourmet
Grand gourmet pot 1 handle
Casserole 1 manche grand gourmet
Casseruola 1 mangico grand gourmet
Kasserolle 1 griff grand gourmet



MANGO
BAQUELITA
BAKELITE
HANDLE
200°C

COMPATIBLE CON (P.327)

10064



| REF. | Ø(mm/inches) | ml | e(mm) | L (mm) | € | MOQ |
|-------|--------------|-----|-------|--------|---|-----|
| 10034 | 160/6,2" | 150 | 0,5 | 102 | | 1 |

Aluminio Fundido / Cast Aluminium



Le Pignatte

Cocción lenta / Slow Cooking



Le Pignatte®



Más fácil de limpiar
Easier to clean



Más ligera que el hierro fundido
Lighter than cast iron



Mejor presentación
Better performance



ELDIAMANT
PROFILE

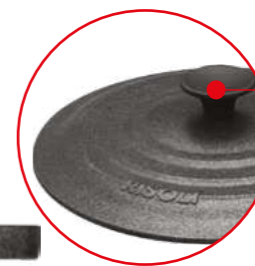

El pomo aguanta temperatura
de hasta 200°C

The knob withstands tempera-
tures up to 200°C.



200°C



Cacerola de cocción lenta "Le Pignatte"
Slow cooking soucepot "Le Pignatte"
Casserole à la mijoteuse "Le Pignatte"
Casseruola a cottura lenta "Le Pignatte"
Kasserolle langsamen Kochen "Le Pignatte"

| REF. | Ø(mm/inches) | ml | e(mm) | L(mm) | € | MOQ |
|-------|--------------|-----|-------|-------|---|-----|
| 10035 | 200/7,8" | 225 | 0,7 | 101 | | 1 |
| 10036 | 240/9,4" | 350 | 0,7 | 106 | | 1 |
| 10037 | 280/11" | 450 | 0,7 | 114 | | 1 |



Horno / Especial
Oven / Special



Ondulación para una mayor circulación del aire en el horno.
Undulation for greater air circulation in the oven.

Whitford

Grill pizza
Grill pizza
Gril pizza
Griglia pizza
Grill pizza



| REF. | WxL(mm) | ml | e(mm) | H(mm) | € | MOQ |
|-------|---------|----|-------|-------|---|-----|
| 10041 | 400x340 | - | 0,8 | 30 | | 1 |

COMPATIBLE
CALIU

Whitford

Grill para pinchos
Brochette grill
Gril à brochette
Griglia per spiedini
Grill für spieße



| REF. | WxL(mm) | ml | e(mm) | H(mm) | € | MOQ |
|-------|---------|----|-------|-------|---|-----|
| 10040 | 470x260 | - | 0,6 | 50 | | 1 |

46 x 25 CM

31 x 25 CM

Whitford

Plancha grill
Servigrill
Plaque de grill
Piastra grigliata
Grillplatte



| REF. | WxL(mm) | ml | e(mm) | H(mm) | € | MOQ |
|-------|---------|----|-------|-------|---|-----|
| 10042 | 460x250 | - | 0,6 | 30 | | 1 |
| 10735 | 460x250 | | 0,6 | 30 | | 1 |



Grill barbecue
Grilled barbecue
Gril barbecue
Piastra barbecue
Grill grillen

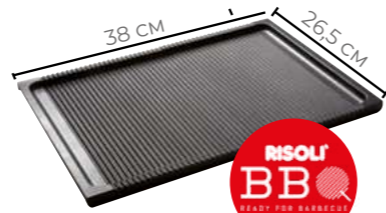

| REF. | WxL(mm) | ml | e(mm) | H(mm) | € | MOQ |
|-------|---------|----|-------|-------|---|-----|
| 10038 | 380x265 | - | 0,6 | 20 | | 1 |

Whitford

Placa grill doble
Dual grill plate
Plaque de grill double
Piastra dual grill
Doppelte grillplatte



| REF. | WxL(mm) | ml | e(mm) | H(mm) | € | MOQ |
|-------|---------|----|-------|-------|---|-----|
| 10071 | 300x225 | - | 0,5 | 20 | | 1 |

Whitford

Grill horno
Oven grill
Gril four
Griglia forno
Grill ofen



| REF. | WxL(mm) | ml | e(mm) | H(mm) | € | MOQ |
|-------|---------|----|-------|-------|---|-----|
| 10072 | 360x180 | - | 0,5 | 18 | | 1 |

Aluminio Fundido / Cast Aluminium

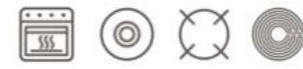

Parrilla



Grill ovalado para pescado
Oval fish grill
Grill à poisson ovale
Pesciera ovale
Ovale Fischpfanne



| REF. | WxL (mm) | ml | € | MOQ |
|-------|----------|----|---|-----|
| 10039 | 460x265 | - | | 1 |



COMPATIBLE
CALIU

Rustidera
Lasagna pan
Plat à rôtir
Rostiera
Lasagneform



| REF. | WxL (mm) | ml | € | MOQ |
|-------|----------|------|---|-----|
| 11604 | 400x250 | 5700 | | 1 |



Tapa vidrio
Glass Lid
Couvercle verre
Coperchio vetro
Glasdeckel

| REF. | Ø(mm/inches) | € | MOQ |
|------------------------|--------------|---|-----|
| BOROSILICATO | | | |
| 10064 | 160/6,2" | | 1 |
| 10065 | 200/7,8" | | 1 |
| 10066 | 240/9,4" | | 1 |
| 10067 | 280/11" | | 1 |
| 10068 | 320/12,5" | | 1 |
| VIDRIO TEMPLADO | | | |
| 10069 | 360/14,1" | | 1 |



Disco inductor universal
Universal inductor disc
Disque inducteur universel
Disco induttore universale
Universal-induktorscheibe

| REF. | Ø(mm) | ml | € | MOQ |
|-------|-------|----|---|-----|
| 10070 | 260 | - | | 1 |



Salvamantel silicona verde
Silicone trivet green
Sottopivetto in silicone verde
Dessous de plat silicone vert
Untersatz aus silikon grün

| REF. | WxL(mm) | H(mm) | € | MOQ |
|-------|---------|-------|---|-----|
| 10813 | 170x170 | 30 | | 4 |
| 10814 | 190x190 | 30 | | 4 |



Set 2 agarraderas silicona negro
Set 2 silicone handle black
Set 2 manici in silicone nero
Set 2 manche en silicone noir
Set 2 silikongriff schwarz

| REF. | € | MOQ |
|-------|---|-----|
| 10812 | | 4 |





MOLDE PARA HORNEAR REPOSTERÍA CREATIVA

BAKING MOLD FOR CREATIVE CAKES

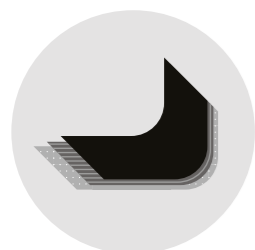

**EXCELENTE
ANTIADHERENTE**
EXCELLENT
NON-STICK



**GRAN ESPESOR,
ROBUSTO**
EXTRA THICK,
EXTREME HARD



**PARA TARTAS
CREATIVAS**
FOR CREATIVE
CAKES

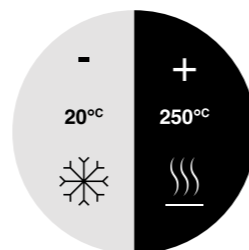

**PERFECTO
DE -20° A 250°**
PERFECT FROM
-20° TO 250°C

Black Plus®
ELDIAMANT®
PROFILE

Los fondos extragrosos y los revestimientos antiadherentes de los moldes garantizan no solo el horneado, gracias a su correcta conducción del calor, sino también asegura que mantengan mejor su forma que otros moldes similares, haciéndolos perfectos también para servir en la mesa.

Extra thick bottoms and non-stick coatings guarantee not just even baking thanks to correct heat conduction, but also ensure the tins keep their shape better than others on the market, making them perfect also for serving at the table.

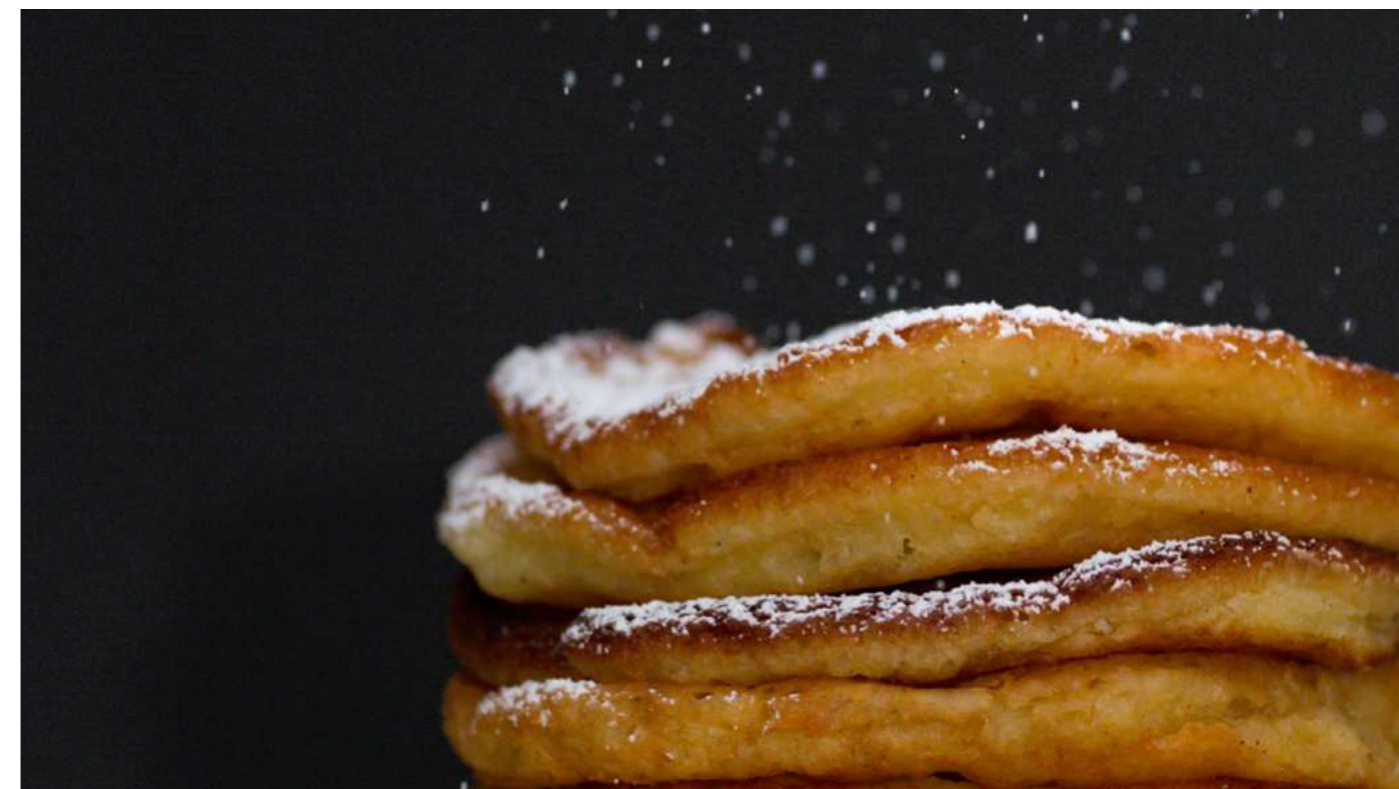

ROYAL D'ALÙ. DESDE 1965.

Diseño: Mínima 2020
Design: Minimal 2020

Material: Aluminio fundido - hecho a mano
Material: Cast Aluminium - Handmade

Capa: Verde, Granito, Perfil
Coating: Green, Granito, Profile

Garantía: 2 años
Warranty: 2 years



Tarta de plato hondo "crostata" 4/6 personas
Deep dish tart "crostata" 4/6 people
Tarte creuse "crostata" 4/6 personnes
Crostata 4/6 persone
Deep dish torte "crostata" 4/6 personen

| REF. | Ø(mm/inches) | ml | € | MOQ |
|-------|--------------|-----|---|-----|
| 10062 | 240 | 200 | | 1 |



Tarta de plato hondo "ciambellone" 6/8 personas
Deep dish tart "ciambellone" 6/8 people
Tartelette "ciambellone" 6/8 personnes
Ciambellone con foro 6/8 persone
"Ciambellone"-torte 6/8 personen

| REF. | Ø(mm/inches) | ml | € | MOQ |
|-------|--------------|-----|---|-----|
| 10063 | 260 | 200 | | 1 |



Sartén pancake con mango BK
Pancake frypan with BK handle
Poêle pancake avec manche BK
Padella pancake manico BK
Pfanne pancake mit BK-griff

| REF. | Ø(mm/inches) | ml | e(mm) | H(mm) | € | MOQ |
|-------|--------------|----|-------|-------|---|-----|
| 10060 | 250/9,8" | - | 65 | 25 | | 1 |



Sartén creps con mango BK
Crepe frying pan with BK handle
Crêpe poêle avec manche BK
Crepe padella manico BK
Pfanne Krepp mit BK-griff

| REF. | Ø(mm/inches) | ml | e(mm) | H(mm) | € | MOQ |
|-------|--------------|----|-------|-------|---|-----|
| 10061 | 280/11" | - | 65 | 23 | | 1 |

Descubre
la plancha
grill GN.



Estructura de placa de aleación de aluminio con conductividad térmica muy alta e indeformable.

Aluminium alloy plate structure with very high thermal conductivity and non-deformable.

Certificado antiadherente de alta calidad.

High quality non-stick certificate.

Zonas de desagüe de cocina para no mezclar los sabores.

Kitchen drainage areas so as not to mix flavours.

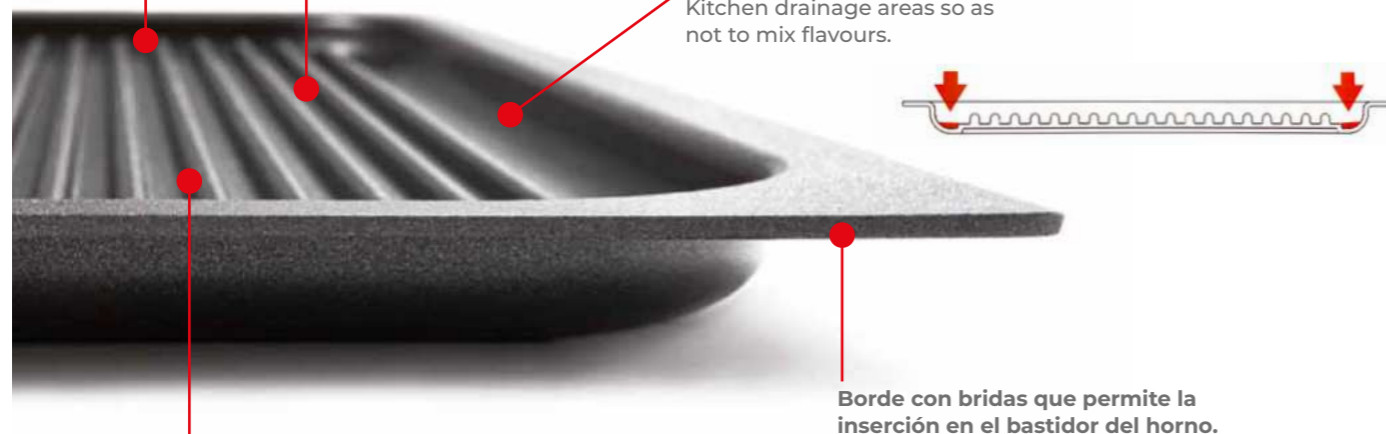

Rayadura y relieves para evitar el efecto fritura.

Scratches and reliefs to avoid the frying effect.

Borde con bridas que permite la inserción en el bastidor del horno.

Flanged edge for insertion into the oven frame.



* Nicola Ostinelli
Proprietario del ristorante Il Diavolo
L'acqua Santa

Plancha grill GN
GN grill
Plaque de cuisson GN
Piastra Griglia GN
Grill Platte GN

| REF. | WxL(mm) | GN | e _(mm) | H _(mm) | € | MOQ |
|-------|---------|-----|-------------------|-------------------|---|-----|
| 10045 | 530x325 | 1/1 | 0,7 | 20 | | 1 |
| 11603 | 235x530 | 2/3 | 0,7 | 20 | | 1 |

CUBETA GN EN ALUMINIO CON ANTIADHERENTE HARD STONE

Aluminium Baking Pans With non-stick coating



GN 1/1

| REF. | WxL(mm) | ml | e _(mm) | H _(mm) | € | MOQ |
|-------|---------|----|-------------------|-------------------|---|-----|
| 10046 | 530x325 | - | 1,5 | 20 | | 1 |
| 10047 | 530x325 | - | 1,5 | 40 | | 1 |
| 10048 | 530x325 | - | 1,5 | 65 | | 1 |

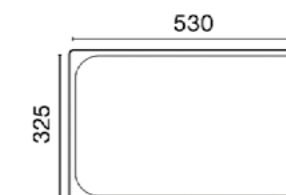

GN 2/3

| REF. | WxL(mm) | ml | e _(mm) | H _(mm) | € | MOQ |
|-------|---------|----|-------------------|-------------------|---|-----|
| 10049 | 355x325 | - | 1,5 | 20 | | 1 |
| 10050 | 355x325 | - | 1,5 | 40 | | 1 |
| 10051 | 355x325 | - | 1,5 | 65 | | 1 |

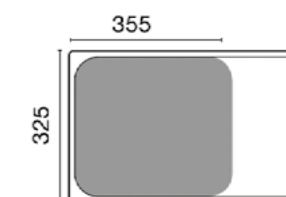

GN 1/2

| REF. | WxL(mm) | ml | e _(mm) | H _(mm) | € | MOQ |
|-------|---------|----|-------------------|-------------------|---|-----|
| 10052 | 265x325 | - | 1,5 | 20 | | 1 |
| 10053 | 265x325 | - | 1,5 | 40 | | 1 |

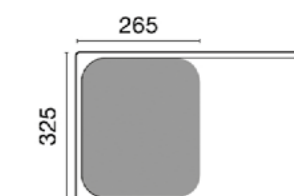



Rustidera
Lasagna pan
Plat à rôtir
Rostiera
Lasagneform



COMPATIBLE
CALIU

ALUMINIO
FUNDIDO
CAST
ALUMINIUM

| REF. | LxW (mm) | € | MOQ |
|-------|----------|---|-----|
| 11604 | 250x400 | | 1 |



Sartén BBQ
BBQ frypan
Poêle BBQ
Padella BBQ
Pfanne BBQ



| REF. | Ø (mm/inches) | ml | e (mm) | H (mm) | € | MOQ |
|-------|---------------|----|--------|--------|---|-----|
| 10058 | 320/11" | - | 6 | 58 | | 1 |



Paellera BBQ
Paella pan BBQ
Poêle à paella BBQ
Paellera BBQ
Paella-pfanne BBQ



| REF. | Ø (mm/inches) | ml | e (mm) | H (mm) | € | MOQ |
|-------|---------------|----|--------|--------|---|-----|
| 10059 | 320/11" | - | 6 | 58 | | 1 |



Paellera mango inox
Inox handle saucepan
Poêle à manche inox
Paellera manico inox
Bratpfanne mit Edelstahlgriff



| REF. | Ø (mm/inches) | ml | e (mm) | H (mm) | € | MOQ |
|-------|---------------|-----|--------|--------|---|-----|
| 10054 | 280/11" | 150 | 6 | 48 | | 1 |
| 10055 | 320/12,5" | 250 | 6 | 52 | | 1 |
| 10056 | 360/14,1" | 350 | 6 | 58 | | 1 |

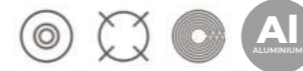

Grill para pinchos
Brochette grill
Gril à brochette
Griglia per spiedini
Grill für spieße



COMPATIBLE
CALIU

| REF. | WxL (mm) | e (mm) | H (mm) | € | MOQ |
|-------|----------|--------|--------|---|-----|
| 10040 | 470x260 | 6 | 50 | | 1 |

Grill horno
Oven grill
Gril four
Griglia forno
Grill ofen



| REF. | WxL (mm) | e (mm) | H (mm) | € | MOQ |
|-------|----------|--------|--------|---|-----|
| 10072 | 360x180 | 5 | 18 | | 1 |

Accesorios BBQ / BBQ Accessories

Grill barbecue
Grilled barbecue
Gril barbecue
Piastra barbecue
BBQ grill

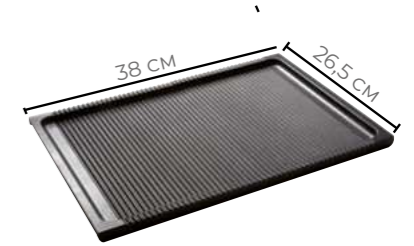

| REF. | WxL (mm) | e (mm) | H (mm) | € | MOQ |
|-------|----------|--------|--------|---|-----|
| 10038 | 380x265 | 6 | 20 | | 1 |

Placa grill doble
Dual grill plate
Plaque de grill double
Piastra dual grill
Doppelte grillplatte



| REF. | WxL (mm) | e (mm) | H (mm) | € | MOQ |
|-------|----------|--------|--------|---|-----|
| 10071 | 300x225 | 5 | 20 | | 1 |



Plancha grill GN
GN grill
Plaque de cuisson GN
Piastra Griglia GN
Grill Platte GN

| REF. | WxL (mm) | GN | e (mm) | H (mm) | € | MOQ |
|-------|----------|-----|--------|--------|---|-----|
| 10045 | 530x325 | 1/1 | 0,7 | 20 | | 1 |
| 11603 | 235x530 | 2/3 | 0,7 | 20 | | 1 |

Cocina / Kitchen

Certificado
contacto
alimentario.



Nuestras cubetas GN de acero AISI 304 son compatibles con las principales marcas GASTRONORM.

El radio de las esquinas más abierto permite una mejor y más fácil apilabilidad y optimiza la capacidad de las cubetas.

Our AISI 304 steel GN trays are compatible with the main GASTRONORM brands.

The more open corner radius allows for better and easier stackability and optimises the capacity of the trays.



Alta calidad garantizada.
High quality guaranteed.



Resistencia a la corrosión.
Corrosion resistance.



Máxima capacidad.
Maximum capacity.

Gastronorm / Cubetas Gastronorm / Cubetas

Tamaños GN / GN Sizes:

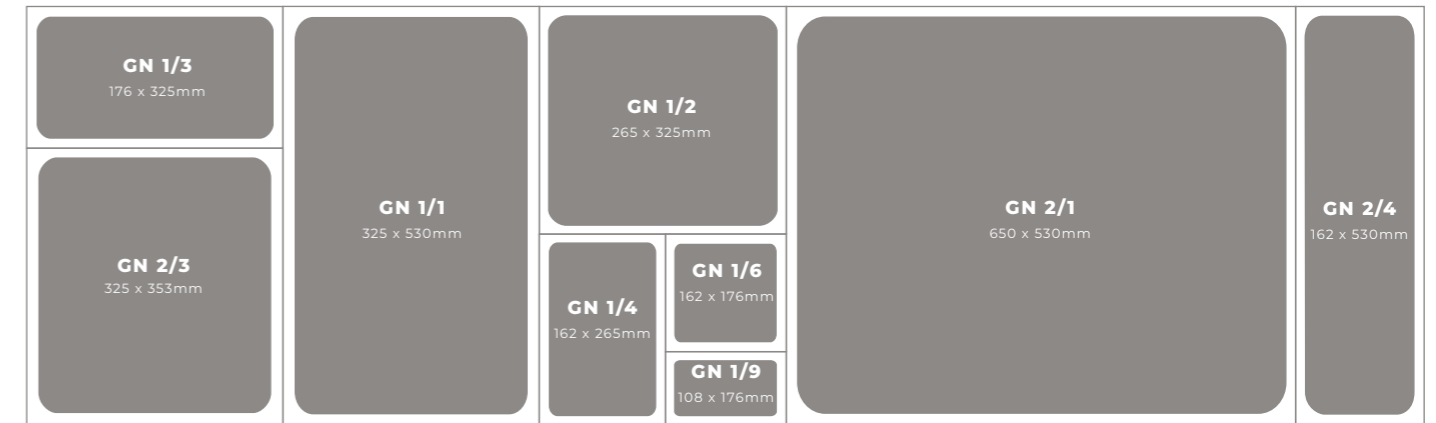

*medidas exteriores / external dimensions

Altura GN / GN High:



Apto horno.
Oven save.



Apto lavavajillas.
Dishwasher save.



Apilable.
Stackable.



-20°C
300°C



Apto contacto
alimentario.
Food contact save.



Apto horno.
Oven save.



Apto lavavajillas.
Dishwasher save.



Apilable.
Stackable.



-20°C
300°C



Apto contacto
alimentario.
Food contact save.

COMPATIBLE CON
LAS PRINCIPALES
MARCAS DEL
MERCADO

COMPATIBLE WITH
THE MAIN BRANDS
ON THE MARKET



El radio de las esquinas más abierto permite una mejor y más fácil apilabilidad y optimiza la capacidad de las cubetas.

The more open corner radius allows for better and easier stackability and optimises the capacity of the trays.

GN 1/1 - 325 X 530 mm



| REF. | H(mm) | e(mm) | LT | € | UE / MOQ |
|-------|-------|-------|------|---|------------------|
| 10147 | 20 | 0,7 | | | 1-0-6-24-120 / 6 |
| 10148 | 40 | 0,7 | | | 1-0-6-24-120 / 6 |
| 10149 | 55 | 0,7 | | | 1-0-6-24-120 / 6 |
| 10150 | 65 | 0,8 | 8,8 | | 1-0-6-24-120 / 6 |
| 11089 | 65 | 0,7 | 8,8 | | 1-0-6-24-120 / 6 |
| 10151 | 100 | 0,7 | 13,7 | | 1-0-6-24-120 / 6 |
| 10153 | 150 | 0,7 | 20 | | 1-0-6-24-120 / 6 |
| 10154 | 200 | 0,7 | 27,8 | | 1-0-6-24-120 / 6 |

GN 1/2 - 265 X 325 mm



| REF. | H(mm) | e(mm) | LT | € | UE / MOQ |
|-------|-------|-------|------|---|------------------|
| 10164 | 20 | 0,7 | | | 1-0-6-24-120 / 6 |
| 10166 | 40 | 0,7 | | | 1-0-6-24-120 / 6 |
| 10168 | 65 | 0,7 | 8,8 | | 1-0-6-24-120 / 6 |
| 10170 | 100 | 0,7 | 13,7 | | 1-0-6-24-120 / 6 |
| 10172 | 150 | 0,7 | 20 | | 1-0-6-24-120 / 6 |
| 10173 | 200 | 0,7 | 27,8 | | 1-0-6-24-120 / 6 |

GN 1/3 - 176 X 325 mm



| REF. | H(mm) | e(mm) | LT | € | UE / MOQ |
|-------|-------|-------|-----|---|----------------|
| 10179 | 20 | 0,7 | | | 1-6-18-0-0 / 6 |
| 10181 | 40 | 0,7 | | | 1-6-18-0-0 / 6 |
| 11905 | 55 | 0,7 | | | 1-6-18-0-0 / 6 |
| 10183 | 65 | 0,7 | 2,4 | | 1-6-18-0-0 / 6 |
| 10185 | 100 | 0,7 | 3,5 | | 1-6-18-0-0 / 6 |
| 10187 | 150 | 0,7 | 5,4 | | 1-6-18-0-0 / 6 |
| 10188 | 200 | 0,7 | 7,2 | | 1-0-6-0-0 / 6 |

GN 1/4 - 162 X 265 mm

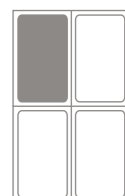

| REF. | H(mm) | e(mm) | LT | € | UE / MOQ |
|-------|-------|-------|-----|---|----------------|
| 10190 | 20 | 0,7 | | | 1-6-24-0-0 / 6 |
| 10432 | 40 | 0,7 | | | 1-6-24-0-0 / 6 |
| 10192 | 65 | 0,7 | 1,7 | | 1-6-24-0-0 / 6 |
| 10194 | 100 | 0,7 | 2,5 | | 1-6-24-0-0 / 6 |
| 10195 | 150 | 0,7 | 3,8 | | 1-6-24-0-0 / 6 |
| 10196 | 200 | 0,7 | 4,8 | | 1-6-24-0-0 / 6 |



GN 1/6 - 162 X 176 mm



| REF. | H(mm) | e(mm) | LT | € | UE / MOQ |
|-------|-------|-------|-----|---|----------------|
| 10197 | 65 | 0,7 | 1 | | 1-6-36-0-0 / 6 |
| 10199 | 100 | 0,7 | 1,5 | | 1-6-36-0-0 / 6 |
| 10200 | 150 | 0,7 | 2,3 | | 1-6-36-0-0 / 6 |
| 10201 | 200 | 0,7 | 3,3 | | 1-6-36-0-0 / 6 |

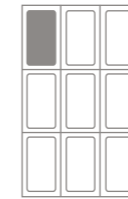

GN 1/9 - 108 X 176 mm



| REF. | H(mm) | e(mm) | LT | € | UE / MOQ |
|-------|-------|-------|-----|---|----------------|
| 10203 | 65 | 0,7 | 0,6 | | 1-6-48-0-0 / 6 |
| 10205 | 100 | 0,7 | 0,8 | | 1-6-48-0-0 / 6 |

GN 2/1 - 650 X 530 mm



| REF. | H(mm) | e(mm) | LT | € | UE / MOQ |
|-------|-------|-------|------|---|------------------|
| 10141 | 20 | 0,8 | | | 1-0-6-24-120 / 6 |
| 10142 | 40 | 0,8 | | | 1-0-6-24-120 / 6 |
| 10143 | 65 | 0,8 | 8,8 | | 1-0-6-24-120 / 6 |
| 10144 | 100 | 0,8 | 13,7 | | 1-0-6-24-120 / 6 |
| 10145 | 150 | 0,8 | 20 | | 1-0-6-24-120 / 6 |
| 10146 | 200 | 0,8 | 27,8 | | 1-0-6-24-120 / 6 |

GN 2/4 - 162 X 530 mm



| REF. | H(mm) | e(mm) | LT | € | UE / MOQ |
|-------|-------|-------|-----|---|----------------|
| 10175 | 65 | 0,7 | 0,7 | | 1-6-24-0-0 / 6 |
| 10176 | 100 | 0,7 | 0,7 | | 1-6-24-0-0 / 6 |
| 10177 | 150 | 0,7 | 0,8 | | 1-6-24-0-0 / 6 |

GN 2/3 - 325 X 353 mm



| REF. | H(mm) | e(mm) | LT | € | UE / MOQ |
|-------|-------|-------|-----|---|----------------|
| 10155 | 20 | 0,7 | 0,7 | | 1-6-24-0-0 / 6 |
| 10157 | 40 | 0,7 | 0,7 | | 1-6-24-0-0 / 6 |
| 10159 | 65 | 0,7 | 0,8 | | 1-6-24-0-0 / 6 |
| 10160 | 100 | 0,7 | | | 1-6-24-0-0 / 6 |
| 10161 | 150 | 0,7 | | | 1-6-24-0-0 / 6 |
| 10162 | 200 | 0,7 | | | 1-6-24-0-0 / 6 |

Fondo perforado
Perforated bottom
Egouttoirs pour bacs
Falso fondo forato
Abtropfgitter



Perfil divisorio gastronorm
Adaptable bars
Barrettes de composition
Separatore
Adapter



| REF. | W(mm) | L(mm) | e(mm) | FORMATO | € |
|-------|-------|-------|-------|---------|---|
| 10206 | 470 | 590 | 0,7 | GN 2/1 | |
| 10207 | 469 | 269 | 0,7 | GN 1/1 | |
| 10209 | 271 | 211 | 0,7 | GN 1/2 | |
| 10210 | 266 | 116 | 0,7 | GN 1/3 | |
| 10211 | 118 | 106 | 0,7 | GN 1/6 | |

| REF. | FORMATO | e(mm) | € |
|-------|---------|-------|---|
| 10212 | GN 1/1 | 0,7 | |
| 10213 | GN 1/2 | 0,7 | |

GN 1/1 - Perforated - Perforé - Forate - Perforiert - 325 X 530 mm

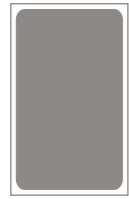

| REF. | H(mm) | e(mm) | LT | € | UE / MOQ |
|-------|-------|-------|------|---|------------------|
| 10220 | 20 | 0,7 | | | 1-0-6-24-120 / 6 |
| 10221 | 40 | 0,7 | | | 1-0-6-24-120 / 6 |
| 10222 | 55 | 0,7 | | | 1-0-6-24-120 / 6 |
| 10223 | 65 | 0,7 | 8,8 | | 1-0-6-24-120 / 6 |
| 10224 | 100 | 0,7 | 13,7 | | 1-0-6-24-120 / 6 |
| 10225 | 150 | 0,7 | 20 | | 1-0-6-24-120 / 6 |
| 10226 | 200 | 0,7 | 27,8 | | 1-0-6-24-120 / 6 |

GN 1/2 - Perforated - Perforé - Forate - Perforier - 265 X 325 mm

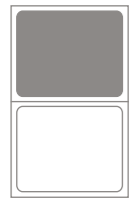

| REF. | H(mm) | e(mm) | LT | € | UE / MOQ |
|-------|-------|-------|------|---|------------------|
| 10234 | 65 | 0,7 | 8,8 | | 1-0-6-24-120 / 6 |
| 10235 | 100 | 0,7 | 13,7 | | 1-0-6-24-120 / 6 |
| 10236 | 150 | 0,7 | 20 | | 1-0-6-24-120 / 6 |
| 10237 | 200 | 0,7 | 27,8 | | 1-0-6-24-120 / 6 |

GN 1/3 - Perforated - Perforé - Forate - Perforier - 176 X 325 mm



| REF. | H(mm) | e(mm) | LT | € | UE / MOQ |
|-------|-------|-------|-----|---|----------------|
| 10238 | 40 | 0,7 | | | 1-6-18-0-0 / 6 |
| 10239 | 65 | 0,7 | 2,4 | | 1-6-18-0-0 / 6 |
| 10240 | 100 | 0,7 | 3,5 | | 1-6-18-0-0 / 6 |
| 10241 | 150 | 0,7 | 5,4 | | 1-6-18-0-0 / 6 |
| 10242 | 200 | 0,7 | 7,2 | | 1-6-18-0-0 / 6 |

GN 2/1 - Perforated - Perforé - Forate - Perforier - 650 X 530 mm



| REF. | H(mm) | e(mm) | LT | € | UE / MOQ |
|-------|-------|-------|-----|---|----------------|
| 10214 | 20 | 0,8 | | | 1-6-24-0-0 / 6 |
| 10215 | 40 | 0,8 | | | 1-6-24-0-0 / 6 |
| 10216 | 65 | 0,8 | 1,7 | | 1-6-24-0-0 / 6 |
| 10217 | 100 | 0,8 | 2,5 | | 1-6-24-0-0 / 6 |
| 10218 | 150 | 0,8 | 3,8 | | 1-6-24-0-0 / 6 |
| 10219 | 200 | 0,8 | 4,8 | | 1-6-24-0-0 / 6 |

GN 2/3 - Perforated - Perforé - Forate - Perforier - 325 X 353 mm



| REF. | H(mm) | e(mm) | LT | € | UE / MOQ |
|-------|-------|-------|-----|---|----------------|
| 10227 | 20 | 0,7 | | | 1-6-24-0-0 / 6 |
| 10228 | 40 | 0,7 | | | 1-6-24-0-0 / 6 |
| 10230 | 65 | 0,7 | 1,7 | | 1-6-24-0-0 / 6 |
| 10231 | 100 | 0,7 | 2,5 | | 1-6-24-0-0 / 6 |
| 10232 | 150 | 0,7 | 3,8 | | 1-6-24-0-0 / 6 |
| 10233 | 200 | 0,7 | 4,8 | | 1-6-24-0-0 / 6 |



Apto para horno.
Oven safe.

GN / Inox AISI 304 - 18/10
GN / Stainless Steel 304 - 18/10

Tapa GN

GN Lid - Couvercle GN - Coperchio GN - GN-deckel - 162 X 176 mm



| REF. | GN | e(mm) | € | UE / MOQ |
|-------|-----|-------|---|---------------|
| 10243 | 1/1 | 0,7 | | 1-0-6-0-0 / 6 |
| 11912 | 2/1 | 0,8 | | 1-0-6-0-0 / 6 |
| 10245 | 2/3 | 0,7 | | 1-0-6-0-0 / 6 |
| 10247 | 1/2 | 0,7 | | 1-0-6-0-0 / 6 |
| 10249 | 1/3 | 0,7 | | 1-0-6-0-0 / 6 |
| 10251 | 1/4 | 0,7 | | 1-0-6-0-0 / 6 |
| 10253 | 1/6 | 0,7 | | 1-0-6-0-0 / 6 |
| 10255 | 1/9 | 0,7 | | 1-0-6-0-0 / 6 |

Tapa GN cierre hermético

GN hermetic lid - Couvercle étanche GN - Coperchio ermetico GN - GN-steck-deckell

NEW



| REF. | GN | e(mm) | € | UE / MOQ |
|-------|-----|-------|---|---------------|
| 10258 | 1/1 | 0,7 | | 1-0-6-0-0 / 6 |
| 10259 | 1/2 | 0,7 | | 1-0-6-0-0 / 6 |
| 10260 | 1/3 | 0,7 | | 1-0-6-0-0 / 6 |
| 10261 | 1/4 | 0,7 | | 1-0-6-0-0 / 6 |
| 10262 | 1/6 | 0,7 | | 1-0-6-0-0 / 6 |

Tapa GN orificio asas

GN lid with hole for handles - Couvercle GN avec trou pour poignées - Coperchio GN con foro per maniglie - GN-deckel Lock für Griffe

NEW



| REF. | GN | e(mm) | € | UE / MOQ |
|-------|-----|-------|---|----------------|
| 10263 | 1/1 | 0,7 | | 1-0-6-0-0 / 6 |
| 10265 | 1/2 | 0,7 | | 1-6-12-0-0 / 6 |
| 10266 | 1/3 | 0,7 | | 1-6-18-0-0 / 6 |
| 10267 | 1/4 | 0,7 | | 1-6-24-0-0 / 6 |
| 10268 | 1/6 | 0,7 | | 1-6-36-0-0 / 6 |

Tapa GN orificio cucharón

GN lid with ladle hole - Couvercle GN avec trou pour louche - Coperchio GN con foro mestolo - GN-deckel loch kelle 1/1

NEW



| REF. | GN | e(mm) | € | UE / MOQ |
|-------|-----|-------|---|----------------|
| 10269 | 1/1 | 0,7 | | 1-0-6-0-0 / 6 |
| 10270 | 1/2 | 0,7 | | 1-6-12-0-0 / 6 |
| 10271 | 1/3 | 0,7 | | 1-6-18-0-0 / 6 |
| 10272 | 1/4 | 0,7 | | 1-6-24-0-0 / 6 |
| 10273 | 1/6 | 0,7 | | 1-6-36-0-0 / 6 |

Tapa GN sin asa

GN flat lid without handle - Couvercle plat GN sans poignée - Coperchio piatto GN senza manico - GN-Flachdeckel ohne Griff

NEW



| REF. | GN | e(mm) | € | UE / MOQ |
|-------|-----|-------|---|---------------|
| 10256 | 1/1 | 0,7 | | 1-0-6-0-0 / 6 |
| 10257 | 1/2 | 0,7 | | 1-0-6-0-0 / 6 |

INOX
STAINLESS
STEEL
201



Apto horno.
Oven save.



Apto lavavajillas.
Dishwasher save.



Apilable.
Stackable.



-20°C
300°C



Apto contacto
alimentario.
Food contact save.

COMPATIBLE CON
LAS PRINCIPALES
MARCAS DEL
MERCADO
COMPATIBLE WITH ALL
MAJOR BRANDS ON THE
MARKET



USO
RECOMENDADO
EN BUFFET

RECOMMENDED
BUFFET USE



Medida estampada en la esquina

Measurement stamped on the corner

Esquinas reforzadas

reinforced corners

Apilable

Stackable



Modelo perforado perfecto para el
drenaje de líquidos y cocción al va-
por.

Perforated model perfect for drain-
ing liquids and steaming.

GN 1/1 - 325 X 530 mm



| REF. | H(mm) | e(mm) | LT | € | UE / MOQ |
|-------|-------|-------|------|---|------------------|
| 10566 | 20 | 0,7 | | | 1-0-6-24-264 / 6 |
| 10567 | 40 | 0,7 | | | 1-0-6-24-264 / 6 |
| 10568 | 55 | 0,7 | | | 1-0-6-24-192 / 6 |
| 10569 | 65 | 0,8 | 8,8 | | 1-0-6-24-192 / 6 |
| 10839 | 65 | 0,7 | 8,8 | | 1-0-6-24-120 / 6 |
| 10570 | 100 | 0,7 | 13,7 | | 1-0-6-24-120 / 6 |
| 10571 | 150 | 0,7 | 20 | | 1-0-6-24-120 / 6 |
| 10572 | 200 | 0,7 | 27,8 | | 1-0-6-24-96 / 6 |

GN 1/2 - 265 X 325 mm



| REF. | H(mm) | e(mm) | LT | € | UE / MOQ |
|-------|-------|-------|-----|---|-------------------|
| 10573 | 20 | 0,7 | | | 1-6-12-48-528 / 6 |
| 10574 | 40 | 0,7 | | | 1-6-12-48-528 / 6 |
| 10575 | 65 | 0,7 | 4 | | 1-6-12-48-336 / 6 |
| 10576 | 100 | 0,7 | 6,1 | | 1-6-12-48-240 / 6 |
| 10577 | 150 | 0,7 | 9,2 | | 1-6-12-48-192 / 6 |
| 10578 | 200 | 0,7 | 12 | | 1-6-12-48-144 / 6 |

GN 1/3 - 176 X 325 mm



| REF. | H(mm) | e(mm) | LT | € | UE / MOQ |
|-------|-------|-------|-----|---|-------------------|
| 10579 | 20 | 0,7 | | | 1-6-18-72-360 / 6 |
| 10580 | 40 | 0,7 | | | 1-6-18-72-360 / 6 |
| 10581 | 65 | 0,7 | 2,4 | | 1-6-18-72-26 / 6 |
| 10582 | 100 | 0,7 | 3,5 | | 1-6-18-72-144 / 6 |
| 10583 | 150 | 0,7 | 5,4 | | 1-6-18-72-144 / 6 |
| 10584 | 200 | 0,7 | 7,2 | | 1-6-18-72-144 / 6 |

GN 1/4 - 162 X 265 mm



| REF. | H(mm) | e(mm) | LT | € | UE / MOQ |
|-------|-------|-------|-----|---|-------------------|
| 10585 | 20 | 0,7 | | | 1-6-24-96-480 / 6 |
| 10586 | 40 | 0,7 | | | 1-6-24-96-480 / 6 |
| 10587 | 65 | 0,7 | 1,7 | | 1-6-24-72-216 / 6 |
| 10588 | 100 | 0,7 | 2,5 | | 1-6-24-96-192 / 6 |
| 10589 | 150 | 0,7 | 3,8 | | 1-6-24-96-192 / 6 |
| 10590 | 200 | 0,7 | 4,8 | | 1-6-24-96-96 / 6 |



**Certificado
contacto
alimentario.**



-20°C
300°C



GN 1/6 - 162 X 176 mm



| REF. | H(mm) | e(mm) | LT | € | UE / MOQ |
|-------|-------|-------|-----|---|----------------|
| 10591 | 65 | 0,7 | 1 | | 1-6-36-0-0 / 6 |
| 10592 | 100 | 0,7 | 1,5 | | 1-6-36-0-0 / 6 |
| 10593 | 150 | 0,7 | 2,3 | | 1-6-36-0-0 / 6 |
| 10594 | 200 | 0,7 | 3,3 | | 1-6-36-0-0 / 6 |

GN 1/9 - 108 X 176 mm

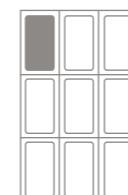

| REF. | H(mm) | e(mm) | LT | € | UE / MOQ |
|-------|-------|-------|-----|---|----------------|
| 10595 | 65 | 0,7 | 0,6 | | 1-6-48-0-0 / 6 |
| 10596 | 100 | 0,7 | 0,8 | | 1-6-48-0-0 / 6 |

GN 1/1 Perforada - Perforated - Perforé - Forate - Perforiert - 325 x 530 mm



| REF. | H(mm) | e(mm) | € | UE / MOQ |
|-------|-------|-------|---|---------------|
| 10617 | 65 | 0,7 | | 1-0-6-0-0 / 6 |
| 10618 | 100 | 0,7 | | 1-0-6-0-0 / 6 |
| 10619 | 150 | 0,7 | | 1-0-6-0-0 / 6 |
| 10620 | 200 | 0,7 | | 1-0-6-0-0 / 6 |

GN 1/2 Perforada - Perforated - Perforé - Forate - Perforiert - 265 X 325 mm



| REF. | H(mm) | e(mm) | € | UE / MOQ |
|-------|-------|-------|---|----------------|
| 10621 | 65 | 0,7 | | 1-6-12-0-0 / 6 |
| 10622 | 100 | 0,7 | | 1-6-12-0-0 / 6 |

Tapa GN inox
GN lid - Couvercle GN - Coperchio GN - GN-deckel



INOX STAINLESS STEEL 201

| REF. | GN | e _(mm) | € | UE / MOQ |
|-------|-----|-------------------|---|----------------|
| 10630 | 1/1 | 0,7 | | 1-0-6-0-0 / 6 |
| 10632 | 1/2 | 0,7 | | 1-6-12-0-0 / 6 |
| 10633 | 1/3 | 0,7 | | 1-6-18-0-0 / 6 |
| 10634 | 1/4 | 0,7 | | 1-6-24-0-0 / 6 |
| 10635 | 1/6 | 0,7 | | 1-6-36-0-0 / 6 |
| 10636 | 1/9 | 0,7 | | 1-6-48-0-0 / 6 |

Tapa GN cierre hermético
GN hermetic lid - Couvercle étanche GN - Coperchio ermetico GN - GN-steck-deckell

Válvula para facilitar la apertura.

Valve for easy opening.



INOX STAINLESS STEEL 201

| REF. | GN | e _(mm) | € | UE / MOQ |
|-------|-----|-------------------|---|----------------|
| 10637 | 1/1 | 0,7 | | 1-0-6-0-0 / 6 |
| 10638 | 1/2 | 0,7 | | 1-6-12-0-0 / 6 |
| 10639 | 1/3 | 0,7 | | 1-6-18-0-0 / 6 |
| 10640 | 1/4 | 0,7 | | 1-6-24-0-0 / 6 |
| 10641 | 1/6 | 0,7 | | 1-6-36-0-0 / 6 |

INOX STAINLESS STEEL 201

Doble fondo perforado
Perforated bottom
Egouttoirs pour bacs
Falso fondo forato
Abtropfgitter



| REF. | FORMATO | e _(mm) | € | UE / MOQ |
|-------|---------|-------------------|---|-----------------|
| 10612 | GN 1/1 | 0,7 | | 1-0-10-0-0 / 10 |

INOX STAINLESS STEEL 201

Perfil divisorio GN
Adaptable bars
Barrettes de composition
Separatore
Adapter



| REF. | FORMATO | e _(mm) | € | UE / MOQ |
|-------|---------|-------------------|---|------------------|
| 10614 | GN 1/1 | 0,7 | | 1-0-120-0-0 / 12 |
| 10615 | GN 1/2 | 0,7 | | 1-0-120-0-0 / 12 |

Rueda de untar inox

Stainless steel spread wheel
Roue tartiner en acier inoxydable
Ruota per spalmare in acciaio inossidabile
Butterrad aus Edelstahl



| REF. | W _(mm) | L _(mm) | H _(mm) | € |
|-------|-------------------|-------------------|-------------------|---|
| 11602 | 160 | 175 | 125 | |

Parrilla horno pastelera
Pastry oven grill 60x40
Gril au four pâtisserie 60x40
Griglia forno pasticceria 60x40
Backofengrill 60x40

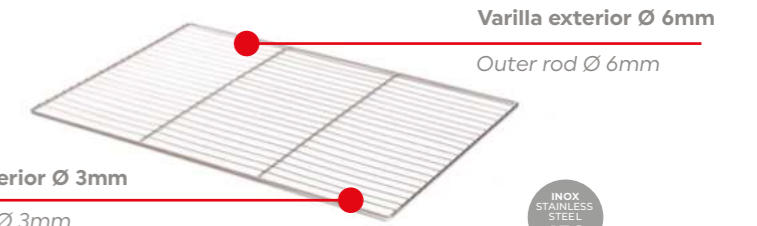

Varilla interior Ø 3mm
Inner rod Ø 3mm

Varilla exterior Ø 6mm
Outer rod Ø 6mm

INOX STAINLESS STEEL 430

| REF. | W _(mm) | L _(mm) | € | UE / MOQ |
|-------|-------------------|-------------------|---|----------------|
| 11014 | 600 | 400 | | 1-6-12-0-0 / 6 |

Parrilla horno GN 1/1
Oven grill gn 1/1
Gril au four gn 1/1
Griglia forno gn 1/1
Backofengrill gn 1/1

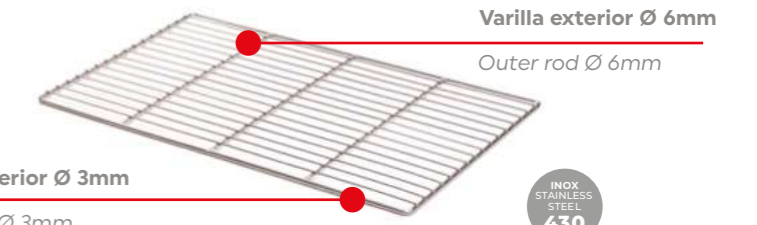

Varilla interior Ø 3mm
Inner rod Ø 3mm

Varilla exterior Ø 6mm
Outer rod Ø 6mm

INOX STAINLESS STEEL 430

| REF. | W _(mm) | L _(mm) | € | UE / MOQ |
|-------|-------------------|-------------------|---|----------------|
| 11015 | 325 | 530 | | 1-6-12-0-0 / 6 |



NEW

Carro Servicio
Serving Trolley
Chariot Service
Carrello Da Servizio
Servierwagen

INOX STAINLESS STEEL 201

| REF. | LEVELS | W _(mm) | L _(mm) | H _(mm) | € | UE / MOQ |
|-------|--------|-------------------|-------------------|-------------------|---|---------------|
| 11774 | 2 | 860 | 540 | 940 | | 0-0-1-0-0 / 1 |
| 11775 | 3 | 860 | 540 | 940 | | 0-0-1-0-0 / 1 |

NEW

Carro Racks Alto
Rack Trolley High
Chariot À Rack Élevé
Carrello Rack Alto
Hoher Tablettwagen Für



INOX STAINLESS STEEL 201

| REF. | LEVELS | W _(mm) | L _(mm) | H _(mm) | € | UE / MOQ |
|-------|--------|-------------------|-------------------|-------------------|---|---------------|
| 11773 | 7 | 510 | 1700 | 560 | | 0-0-1-0-0 / 1 |



NEW

GN / Carros
GN / Trolley



Ruedas pivotantes con freno en 2 de ellas.

Swivel castors with brakes on 2 of them.



Guía en "S", que permite una doble posición de las bandejas y mayor optimización del espacio.

S' guide, which allows double positioning of the trays and greater optimisation of space.



Varilla de seguridad bilateral para bloquear las bandejas.

Safety rod on the side to lock the trays.



GN 1/1

18 NIVELES
18 LEVELS



GN 1/1

9 NIVELES
9 LEVELS



GN 2/1

18 NIVELES
18 LEVELS



60x40 CM

18 NIVELES
18 LEVELS

Ligeros. Fabricados en acero inoxidable AISI 201.
Lightweight. Made of AISI 201 stainless steel.

Resistentes. Soportan hasta 150 kg.
Resistant. Supports up to 150 kg.

Fácil montaje.
Easy assembly.

Carro Portabandejas Gn
Gn Container Trolley
Chariot Porte-Plateaux Gn
Carrello Portavassoi Gn
Gn-Tablett-/Regalwagen

INOX
STAINLESS
STEEL
201

| REF. | SIZE | LAYERS | W(mm) | L(mm) | H(mm) | € | UE / MOQ |
|-------|--------|--------|-------|-------|-------|---|---------------|
| 11769 | GN 1/1 | 18 | 380 | 550 | 1735 | | 0-0-1-0-0 / 1 |
| 11956 | GN 1/1 | 9 | 380 | 550 | 1000 | | 0-0-1-0-0 / 1 |
| 11770 | GN 2/1 | 18 | 590 | 670 | 1735 | | 0-0-1-0-0 / 1 |
| 11771 | 60x40 | 18 | 470 | 620 | 1735 | | 0-0-1-0-0 / 1 |



336 RACKS

- 336 CESTAS Y EXTENDERS
- 338 MONTADOS
- 340 COMPLEMENTOS

342 CONTENEDORES ISOTÉRMICOS

THERMOBOX

- 344 CARGADOR FRONTAL
- 347 CONTENEDORES



Racks industriales robustos para lavar, almacenar y transportar cualquier tipo de plato, vaso, copa, cubertería, etc.

El borde superior y la forma de los fondos están hechos para apilarlos de forma fácil y firme.

Los extensores permiten alcanzar la altura ideal para el almacenamiento y lavado.

Robust industrial racks for washing, storing and transporting any type of plate, glass, cup, glassware, cutlery, etc.

The top edge and the shape of the bottoms are made for easy and firm stacking.

The extenders allow to reach the ideal height for storage and washing.



Fabricado en PP de alta calidad, apto para contacto alimentario, el mejor material contra productos químicos y altas temperaturas (hasta 100°C)

Made of high quality PP, suitable for food contact, the best material against chemicals and high temperatures (up to 100°C)

Rejillas abiertas para un perfecto lavado y secado

Open grids for perfect washing and drying

Las asas y las esquinas redondeadas, lo hacen seguro y fácil de manejar

Easily to handle four sides.

El borde superior y la forma de los fondos están hechos para apilarlos de forma fácil y firme

The top edge and the shape of the bottoms are made for easy and firm stacking

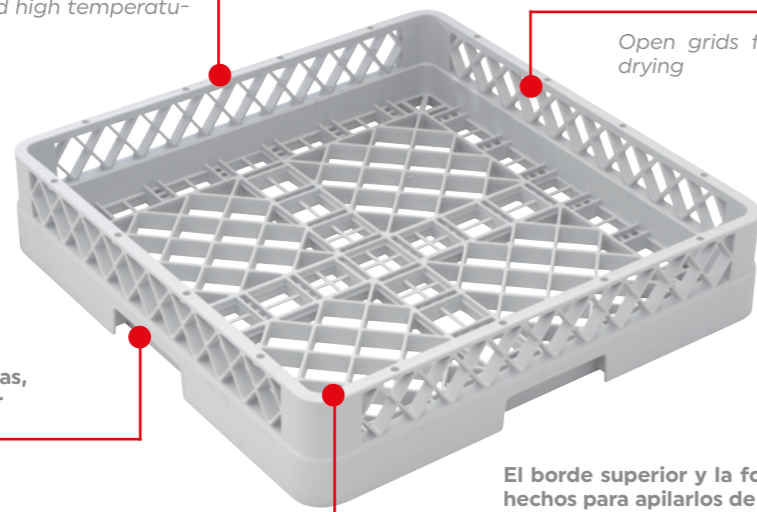

Racks.



Cesta de lavado universal

Universal rack
Universal rack
Rack universale
Universal rack



| REF. | MEDIDA EXTERNA | | MEDIDA INTERNA | | € | UE / MOQ |
|-------|----------------|-------|----------------|-------|---|---------------|
| | W(mm) | L(mm) | W(mm) | L(mm) | | |
| 11039 | 500 | 500 | 476 | 476 | | 1-0-6-0-0 / 6 |

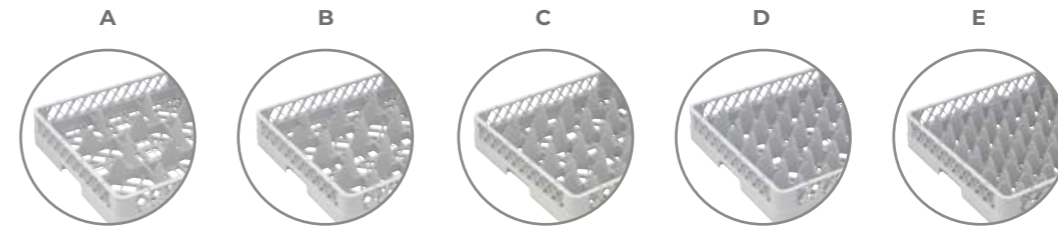

Cesta de lavado compartimento / Rack compartiment / Rack compartiment / Rack scomparto / Rack fächer

| REF. | MEDIDA EXTERNA | | MEDIDA INTERNA | | COMPARTIMENTOS | € | UE / MOQ |
|---------|----------------|-------|----------------|-------|----------------|---|---------------|
| | W(mm) | L(mm) | W(mm) | L(mm) | | | |
| A 11040 | 500 | 500 | 151 | 151 | 9 | | 1-0-6-0-0 / 6 |
| B 11041 | 500 | 500 | 115 | 115 | 16 | | 1-0-6-0-0 / 6 |
| C 11042 | 500 | 500 | 88 | 88 | 25 | | 1-0-6-0-0 / 6 |
| D 11043 | 500 | 500 | 73 | 73 | 36 | | 1-0-6-0-0 / 6 |
| E 11044 | 500 | 500 | 62 | 62 | 49 | | 1-0-6-0-0 / 6 |

Extender universal

Universal extender
Universal extender
Extender universale
Universal extender



| REF. | MEDIDA EXTERNA | | MEDIDA INTERNA | | € | UE / MOQ |
|-------|----------------|-------|----------------|-------|---|-----------------|
| | W(mm) | L(mm) | W(mm) | L(mm) | | |
| 11048 | 500 | 500 | 476 | 476 | | 1-0-12-0-0 / 12 |

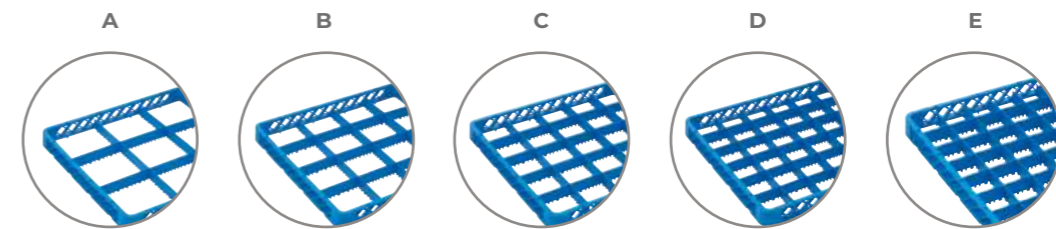

Extender compartimentos / Extender compartiment / Extender compartimen / Extender scomparto / Extender fächer

| REF. | MEDIDA EXTERNA | | MEDIDA INTERNA | | COMPARTIMENTOS | € | UE / MOQ |
|---------|----------------|-------|----------------|-------|----------------|---|-----------------|
| | W(mm) | L(mm) | W(mm) | L(mm) | | | |
| A 11049 | 500 | 500 | 151 | 151 | 9 | | 1-0-12-0-0 / 12 |
| B 11050 | 500 | 500 | 115 | 115 | 16 | | 1-0-12-0-0 / 12 |
| C 11051 | 500 | 500 | 88 | 88 | 25 | | 1-0-12-0-0 / 12 |
| D 11052 | 500 | 500 | 73 | 73 | 36 | | 1-0-12-0-0 / 12 |
| E 11053 | 500 | 500 | 62 | 62 | 49 | | 1-0-12-0-0 / 12 |



4 EXT. 256 mm

3 EXTENDERS. 214 mm

2 EXTENDERS. 172 mm

1 EXTENDER. 130 mm

BASE RACK. 88 mm

GUÍA DE MEDIDAS / GUIDE TO MEASURE

- Monta tu propia altura según tus necesidades.
Set your own height according to your needs.
- Fácil sistema de montaje y que permite adaptar los racks a tus productos.
Easy assembly system that allows you to adapt the racks to your products.
- Se pueden añadir tantos suplementos como se desee.
You can add as many supplements as you wish.
- Una vez montados no se pueden desmontar.
Once assembled, they cannot be disassembled.

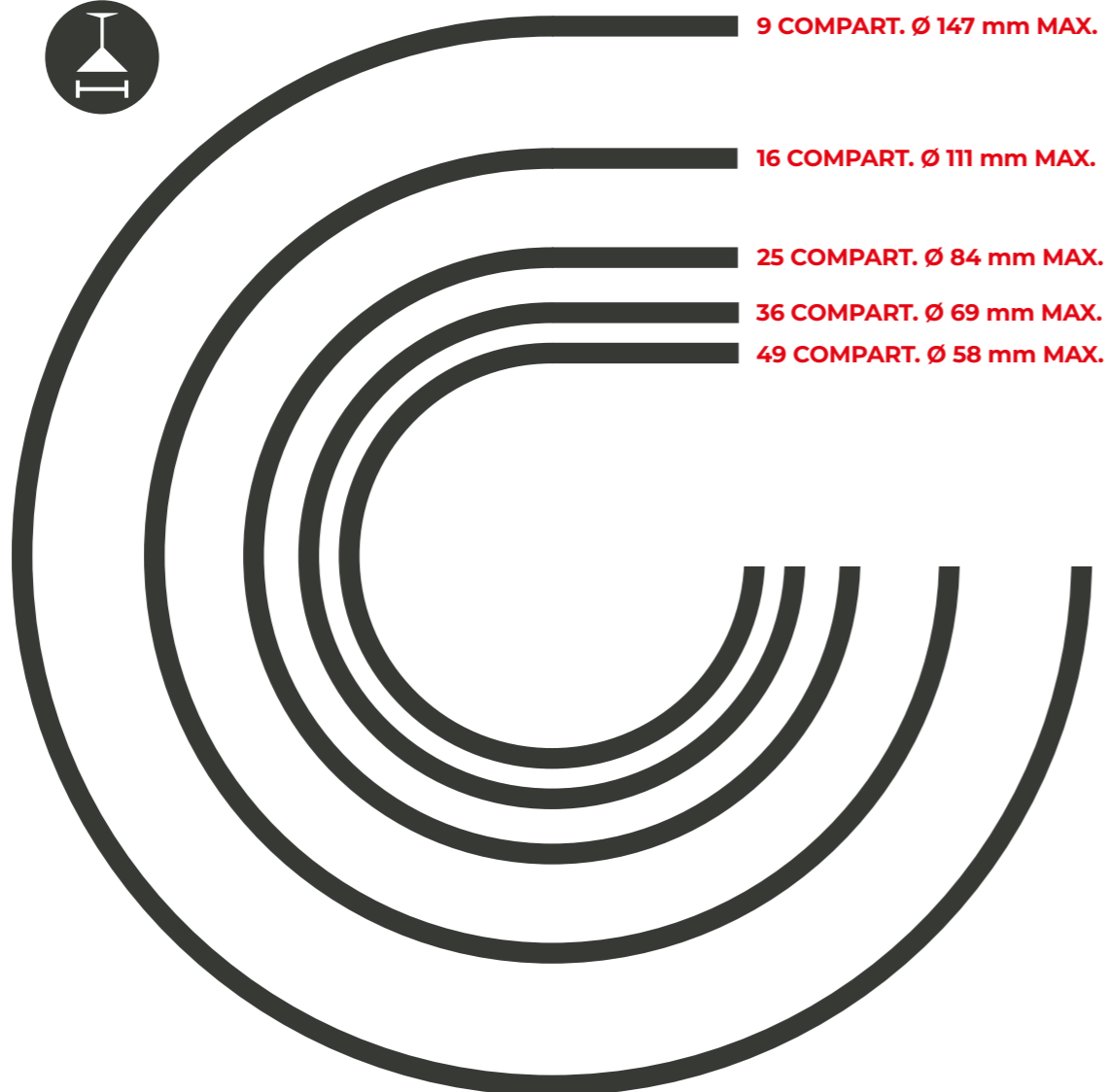
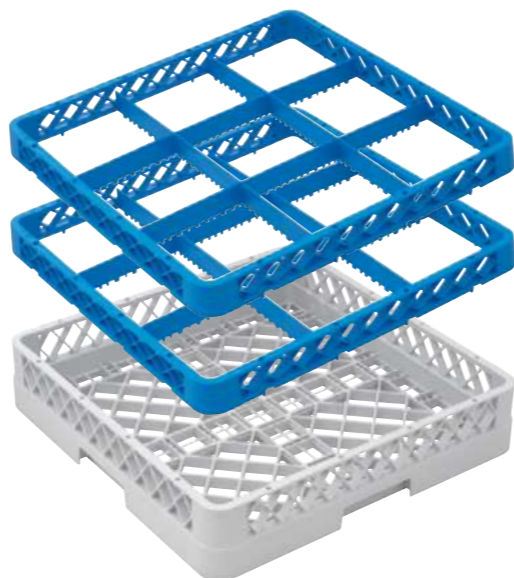

100°C



Ø 147mm MAX.

PACK cestas de lavado 9 compartimentos

PACK rack 9 compartment
PACK rack 9 compartment
PACK rack 9 scomparto
PACK rack 9 fächer



| REF. | EXTENDER | ALTURA | € | UE / MOQ |
|-------|----------|--------|---|---------------|
| 11145 | +1 | 130 | | 1-0-6-0-0 / 6 |
| 11146 | +2 | 172 | | 1-0-6-0-0 / 6 |
| 11147 | +3 | 214 | | 1-0-6-0-0 / 6 |
| 11148 | +4 | 256 | | 1-0-6-0-0 / 6 |
| 11149 | +5 | 298 | | 1-0-6-0-0 / 6 |



Ø 84mm MAX.

PACK cestas de lavado 25 compartimentos

PACK rack 25 compartment
PACK rack 25 compartment
PACK rack 25 scomparto
PACK rack 25 fächer



| REF. | EXTENDER | ALTURA | € | UE / MOQ |
|-------|----------|--------|---|---------------|
| 11155 | +1 | 130 | | 1-0-6-0-0 / 6 |
| 11156 | +2 | 172 | | 1-0-6-0-0 / 6 |
| 11157 | +3 | 214 | | 1-0-6-0-0 / 6 |
| 11158 | +4 | 256 | | 1-0-6-0-0 / 6 |
| 11159 | +5 | 298 | | 1-0-6-0-0 / 6 |



Ø 58mm MAX.

PACK cestas de lavado 49 compartimentos

PACK rack 49 compartment
PACK rack 49 compartment
PACK rack 49 scomparto
PACK rack 49 fächer



| REF. | EXTENDER | ALTURA | € | UE / MOQ |
|-------|----------|--------|---|---------------|
| 11165 | +1 | 130 | | 1-0-6-0-0 / 6 |
| 11166 | +2 | 172 | | 1-0-6-0-0 / 6 |
| 11167 | +3 | 214 | | 1-0-6-0-0 / 6 |
| 11168 | +4 | 256 | | 1-0-6-0-0 / 6 |
| 11169 | +5 | 298 | | 1-0-6-0-0 / 6 |

Montados abiertos Open assembled



Ø 111mm MAX.

PACK cestas de lavado 16 compartimentos

PACK rack 16 compartment
PACK rack 16 compartment
PACK rack 16 scomparto
PACK rack 16 fächer



| REF. | EXTENDER | ALTURA | € | UE / MOQ |
|-------|----------|--------|---|---------------|
| 11150 | +1 | 130 | | 1-0-6-0-0 / 6 |
| 11151 | +2 | 172 | | 1-0-6-0-0 / 6 |
| 11152 | +3 | 214 | | 1-0-6-0-0 / 6 |
| 11153 | +4 | 256 | | 1-0-6-0-0 / 6 |
| 11154 | +5 | 298 | | 1-0-6-0-0 / 6 |



Ø 69mm MAX.

PACK cestas de lavado 36 compartimentos

PACK rack 36 compartment
PACK rack 36 compartment
PACK rack 36 scomparto
PACK rack 36 fächer



| REF. | EXTENDER | ALTURA | € | UE / MOQ |
|-------|----------|--------|---|---------------|
| 11160 | +1 | 130 | | 1-0-6-0-0 / 6 |
| 11161 | +2 | 172 | | 1-0-6-0-0 / 6 |
| 11162 | +3 | 214 | | 1-0-6-0-0 / 6 |
| 11163 | +4 | 256 | | 1-0-6-0-0 / 6 |
| 11164 | +5 | 298 | | 1-0-6-0-0 / 6 |

Pack 10 clips para cestas

Pack 10 rack clip
Pack 10 rack clip
Pack 10 rack clip
Pack 10 rack clip



| REF. | COLOR | W(mm) | L(mm) | € | UE / MOQ |
|-------|-------|-------|-------|---|-------------------|
| 11059 | ○ | 20 | 0,7 | | 1-0-100-0-0 / 100 |
| 11060 | ● | 20 | 0,7 | | 1-0-100-0-0 / 100 |
| 11061 | ● | 20 | 0,7 | | 1-0-100-0-0 / 100 |
| 11062 | ● | 20 | 0,7 | | 1-0-100-0-0 / 100 |
| 11063 | ● | 20 | 0,7 | | 1-0-100-0-0 / 100 |
| 11064 | ● | 20 | 0,7 | | 1-0-100-0-0 / 100 |
| 11065 | ● | 20 | 0,7 | | 1-0-100-0-0 / 100 |



Cesta de lavado para cubertería
 Rack for cutlery
 Rack pour les couverts
 Rack per posate
 Rack für besteck



| REF. | W(mm) | L(mm) | € | UE / MOQ |
|-------|-------|-------|---|---------------|
| 11045 | 500 | 500 | | 1-0-6-0-0 / 6 |

Cesta de lavado para bandejas
 Rack for trays
 Rack pour plateaux
 Rack per vassoio
 Rack für tablett



| REF. | W(mm) | L(mm) | € | UE / MOQ |
|-------|-------|-------|---|---------------|
| 11046 | 500 | 500 | | 1-0-6-0-0 / 6 |

Cesta de lavado para vajilla
 Rack for plates
 Rack pour les plats
 Rack per piatti
 Rack für teller



| REF. | W(mm) | L(mm) | € | UE / MOQ |
|-------|-------|-------|---|---------------|
| 11047 | 500 | 500 | | 1-0-6-0-0 / 6 |

Tapa para cesta de lavado
 Rack lid
 Rack couvercle
 Rack coperchio
 Rack deckel



| REF. | W(mm) | L(mm) | € | UE / MOQ |
|-------|-------|-------|---|-----------------|
| 11076 | 500 | 500 | | 1-0-12-0-0 / 12 |

Cesta para cubertería
 Rack for cutlery
 Rack pour les couverts
 Rack per posate
 Rack für besteck



| REF. | W(mm) | L(mm) | COMPARTIMENTOS | € | UE / MOQ |
|-------|-------|-------|----------------|---|-------------------|
| 11055 | | | 1 | | 1-0-150-0-0 / 150 |
| 11054 | 430 | 205 | 8 | | 1-0-10-0-0 / 10 |

Asa para cesta cubertería
 Handle for rack for cutlery
 Poignée pour rack pour les couverts
 Manico per rack per posate
 Griff für rack für besteck



| REF. | W(mm) | L(mm) | € | UE / MOQ |
|-------|-------|-------|---|-----------------|
| 11079 | 500 | 500 | | 1-0-10-0-0 / 10 |

Carro para cesta de lavado sin asa
 Rack trolley without handle
 Rack chariot sans poignée
 Rack carrello senza maniglia
 Rack wagen ohne griff



| REF. | W(mm) | L(mm) | € | UE / MOQ |
|-------|-------|-------|---|---------------|
| 11077 | 500 | 500 | | 1-0-1-0-0 / 1 |

Carro para cesta de lavado con asa
 Rack trolley with handle
 Rack chariot avec poignée
 Rack carrello con maniglia
 Rack wagen mit griff



| REF. | W(mm) | L(mm) | € | UE / MOQ |
|-------|-------|-------|---|---------------|
| 11078 | 500 | 500 | | 1-0-1-0-0 / 1 |



INOX
 STAINLESS
 STEEL
 201

Carro Racks Alto
 Rack Trolley High
 Chariot À Rack Élevé
 Carrello Rack Alto
 Hoher Tablettwagen Für



| REF. | CAPACIDAD | W(mm) | L(mm) | H(mm) | € | UE / MOQ |
|-------|-----------|-------|-------|-------|---|---------------|
| 11773 | 7 | 560 | 510 | 1735 | | 1-0-6-0-0 / 6 |

Especial para lavavajillas de barra.
 Specially for countertop dishwashers

Rack 35,5 x 35,5
 Rack
 Rack
 Rack
 Rack



| REF. | W(mm) | L(mm) | H(mm) | € | UE / MOQ |
|-------|-------|-------|-------|---|---------------|
| 11616 | 355 | 355 | 150 | | 1-0-6-0-0 / 6 |

Rack 40 x 40
 Rack
 Rack
 Rack
 Rack



| REF. | W(mm) | L(mm) | H(mm) | € | UE / MOQ |
|-------|-------|-------|-------|---|---------------|
| 11617 | 400 | 400 | 150 | | 1-0-6-0-0 / 6 |



Empresa alemana fundada en 2001. Líder del mercado europeo con más de 100 cajas de EPP diferentes para el transporte de productos frescos, calientes o fríos.

German company founded in 2001. European market leader with more than 100 different EPP boxes for the transport of fresh, hot or cold products.



Conoce THERMOBOX y condiciones de venta en la página: 520
More about THERMOBOX and sales conditions in page: 520

Asa resistente para transportarla con una sola mano.

Sturdy handle for carrying with one hand.

Caja térmica adecuada que encaja perfectamente y es fácil de usar.

Proper cool box that fits perfectly and is easy to use.

Tapa hermética fácil de abrir y cerrar.

Airtight lid easy to open and close.





Construcción sólida de una sola pieza
Solid one-piece construction

Forma compacta
Compact design

Puerta abatible
Hinged door

Borde de agarre práctico
Handy grip edges

Apilable y ligero
Stackable and lightweight

Cierres y bisagras metálicos
Metal locking and hinges

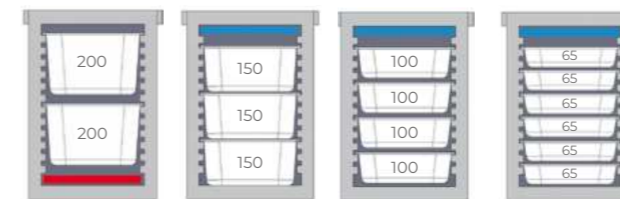

Contenedor isotérmico carga frontal GN 93-12
Thermobox frontloader GN 93-12
Conteneur isotherme à ouverture frontale GN 93-12
Contentitore isothermico per carico frontale GN 93-12
Thermobox frontlader GN 93-12

| REF. | COLOR | OUTSIDE | | | INSIDE | | | CARRILES(mm) | V(litros) | € |
|-------|-------|---------|-------|-------|--------|-------|-------|--------------|-----------|---|
| | | W(mm) | L(mm) | H(mm) | W(mm) | L(mm) | H(mm) | | | |
| 10416 | ● | 440 | 645 | 625 | 335 | 530 | 525 | 12 - 32 | 93 | |

Set Rueda + Base
Wheels + Base Set
Kit Roue + Base
Set Ruota+ Base
Set Rad + Base



| REF. | W(mm) | L(mm) | H(mm) | € |
|-------|-------|-------|-------|---|
| 11762 | 400 | 600 | 180 | |



Contenedor isotérmico carga frontal GN 69-9
Thermobox frontloader GN 69-9
Conteneur isotherme à ouverture frontale GN 69-9
Contentitore isothermico per carico frontale GN 69-9
Thermobox frontlader GN 69-9

| REF. | COLOR | OUTSIDE | | | INSIDE | | | CARRILES(mm) | V(litros) | € |
|-------|-------|---------|-------|-------|--------|-------|-------|--------------|-----------|---|
| | | W(mm) | L(mm) | H(mm) | W(mm) | L(mm) | H(mm) | | | |
| 10417 | ● | 450 | 660 | 490 | 335 | 530 | 390 | 9 - 38 | 69 | |

Set Rueda + Base
Wheels + Base Set
Kit Roue + Base
Set Ruota+ Base
Set Rad + Base

| REF. | W(mm) | L(mm) | H(mm) | € |
|-------|-------|-------|-------|---|
| 11763 | 400 | 600 | 180 | |



GN
SIZE

Contenedor isotérmico GN 1/1 PREMIUM
Thermobox GN 1/1 PREMIUM
Conteneur isotherme GN 1/1 PREMIUM
Contentitore isothermico GN 1/1 PREMIUM
Thermobox GN 1/1 PREMIUM

| REF. | W(mm) | OUTSIDE | | W(mm) | INSIDE | | V(litros) | € |
|-------|-------|---------|-------|-------|--------|-------|-----------|---|
| | | L(mm) | H(mm) | | L(mm) | H(mm) | | |
| 10409 | 400 | 600 | 180 | 337 | 538 | 117 | 21 | |
| 10410 | 400 | 600 | 230 | 337 | 538 | 167 | 30 | |
| 10411 | 400 | 600 | 280 | 337 | 538 | 217 | 39 | |
| 10412 | 400 | 600 | 320 | 337 | 538 | 257 | 46 | |
| 10413 | 400 | 600 | 400 | 337 | 538 | 337 | 61 | |

Cooling Top Gn 1/1 Premium
Cooling Top Gn 1/1 Premium
Plaque Réfrigérante Gn 1/1 Premium
Piano Di Raffreddamento Gn 1/1 Premium
Gn-Kühlaufsatz 1/1 Premium

| REF. | W(mm) | L(mm) | H(mm) | € |
|-------|-------|-------|-------|---|
| 11764 | 400 | 600 | 180 | |



GN
SIZE

Contenedor isotérmico GN 1/1 DELUXE
Thermobox GN 1/1 DELUXE
Conteneur isotherme GN 1/1 DELUXE
Contentitore isothermico GN 1/1 DELUXE
Thermobox GN 1/1 DELUXE

| REF. | W(mm) | OUTSIDE | | W(mm) | INSIDE | | V(litros) | € |
|-------|-------|---------|-------|-------|--------|-------|-----------|---|
| | | L(mm) | H(mm) | | L(mm) | H(mm) | | |
| 10414 | 400 | 675 | 290 | 325 | 535 | 215 | 37 | |
| 10415 | 400 | 675 | 335 | 325 | 535 | 260 | 45 | |



Cooling Top Gn 1/1 Deluxe
Cooling Top Gn 1/1 Deluxe
Plaque Réfrigérante Gn 1/1 Deluxe
Piano Di Raffreddamento Gn 1/1 Deluxe
Gn-Kühlaufsatz 1/1 Deluxe

| REF. | W(mm) | L(mm) | H(mm) | € |
|-------|-------|-------|-------|---|
| 11765 | 400 | 600 | 180 | |



Placa de calor
Hot Pack
Plaque chauffante
Piastra riscaldante
Wärme-akku

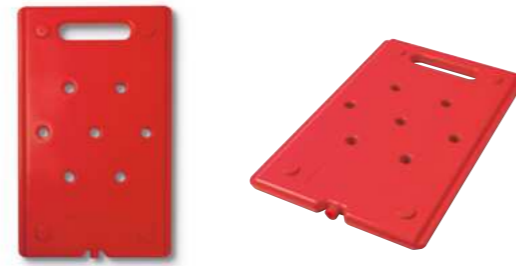

| REF. | W(mm) | L(mm) | H(mm) | FORMATO | € |
|-------|-------|-------|-------|---------|---|
| 10423 | 325 | 530 | 25 | GN 1/1 | |

Calentamiento en el horno (max. 30min a 85°C) y baño maría (max. 30min).
Heating in the oven (max. 30min at 85°C), microwave and bain-marie (max. 30min).

Placa de frío
Cold pack
Plaque eutectique
Piastra eutetica
Kühl-akku

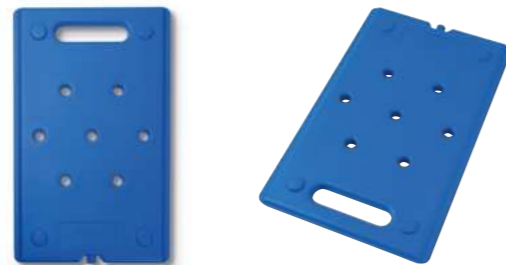

| REF. | W(mm) | L(mm) | H(mm) | FORMATO | € |
|-------|-------|-------|-------|---------|---|
| 10424 | 325 | 530 | 25 | GN 1/1 | |

Refrigeración en el congelador (max. -12°C).
Cooling in the freezer (max. -12°C).



Contenedor isotérmico SHOPPING
Thermobox SHOPPING
Conteneur isotherme SHOPPING
Contentitore isotermico SHOPPING
Thermobox SHOPPING

| REF. | COLOR | W(mm) | OUTSIDE L(mm) | H(mm) | W(mm) | INSIDE L(mm) | H(mm) | FORMATO | V(litros) | € |
|-------|-------|-------|---------------|-------|-------|--------------|-------|---------|-----------|---|
| 10420 | ● | 285 | 360 | 365 | 220 | 300 | 310 | GN 1/4 | 20 | |

Caja para las mejores soluciones logísticas. Tamaño de embalaje optimizado, apilable con los contenedores más comunes, adecuado para contenedores de tamaño GN.

Box for best logistical solutions! Optimized packaging size, stackable with most common stacking containers, suitable for GN size containers.



Contenedor isotérmico BOXER
Thermobox BOXER
Conteneur isotherme BOXER
Contentitore isotermico BOXER
Thermobox BOXER



| REF. | W(mm) | OUTSIDE L(mm) | H(mm) | W(mm) | INSIDE L(mm) | H(mm) | V(litros) | € |
|-------|-------|---------------|-------|-------|--------------|-------|-----------|---|
| 10422 | 395 | 595 | 290 | 340 | 540 | 230 | 42 | |

Tamaño cuadrado optimizado. Con asas empotradas y tapa hermética. Para recipientes GN 2/3, pizza o pasteles.

Optimized square size. With recessed grips, tight fitting lid. For containers GN 2/3, pizza or cakes.



Contenedor isotérmico pizza BOXER
Thermobox pizza BOXER
Conteneur isotherme pizza BOXER
Contentitore isotermico pizza BOXER
Thermobox pizza BOXER



| REF. | W(mm) | OUTSIDE L(mm) | H(mm) | W(mm) | INSIDE L(mm) | H(mm) | V(litros) | € |
|-------|-------|---------------|-------|-------|--------------|-------|-----------|---|
| 10421 | 400 | 415 | 265 | 350 | 365 | 210 | 27 | |

Contenedor isotérmico ALLROUND 60/40
Thermobox ALLROUND 60/40
Conteneur isotherme ALLROUND 60/40
Contentitore isotermico ALLROUND 60/40
Thermobox ALLROUND 60/40



| REF. | W(mm) | OUTSIDE L(mm) | H(mm) | W(mm) | INSIDE L(mm) | H(mm) | V(litros) | € |
|-------|-------|---------------|-------|-------|--------------|-------|-----------|---|
| 10418 | 485 | 660 | 260 | 425 | 625 | 200 | 53 | |
| 10419 | 485 | 685 | 360 | 425 | 625 | 300 | 80 | |



- Base llana y robusta de 350 x 350 mm sin bordes.
Sturdy, flat base 350 x 350 mm without edges.
- Cierre seguro.
Secure locking.
- Superficie antideslizante.
Non-slip surface.

- Apilable con otros contenedores.
Stackable with other containers.
- Sistema de bloqueo en la base.
Locking system at the base.



Cake Box
 Cake Box
 Boîte À Gâteau
 Scatola Per Torta
 Kuchenvitrine

| REF. | OUTSIDE | | | INSIDE | | | V (litros) | € |
|-------|---------|--------|--------|--------|--------|--------|------------|---|
| | W (mm) | L (mm) | H (mm) | W (mm) | L (mm) | H (mm) | | |
| 11766 | 400 | 415 | 280 | 350 | 350 | 175 | 21 | |



Extender Cake Box
 Extender Cake Box
 Extension Boîte À Gâteau Noir
 Estensore Per Scatola Torta
 Erweiterung Kuchenvitrine

| REF. | OUTSIDE | | | INSIDE | | | V (litros) | € |
|-------|---------|--------|--------|--------|--------|--------|------------|---|
| | W (mm) | L (mm) | H (mm) | W (mm) | L (mm) | H (mm) | | |
| 11767 | 410 | 410 | 135 | 350 | 350 | 120 | | |



SALA

DINING ROOM



354 VAJILLA / TABLEWARE

- 354 PLAISIR
- 360 DIM SUM
- 362 PEANA
- 364 AMBAR

368 PRESENTACIÓN / PRESENTATION

- 368 BAUHAUS
- 374 TABLAS PRESENTACIÓN

376 MINIATURAS / MINIATURES

- 376 INOX Y COBRE
- 378 INOX
- 380 FREIDORAS
- 381 PAPEL ANTIGRASA
- 382 HIERRO FUNDIDO
- 384 HIERRO ESMALTADO
- 388 MADERA HAYA
- 390 VAPORERAS

392 SERVICIO MESA / TABLE TOP

- 392 CHAMPAGNERAS
- 396 PANERAS
- 400 VINAGRERAS
- 402 ACCESORIOS

Plaisir



Plaisir
Vajilla / Tableware



354

La colección PLAISIR está compuesta de platos de porcelana perfectos para servir pequeñas porciones de alimentos, lo que permite una presentación elegante y cuidada de las elaboraciones. Su belleza realza la apariencia de los alimentos, convirtiendo una simple porción de comida en una experiencia culinaria especial.

PLAISIR puede ser utilizado para crear composiciones visuales atractivas en la mesa, combinando diferentes colores y diseños para lograr una estética única. Además, suelen ser parte integral de la vajilla de alta gama, aportando un toque de lujo y sofisticación a cualquier evento o comida.

The PLAISIR collection is composed of porcelain plates that are perfect for serving small portions of food, allowing for an elegant and carefully prepared presentation of food. Its beauty enhances the appearance of the food, turning a simple portion of food into a special culinary experience.

PLAISIR can be used to create attractive visual compositions on the table, combining different colours and patterns to achieve a unique aesthetic. In addition, they are often an integral part of high-end tableware, bringing a touch of luxury and sophistication to any event or meal.



355

PLAISIR
Collection.





PLAISIR 1.1

| REF. | COLOR | L(mm) | W(mm) | H(mm) | € | UE / MOQ |
|-------|--------|-------|-------|-------|---|------------|
| 10668 | NEGRO | 101 | 82 | 42 | | 1-4-72 / 4 |
| 10879 | BLANCO | 101 | 82 | 42 | | 1-4-72 / 4 |



PLAISIR 1

| REF. | COLOR | L(mm) | W(mm) | H(mm) | € | UE / MOQ |
|-------|--------|-------|-------|-------|---|------------|
| 10669 | NEGRO | 81 | 70 | 34 | | 1-4-72 / 4 |
| 10880 | BLANCO | 81 | 70 | 34 | | 1-4-72 / 4 |



PLAISIR 2

| REF. | COLOR | L(mm) | W(mm) | H(mm) | € | UE / MOQ |
|-------|--------|-------|-------|-------|---|------------|
| 10670 | NEGRO | 124 | 93 | 35 | | 1-4-72 / 4 |
| 10881 | BLANCO | 124 | 93 | 35 | | 1-4-72 / 4 |



PLAISIR 3

| REF. | COLOR | L(mm) | W(mm) | H(mm) | € | UE / MOQ |
|-------|--------|-------|-------|-------|---|------------|
| 10671 | NEGRO | 134 | 55 | 21 | | 1-4-72 / 4 |
| 10882 | BLANCO | 134 | 55 | 21 | | 1-4-72 / 4 |



PLAISIR 4

| REF. | COLOR | L _(mm) | W _(mm) | H _(mm) | € | UE / MOQ |
|-------|--------|-------------------|-------------------|-------------------|---|------------|
| 10672 | NEGRO | 116 | 71 | 31 | | 1-4-72 / 4 |
| 10883 | BLANCO | 116 | 71 | 31 | | 1-4-72 / 4 |



PLAISIR 5

| REF. | COLOR | L _(mm) | W _(mm) | H _(mm) | € | UE / MOQ |
|-------|--------|-------------------|-------------------|-------------------|---|------------|
| 10673 | NEGRO | 164 | 118 | 43 | | 1-4-72 / 4 |
| 10884 | BLANCO | 164 | 118 | 43 | | 1-4-72 / 4 |

PLAISIR 6



| REF. | COLOR | L _(mm) | W _(mm) | H _(mm) | € | UE / MOQ |
|-------|--------|-------------------|-------------------|-------------------|---|------------|
| 10674 | NEGRO | 129 | 83 | 39 | | 1-4-72 / 4 |
| 10885 | BLANCO | 129 | 83 | 39 | | 1-4-72 / 4 |



PLAISIR 4 XL

| REF. | COLOR | L _(mm) | W _(mm) | H _(mm) | € | UE / MOQ |
|-------|--------|-------------------|-------------------|-------------------|---|------------|
| 10958 | NEGRO | 240 | 145 | 65 | | 1-4-24 / 4 |
| 10960 | BLANCO | 240 | 145 | 65 | | 1-4-24 / 4 |



PLAISIR 7

| REF. | COLOR | L _(mm) | W _(mm) | H _(mm) | € | UE / MOQ |
|-------|--------|-------------------|-------------------|-------------------|---|------------|
| 10675 | NEGRO | 125 | 114 | 26 | | 1-4-72 / 4 |
| 10886 | BLANCO | 125 | 114 | 26 | | 1-4-72 / 4 |



PLAISIR 5 XL

| REF. | COLOR | L _(mm) | W _(mm) | H _(mm) | € | UE / MOQ |
|-------|--------|-------------------|-------------------|-------------------|---|------------|
| 10959 | NEGRO | 247 | 230 | 30 | | 1-4-32 / 4 |
| 10961 | BLANCO | 247 | 230 | 30 | | 1-4-32 / 4 |

PLAISIR 8



| REF. | COLOR | L _(mm) | W _(mm) | H _(mm) | € | UE / MOQ |
|-------|--------|-------------------|-------------------|-------------------|---|------------|
| 10676 | NEGRO | 124 | 80 | 33 | | 1-4-72 / 4 |
| 10887 | BLANCO | 124 | 80 | 33 | | 1-4-72 / 4 |



Dim Sum S

| REF. | Ø(mm) | € | UE / MOQ |
|-------|-------|---|----------------|
| 11588 | 128 | | 1-1-18-0-0 - 1 |



Dim Sum L

| REF. | Ø(mm) | € | UE / MOQ |
|-------|-------|---|---------------|
| 11590 | 186 | | 1-1-2-0-0 / 1 |



Peana blanca

Base white
Base blanc
Base bianca
Basis weiss

| REF. | Ø(mm) | H(mm) | € | UE / MOQ |
|-------|-------|-------|---|----------------|
| 11591 | 155 | 84 | | 1-3-24-0-0 / 3 |



Peana negra

Base black
Base noir
Base nera
Base schwarz

| REF. | Ø(mm) | H(mm) | € | UE / MOQ |
|-------|-------|-------|---|----------------|
| 11592 | 155 | 84 | | 1-3-24-0-0 / 3 |



Peana oval blanca

Base oval white
Base ovale blanc
Base ovale bianca
Basis ovale weiss

| REF. | L(mm) | W(mm) | H(mm) | € | UE / MOQ |
|-------|-------|-------|-------|---|---------------|
| 11593 | 309 | 168 | 88 | | 1-3-9-0-0 / 3 |





Conoce UTSET en la página: 504
More about UTSET in page: 504



Bol cristal
Glass bowl
Bol en verre
Ciotola in vetro
Kristallkugel



| REF. | Ø(mm) | H(mm) | € | UE / MOQ |
|-------|-------|-------|---|----------------|
| 10788 | 190 | 45 | | 0-4-16-0-0 / 4 |

Base Cristal L
Glass Dish Amber L
Assiette En Verre L
Piatto In Vetro L
Glasteller L



| REF. | L(mm) | W(mm) | € | UE / MOQ |
|-------|-------|-------|---|----------------|
| 10792 | 270 | 170 | | 0-4-24-0-0 / 4 |

Base Cristal S
Glass Dish Amber S
Assiette En Verre S
Piatto In Vetro S
Glasteller S



| REF. | L(mm) | W(mm) | € | UE / MOQ |
|-------|-------|-------|---|----------------|
| 10794 | 120 | 120 | | 0-4-96-0-0 / 4 |

NEW

Soporte Snacks Cristal Cuadrado
Glass Square Snack Stand
Support En-Cas En Verre
Supporto Snacks In Vetro
Basso Snack-Theke Glas



| REF. | SIZE | L(mm) | W(mm) | H(mm) | € | UE / MOQ |
|-------|------|-------|-------|-------|---|----------------|
| 11798 | BAJO | 120 | 105 | 30 | | 0-4-32-0-0 / 4 |
| 11799 | ALTO | 115 | 115 | 50 | | 0-4-32-0-0 / 4 |

Bol cristal
Glass bowl
Bol en verre
Ciotola in vetro
Kristallkugel



| REF. | Ø(mm) | H(mm) | € | UE / MOQ |
|-------|-------|-------|---|----------------|
| 10789 | 150 | 40 | | 0-4-48-0-0 / 4 |

Base Cristal M
Glass Dish Amber M
Assiette En Verre M
Piatto In Vetro M
Glasteller M



| REF. | L(mm) | W(mm) | € | UE / MOQ |
|-------|-------|-------|---|----------------|
| 10793 | 120 | 240 | | 0-4-48-0-0 / 4 |

Soporte snacks mini
Glass Mini Snack Stand
Support En-Cas En Verre Mini
Supporto Snacks In Vetro Mini
Snack-Theke Mini



| REF. | L(mm) | W(mm) | € | UE / MOQ |
|-------|-------|-------|---|----------------|
| 11797 | 150 | 50 | | 0-4-72-0-0 / 4 |

Soporte tacos cristal doble
Double glass support
Support double verre
Supporto vetro doppio
Doppelte glshalterung



| REF. | L(mm) | H(mm) | W(mm) | € | UE / MOQ |
|-------|-------|-------|-------|---|--------------------|
| 10791 | 180 | 50 | 60 | | 0-4-24-192-384 / 4 |

NEW

Soporte Snacks Cristal rectangular
Glass Oblong Snack Stand
Support En-Cas En Verre Rectangulaire
Supporto Snacks In Vetro rettangolare
Snack-Theke Glas Rechteckig



| REF. | SIZE | L(mm) | W(mm) | H(mm) | € | UE / MOQ |
|-------|------|-------|-------|-------|---|----------------|
| 11800 | BAJO | 210 | 60 | 28 | | 0-4-36-0-0 / 4 |
| 11801 | ALTO | 210 | 90 | 45 | | 0-4-36-0-0 / 4 |

NEW

Plato Tiro Cristal Redondo
Glass Plate Round
Assiette Resto En Verre Ronde
Piatto Tiro In Vetro Rotondo
Runder Glasteller Tiro



| REF. | SIZE | Ø(mm) | H(mm) | € | UE / MOQ |
|-------|------|-------|-------|---|----------------|
| 11802 | S | 140 | 13 | | 0-4-96-0-0 / 4 |
| 11803 | M | 180 | 13 | | 0-4-40-0-0 / 4 |
| 11804 | L | 220 | 13 | | 0-4-40-0-0 / 4 |

NEW

Soporte Cristal Redondo 3 Patas
Glass Stand Round 3 Feet
Support En Verre Rond 3 Pieds
Supporto In Vetro Rdo 3 Gambe
Runder Glasaufsteller Mit 3 Füßen



| REF. | Ø(mm) | H(mm) | € | UE / MOQ |
|-------|-------|-------|---|----------------|
| 11805 | 140 | 13 | | 0-4-96-0-0 / 4 |

NEW

Teja Cristal Ambar
Patterned Glass Amber Roof Tile
Assiette Tuile En Verre Ambre
Tegola Di Vetro Ambar
Glasziegel Bernstein



| REF. | L(mm) | W(mm) | € | UE / MOQ |
|-------|-------|-------|---|----------------|
| 11943 | 300 | 90 | | 0-4-48-0-0 / 4 |

NEW

Zigzac 2 Tacos
Zigzag 2 Tacos
Zigzag 2 Tacos
Zigzag 2 Tacos
Zigzag 2 Tacos



| REF. | L(mm) | W(mm) | H(mm) | € | UE / MOQ |
|-------|-------|-------|-------|---|----------------|
| 11806 | 140 | 130 | 16 | | 0-4-48-0-0 / 4 |

NEW

Zigzac 4 Tacos
Zigzag 4 Tacos
Zigzag 4 Tacos
Zigzag 4 Tacos
Zigzag 4 Tacos



| REF. | L(mm) | W(mm) | H(mm) | € | UE / MOQ |
|-------|-------|-------|-------|---|----------------|
| 11807 | 140 | 250 | 18 | | 0-4-32-0-0 / 4 |



Bauhaus



Bauhaus
Presentación / Presentation



Set de maderas de presentación, concebidas tanto para un uso doméstico como para la cocina de autor, ya que las medidas están adaptadas a las últimas pautas de Gastronorm.

Con una estética atrayente por su simplicidad, Bauhaus es una propuesta versátil que enriquece rituales alrededor de una mesa como un aperitivo, momento de los postres o simplemente un brunch en casa con amigos.

La madera es un material natural que aporta un toque de calidez y sofisticación a cualquier mesa.



A set of presentation boards, conceived from a domestic use to the signature cuisine, as the measurements are adapted to the latest Gastronorm guidelines.

With an appealing aesthetic for its simplicity, Bauhaus is a versatile proposal that enriches rituals around the table such as an aperitif, the dessert moment or simply a brunch at home with friends.

Wood is a natural material that adds a touch of warmth and sophistication to any table.





Las tablas vienen preparadas con una muesca para encajar y atornillar los aros.

The tables come prepared with a notch to fit and screw the rings.



Tabla presentación

Wooden table for table service
Table en bois pour service de table
Tavolo in legno per servizio a tavola
Holztisch für tischservice

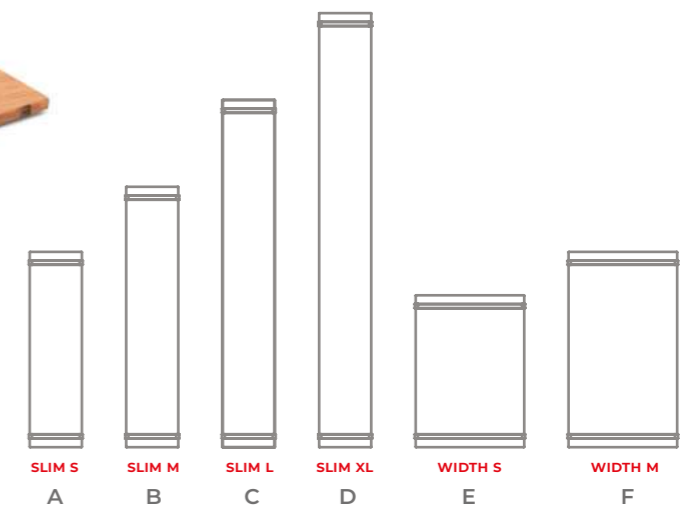

| REF. | MODELO | L(mm) | W(mm) | H(mm) | AROS COMPATIBLES / COMPATIBLE RINGS | € | UE / MOQ |
|--------|---------|-------|-------|-------|-------------------------------------|---|------------|
| A 9985 | SLIM S | 120 | 450 | 15 | 10648, 10649 | | 1-0-24 / 1 |
| B 9986 | SLIM M | 120 | 600 | 15 | 10648, 10649 | | 1-0-20 / 1 |
| C 9987 | SLIM L | 120 | 800 | 15 | 10648, 10649 | | 1-0-12 / 1 |
| D 9988 | SLIM XL | 120 | 1000 | 15 | 10648, 10649 | | 1-0-10 / 1 |
| E 9989 | WIDTH S | 250 | 350 | 15 | 10719, 10720 | | 1-0-16 / 1 |
| F 9990 | WIDTH M | 250 | 450 | 15 | 10719, 10720 | | 1-0-12 / 1 |



Pack 2 Aros

Pack 2 st/st ring
Pack 2 anneau en acier
Pack 2 anello in acciaio
Pack 2 stahling

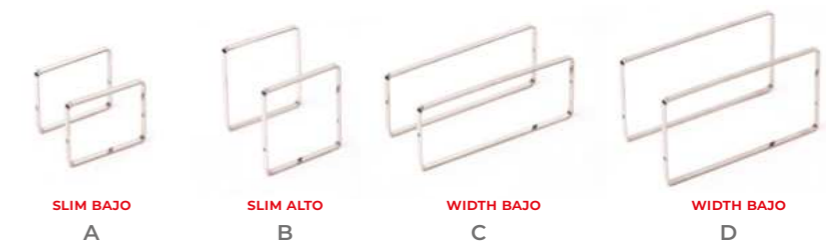

| REF. | L(mm) | H(mm) | COMPATIBLE CON TABLA / COMPATIBLE WITH TABLE | € | UE / MOQ |
|---------|-------|-------|--|---|-------------|
| A 10648 | 120 | 90 | SLIM | | 1-15-60 / 2 |
| B 10649 | 120 | 120 | SLIM | | 1-15-60 / 2 |
| C 10719 | 250 | 90 | WIDTH | | 1-15-60 / 2 |
| D 10720 | 250 | 120 | WIDTH | | 1-15-60 / 2 |



Sistema modular a 2 alturas. Madera y aros se venden por separado.

Modular system at 2 heights. Wood and rings are sold by separately.

Aro de acero inoxidable.

Stainless steel ring.



Tablas de madera de roble.

Oak wood presentation table.

Escoge la medida de la tabla de madera y la altura de los aros para personalizar tu tabla de presentación.

Choose the size of the wooden board and the height of the hoops to customize your presentation board.



ESCOGE TU KIT / CHOOSE YOUR KIT



| REF. KIT | REF. TABLA + REF. ARO | = | DESCRIPCIÓN | € | UE/MOQ |
|----------|-----------------------|---|--------------------------------|---|-------------|
| 11170 | 9985 10648 | | TABLA SLIM S + ARO SLIM BAJO | | 1-0-0-0-0/1 |
| 11171 | 9985 10649 | | TABLA SLIM S + ARO SLIM ALTO | | 1-0-0-0-0/1 |
| 11172 | 9986 10648 | | TABLA SLIM M + ARO SLIM BAJO | | 1-0-0-0-0/1 |
| 11173 | 9986 10649 | | TABLA SLIM M + ARO SLIM ALTO | | 1-0-0-0-0/1 |
| 11174 | 9987 10648 | | TABLA SLIM L + ARO SLIM BAJO | | 1-0-0-0-0/1 |
| 11175 | 9987 10649 | | TABLA SLIM L + ARO SLIM ALTO | | 1-0-0-0-0/1 |
| 11176 | 9988 10648 | | TABLA SLIM XL + ARO SLIM BAJO | | 1-0-0-0-0/1 |
| 11177 | 9988 10649 | | TABLA SLIM XL + ARO SLIM ALTO | | 1-0-0-0-0/1 |
| 11178 | 9989 10719 | | TABLA WIDTH S + ARO WIDTH BAJO | | 1-0-0-0-0/1 |
| 11179 | 9989 10720 | | TABLA WIDTH S + ARO WIDTH ALTO | | 1-0-0-0-0/1 |
| 11180 | 9990 10719 | | TABLA WIDTH M + ARO WIDTH BAJO | | 1-0-0-0-0/1 |
| 11181 | 9990 10720 | | TABLA WIDTH M + ARO WIDTH ALTO | | 1-0-0-0-0/1 |



Tabla madera
Wooden table
Table en bois
Tavolo in legno
Eichenholztisch



| REF. | L(mm) | W(mm) | H(mm) | € | UE / MOQ |
|-------|-------|-------|-------|---|---------------|
| 11016 | 330 | 230 | 20 | | 1-0-4-0-0 / 4 |
| 11017 | 390 | 280 | 20 | | 1-0-4-0-0 / 4 |

* En caso de poner comida directamente en la bandeja, recomendamos el uso de papel anti-grasa.

If food is placed directly on the tray, we recommend the use of greaseproof paper.



Bandeja madera bambú
Bamboo tray
Plateau en bambou
Vassoio in bambù
Bambus-tablett



| REF. | L(mm) | W(mm) | H(mm) | € | UE / MOQ |
|-------|-------|-------|-------|---|---------------|
| 10998 | 200 | 100 | 30 | | 1-0-4-0-0 / 4 |
| 10999 | 300 | 200 | 30 | | 1-0-4-0-0 / 4 |
| 11000 | 400 | 300 | 30 | | 1-0-4-0-0 / 4 |
| 11001 | 530 | 320 | 45 | | 1-0-4-0-0 / 4 |



Pizarra + Base acacia
Slate board +Acacia base
Ardoise + Socle acacia
Ardesia + Base in acacia
Schiefer + Basis aus akazie

* Acabado brillo / Gloss finish

| REF. | L(mm) | W(mm) | H(mm) | € | UE / MOQ |
|-------|-------|-------|-------|---|---------------|
| 11574 | 550 | 345 | 20 | | 1-0-0-0-0 / 1 |
| 11575 | 340 | 285 | 15 | | 1-0-0-0-0 / 1 |
| 11576 | 340 | 195 | 15 | | 1-0-0-0-0 / 1 |
| 11577 | 320 | 320 | 15 | | 1-0-0-0-0 / 1 |



Pizarra
Slate board
Ardoise
Ardesia
Schiefer



| REF. | FORMATO | L(mm) | W(mm) | H(mm) | € | UE / MOQ | COMPATIBLE CON / COMPATIBLE WITH: |
|-------|---------|-------|-------|-------|---|----------------|--------------------------------------|
| 11002 | 1/1 | 530 | 325 | 5 | | 1-0-6-0-0 / 4 | 11005, 11006, 11007, 11573 |
| 11003 | 1/2 | 325 | 265 | 5 | | 1-0-10-0-0 / 4 | |
| 11004 | 1/3 | 325 | 175 | 5 | | 1-0-15-0-0 / 4 | |
| 11572 | | 300 | 300 | 5 | | 1-0-0-0-0 / 1 | |

Base madera para pizarra
Base for slate tray
Socle pour plateau ardoise
Base per vassoio in ardesia
Basis für schieferfach



| REF. | L(mm) | W(mm) | H(mm) | € | UE / MOQ | COMPATIBLE CON / COMPATIBLE WITH: |
|-------|-------|-------|-------|---|----------------|--------------------------------------|
| 11005 | 550 | 345 | 20 | | 1-0-10-0-0 / 4 | 11002, 11003, 11004, 11572 |
| 11006 | 345 | 285 | 15 | | 1-0-20-0-0 / 4 | |
| 11007 | 345 | 195 | 15 | | 1-0-40-0-0 / 4 | |
| 11573 | 320 | 320 | 15 | | 1-0-0-0-0 / 1 | |

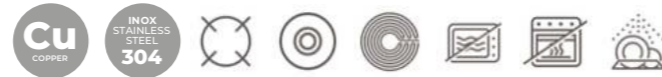

Capa interior acero inoxidable.
Total seguridad para el contacto alimentario.

Stainless steel interior.
Food contact total security.

Asas de bronce.

Brass handles.



CONDUCTIVIDAD TÉRMICA

Capa exterior cobre.
Facilita la cocción gracias a que este material ayuda a crear una distribución uniforme del calor por toda la superficie.

Copper exterior.
Facilitates the cooking because this material helps to create a uniform distribution of heat on all the surface.

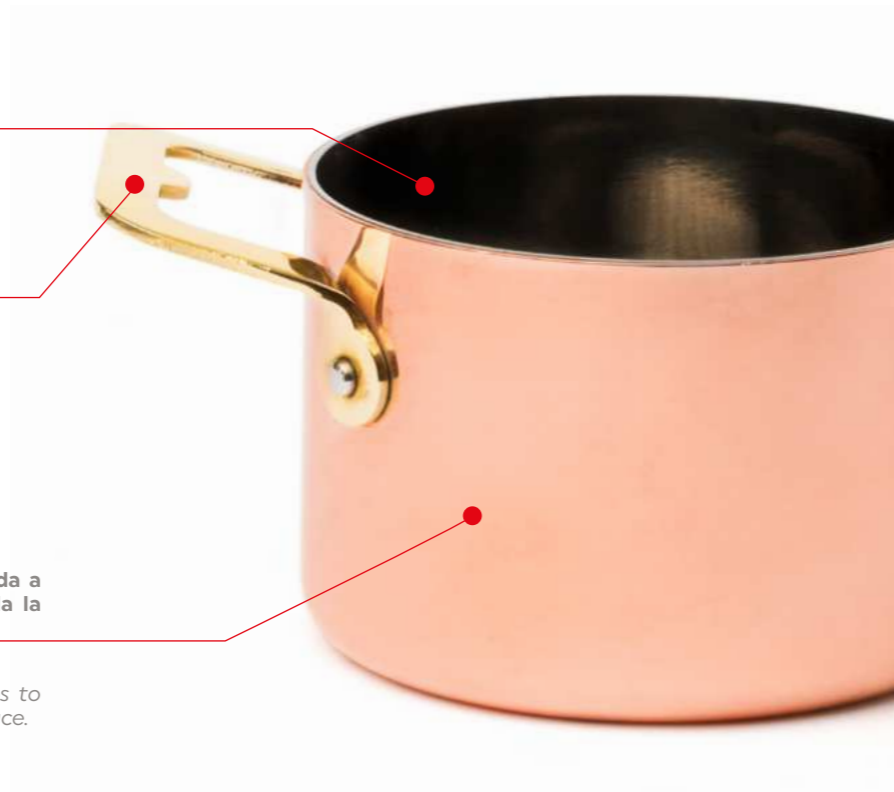

Mini sartén doble pared

Mini fry pan dual body
Mini poêle double paroi
Mini padella doppia parete
Copper mini pffanne dualer körper



| REF. | Ø(mm) | H(mm) | € | UE / MOQ |
|------|-------|-------|---|--------------------|
| 7493 | 120 | 35 | | 1-6-48-192-384 / 1 |

Mini olla doble pared

Mini casserole dual body
Mini casserole double paroi
Mini pentola doppia parete
Mini kasserole dualer körper



| REF. | Ø(mm) | H(mm) | € | UE / MOQ |
|------|-------|-------|---|--------------------|
| 7495 | 90 | 60 | | 1-6-48-192-384 / 1 |

Mini cazo doble pared

Mini saucepan dual body
Mini casserole double paroi
Mini casseruola doppia parete
Mini sauteuse dualer körper



| REF. | Ø(mm) | H(mm) | € | UE / MOQ |
|------|-------|-------|---|--------------------|
| 7491 | 70 | 50 | | 1-6-48-288-864 / 1 |

Mini paella doble pared

Mini paella dual body
Mini paella double paroi
Mini paella doppia parete
Mini paella pffanne dualer körper



| REF. | Ø(mm) | H(mm) | € | UE / MOQ |
|------|-------|-------|---|--------------------|
| 7497 | 120 | 25 | | 1-6-48-288-576 / 1 |



Mini sartén inox

Mini fry pan inox
Mini poêle inox
Mini padella inox
Mini pffanne edelstah



| REF. | Ø(mm) | H(mm) | € | UE / MOQ |
|------|-------|-------|---|--------------------|
| 7492 | 100 | 30 | | 1-6-48-192-384 / 1 |

Mini olla inox

Mini casserole inox
Mini casserole inox
Mini pentola inox
Mini kasserole edelstahl



| REF. | Ø(mm) | H(mm) | € | UE / MOQ |
|------|-------|-------|---|--------------------|
| 7494 | 90 | 60 | | 1-6-48-192-384 / 1 |

Mini cazo inox

Mini saucepan inox
Mini casserole inox
Mini casseruola inox
Mini sauteuse edelstahl



| REF. | Ø(mm) | H(mm) | € | UE / MOQ |
|------|-------|-------|---|--------------------|
| 7490 | 70 | 50 | | 1-6-48-288-864 / 1 |

Mini wok inox

Mini wok inox
Mini wok inox
Mini wok inox
Mini wok edelstahl



| REF. | Ø(mm) | H(mm) | € | UE / MOQ |
|------|-------|-------|---|--------------------|
| 7496 | 110 | 50 | | 1-6-48-192-384 / 1 |





Cubo snack
Snack bucket
Bol à aperitif
Vaschetta snack
Snack eimer



| REF. | Ø(mm) | H(mm) | ml | € | UE / MOQ |
|-------------|-------|-------|-----|---|--------------------|
| 7104 | 125 | 130 | 800 | | 1-6-24-72-144 / 6 |
| 7103 | 85 | 90 | 320 | | 1-6-24-192-576 / 6 |
| 7102 | 70 | 75 | 200 | | 1-6-24-288-864 / 6 |

Mini cubo inox
Inox mini bin
Mini seau inox
Mini bidone inox
Mini behälter edelstahl



| REF. | Ø(mm) | H(mm) | ml | € | UE / MOQ |
|-------------|-------|-------|------|---|---------------------|
| 7500 | 150 | 140 | 1500 | | 1-6-48-144-432 / 6 |
| 7499 | 130 | 120 | 850 | | 1-6-48-192-768 / 6 |
| 7498 | 90 | 90 | 350 | | 1-6-48-576-1152 / 6 |

Lechera snack
Snack milk pot
Pot à lait snack
Latteria snack
Snack molkerei



| REF. | Ø(mm) | H(mm) | ml | € | UE / MOQ |
|-------------|-------|-------|----|---|---------------------|
| 7105 | 45 | 50 | 45 | | 1-6-24-384-1536 / 6 |
| 7106 | 75 | 100 | 80 | | 1-6-24-192-384 / 6 |

Rustidera snack
Snack lasagna pan
Plat à rôtir snack
Rostiera snack
Snack lasagneform



| REF. | Ø(mm) | H(mm) | ml | € | UE / MOQ |
|-------------|-------|-------|-----|---|--------------------|
| 7107 | 95 | 145 | 400 | | 1-6-24-168-336 / 6 |

INOX
STAINLESS
STEEL
430

Cesto cuadrado
Square basket
Panier à frites carré
Cestino quadrato da frittura
Quadratischer korb

| REF. | COLOR | W _(mm) | L _(mm) | H _(mm) | € | UE / MOQ |
|------|--------|-------------------|-------------------|-------------------|---|----------------------|
| 7482 | SILVER | 100 | 90 | 70 | | 1-12-144-576-576 / 6 |
| 7483 | GOLD | 100 | 90 | 70 | | 1-12-144-576-576 / 6 |
| 7484 | BLACK | 100 | 90 | 70 | | 1-12-144-576-576 / 6 |



Cesto cuadrado
Square basket
Panier à frites carré
Cestino quadrato da frittura
Quadratischer korb

| REF. | W _(mm) | L _(mm) | H _(mm) | € | UE / MOQ |
|------|-------------------|-------------------|-------------------|---|----------------------|
| 7485 | 130 | 110 | 90 | | 1-12-144-576-576 / 6 |



Mini freidora cuadrada
Mini square fryer
Mini friteuse
Mini friggitore
Quadratischer mini fittierkorb

| REF. | W _(mm) | L _(mm) | H _(mm) | € | UE / MOQ |
|------|-------------------|-------------------|-------------------|---|---------------------|
| 7488 | 110 | 110 | 50 | | 1-12-48-192-384 / 6 |



Cesto redondo
Round basket
Panier à frites rond
Cestino rotondo da frittura
Runder korb

| REF. | Ø _(mm) | H _(mm) | € | UE / MOQ |
|------|-------------------|-------------------|---|----------------------|
| 7480 | 80 | 85 | | 1-12-144-576-576 / 6 |
| 7481 | 90 | 125 | | 1-12-144-576-576 / 6 |



Cono chips
Cone for chips
Cornet de frites
Cono per patatine fritte
Kegel für pommes

| REF. | Ø _(mm) | H _(mm) | € | UE / MOQ |
|------|-------------------|-------------------|---|----------------------|
| 7487 | 110 | 230 | | 1-12-144-576-576 / 6 |



Cesto rectangular
Rectangular basket
Panier à frites rectangulaire
Cestino rettangolare per frittura
Rechteckiger korb

| REF. | W _(mm) | L _(mm) | H _(mm) | € | UE / MOQ |
|------|-------------------|-------------------|-------------------|---|--------------------|
| 7486 | 210 | 100 | 40 | | 1-6-72-288-288 / 6 |



Cesto con asas
Basket with handles
Panier à frites avec des poignées
Cestino da frittura maniglie
Korb mit griffen

| REF. | W _(mm) | L _(mm) | H _(mm) | € | UE / MOQ |
|------|-------------------|-------------------|-------------------|---|----------------------|
| 7489 | 110 | 85 | 55 | | 1-12-72-720-1440 / 6 |



PACKAGING
HANG TAG



Envoltorio antigrasas blanco
White greaseproof wrapping
Emballage anti-graisse blanc
Foglio carta antigrasso bianco
Pergamentpapier weiss

| REF. | W _(mm) | L _(mm) | € | UE / MOQ |
|-----------|-------------------|-------------------|---|---------------------|
| 7678 | 200 | 250 | | 1k-8k-48k-336k / 1k |
| 7676 | 280 | 340 | | 1k-4k-24k-168k / 1k |
| NEW 11991 | 200 | 120 | | 1-1k-8k / 1k |
| NEW 11992 | 300 | 20 | | 1-1k-4k / 1k |



Envoltorio antigrasas natural
Natural greaseproof wrapping
Emballage anti-graisse naturel
Foglio carta antigrasso naturale
Pergamentpapier natur

| REF. | W _(mm) | L _(mm) | € | UE / MOQ |
|------|-------------------|-------------------|---|---------------------|
| 7677 | 280 | 340 | | 1k-4k-24k-168k / 1k |



Envoltorio antigrasas times natural
Times natural greaseproof wrapping
Emballage anti-graisse times naturel
Foglio carta antigrasso times naturale
Pergamentpapier weiss times naturel

| REF. | W _(mm) | L _(mm) | € | UE / MOQ |
|------|-------------------|-------------------|---|---------------------|
| 8809 | 280 | 340 | | 1k-4k-24k-168k / 1k |



Envoltorio antigrasas negro
Black greaseproof wrapping
Emballage anti-graisse noir
Foglio carta antigrasso nero
Pergamentpapier schwarz

| REF. | W _(mm) | L _(mm) | € | UE / MOQ |
|------|-------------------|-------------------|---|---------------------|
| 7674 | 280 | 340 | | 1k-4k-24k-168k / 1k |



Envoltorio antigrasas rojo
Red greaseproof wrapping
Emballage anti-graisse rouge
Foglio carta antigrasso rosso
Pergamentpapier rot

| REF. | W _(mm) | L _(mm) | € | UE / MOQ |
|------|-------------------|-------------------|---|---------------------|
| 7675 | 280 | 340 | | 1k-4k-24k-168k / 1k |



Sala / Dining room
TRADICIÓN COLLECTION



Mini caldero 3 patas
Mini cooking pot 3 feet
Mini cocotte en fonte 3 pieds
Mini casseruola di ghisa 3 piedi
Gusseisen mini kasserole m. 3 füßen



| REF. | Ø(mm) | H(mm) | ml | € | UE / MOQ |
|------|-------|-------|----|---|-------------------|
| 7510 | 110 | 95 | 35 | | 1-6-12-96-288 / 1 |



Mini sartén cuadrada
Mini square pan
Mini poêle carrée en fonte
Mini padella quadrata di ghisa
Gusseisen quadratische mini pfanne



| REF. | W(mm) | L(mm) | H(mm) | € | UE / MOQ |
|------|-------|-------|-------|---|-------------------|
| 7503 | 140 | 140 | 30 | | 1-6-12-96-384 / 1 |



Mini olla oval
Mini oval casserole
Mini cocotte ovale en fonte
Mini casseruola ovale di ghisa
Gusseisen ovale mini kasserole



| REF. | W(mm) | L(mm) | H(mm) | ml | € | UE / MOQ |
|------|-------|-------|-------|-----|---|-------------------|
| 7506 | 95 | 125 | 55 | 270 | | 1-6-12-48-144 / 1 |



Mini sartén redonda 2 asas
Mini round pan 2 handles
Mini poêle ronde en fonte 2 poignets
Mini padella rotonda di ghisa 2 manici
Gusseisen runde mini pfanne m. 2 griffen



| REF. | Ø(mm) | H(mm) | € | UE / MOQ |
|------|-------|-------|---|--------------------|
| 7508 | 122 | 30 | | 1-6-24-144-576 / 1 |

Hierro fundido / Cast Iron



Mini sartén
Mini pan
Mini poêle en fonte
Mini padella di ghisa
Gusseisen mini pfanne



| REF. | Ø(mm) | H(mm) | € | UE / MOQ |
|------|-------|-------|---|--------------------|
| 7502 | 90 | 25 | | 1-6-24-192-768 / 1 |



Mini sartén
Mini pan
Mini poêle en fonte
Mini padella di ghisa
Gusseisen mini pfanne



| REF. | Ø(mm) | H(mm) | € | UE / MOQ |
|------|-------|-------|---|--------------------|
| 7501 | 130 | 15 | | 1-6-24-192-768 / 1 |



Mini sartén oval 2 asas
Mini oval pan 2 handles
Mini poêle ovale en fonte 2 poignets
Mini padella ovale di ghisa 2 manici
Gusseisen ovale mini pfanne m. 2 griffen



| REF. | W(mm) | L(mm) | H(mm) | € | UE / MOQ |
|------|-------|-------|-------|---|-------------------|
| 7507 | 180 | 126 | 35 | | 1-6-24-96-288 / 1 |



Mini sartén redonda 2 asas
Mini round pan 2 handle
Mini poêle ronde en fonte 2 poignets
Mini padella rotonda di ghisa 2 manici
Gusseisen runde mini pfanne m. 2 griffen



| REF. | Ø(mm) | H(mm) | € | UE / MOQ |
|------|-------|-------|---|--------------------|
| 7509 | 145 | 30 | | 1-6-24-144-576 / 1 |

Bases de madera / Wooden board



Servicio mesa / Miniaturas
Table top / Miniatures

- 1** Lavar antes del primer uso.
Wash before first use.
 - 2** Después de cada uso, dejar enfriar y lavar a mano.
After each use, leave to cool and wash by hand.
 - 3** Untar con aceite para una mejor conservación.
Spread with oil for better preservation.
- * **Nuestras piezas de hierro fundido no son antideslizantes.**
Our cast iron griddles are not non-stick items.



Mini olla
Mini casserole
Mini cocotte en fonte
Mini casseruola di ghisa
Gusseisen mini kasserole



| REF. | Ø(mm) | H(mm) | ml | € | UE / MOQ |
|------|-------|-------|----|---|-------------------|
| 7504 | 140 | 110 | 60 | | 1-6-12-48-144 / 1 |



Mini olla
Mini casserole
Mini cocotte en fonte
Mini casseruola di ghisa
Gusseisen mini kasserole



| REF. | Ø(mm) | H(mm) | ml | € | UE / MOQ |
|------|-------|-------|----|---|-------------------|
| 7505 | 110 | 60 | 35 | | 1-6-24-96-288 / 1 |



Soporte madera
Wooden board
Support en bois
Table di legno
Holzplatte



ROUND



OVAL



SQUARE

| REF. | MODEL | W(mm) | L(mm) | € | UE / MOQ |
|------|--------|-------|-------|---|--------------------|
| 7789 | ROUND | 150 | 150 | | 1-6-12-168-504 / 1 |
| 7790 | OVAL | 200 | 140 | | 1-6-12-144-432 / 1 |
| 7791 | SQUARE | 160 | 160 | | 1-6-12-144-432 / 1 |





Hierro esmaltado / Enamelled Iron



Servicio mesa / Miniaturas
 Table top / Miniatures



Cuenco rectangular
 Rectangular pie dish
 Bol rectangulaire
 Ciotola rettangolare
 Eisenschälchen rechteckig

| REF. | W _(mm) | L _(mm) | H _(mm) | € | UE / MOQ |
|------|-------------------|-------------------|-------------------|---|-----------------------|
| 7517 | 145 | 200 | 40 | | 1-12-48-480-1600 / 12 |
| 7516 | 130 | 180 | 35 | | 1-12-96-768-2304 / 12 |
| 7515 | 120 | 160 | 30 | | 1-12-96-864-2592 / 12 |



Cuenco rectangular
 Rectangular pie dish
 Bol rectangulaire
 Ciotola rettangolare
 Eisenschälchen rechteckig

| REF. | W _(mm) | L _(mm) | H _(mm) | € | UE / MOQ |
|------|-------------------|-------------------|-------------------|---|-----------------------|
| 7520 | 145 | 200 | 40 | | 1-12-48-432-1296 / 12 |
| 7519 | 130 | 180 | 35 | | 1-12-96-768-2304 / 12 |
| 7518 | 120 | 160 | 30 | | 1-12-96-864-2592 / 12 |



Plato llano
 Flat plate
 Assiette plate
 Piatto piano
 Flacher teller



Plato hondo
 Deep plate
 Plat creux
 Piatto fondo
 Tiefer teller



Plato postre
 Dessert plate
 Assiette dessert
 Piatto dessert
 Dessertteller

| REF. | SIZE | Ø _(mm) | H _(mm) | € | UE / MOQ |
|-------|--------------|-------------------|-------------------|---|------------------|
| 10909 | PLATO LLANO | 260 | 20 | | 0-12-48-0-0 / 12 |
| 10910 | PLATO HONDO | 220 | 35 | | 0-12-48-0-0 / 12 |
| 10908 | PLATO POSTRE | 200 | 15 | | 0-12-96-0-0 / 12 |

Sala / Dining room
PELTRE COLLECTION

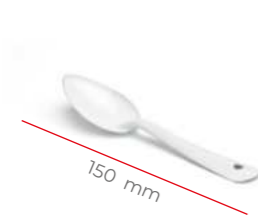

Cuchara de té
Tea spoon
Cuillère à thé
Cucchiaio da tè
Teelöffel

| REF. | SIZE | L(mm) | € | UE / MOQ |
|------|-------------------|-------|---|-------------------------|
| 7511 | CUCHARA DE TÉ | 150 | | 1-12-120-3000-6000 / 12 |
| 7512 | CUCHARA DE MESA | 200 | | 1-12-120-3000-6000 / 12 |
| 7513 | CUCHARA DE SERVIR | 300 | | 1-10-50-1600-3200 / 10 |

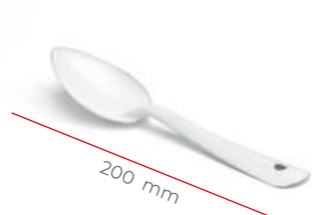

Cuchara de mesa
Table spoon
Cuillère de table
Cucchiaio da tavola
Tafelöffel

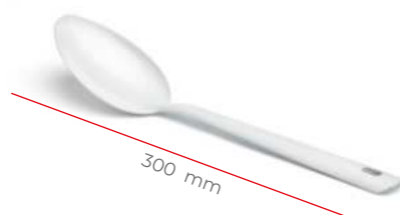

Cuchara de servir
Server spoon
Cuillère servir
Cucchiaio da portata
Servierlöffel

Vaso para dippear
Dip cup
Mini coupe pour tremper
Bicchiere per sugo
Eisen dipschale



| REF. | Ø(mm) | H(mm) | ml | € | UE / MOQ |
|------|-------|-------|-----|---|------------------------|
| 7530 | 70 | 30 | 100 | | 1-12-96-1152-2304 / 12 |
| 7529 | 60 | 40 | 90 | | 1-12-96-1920-3840 / 12 |

Lechera
Creamer
Laitière
Bidone del latte
Eisenkännchen



| REF. | Ø(mm) | H(mm) | ml | € | UE / MOQ |
|------|-------|-------|-----|---|----------------------|
| 7514 | 70 | 65 | 190 | | 1-12-96-384-768 / 12 |

Vaso alto
Taller tumbler
Coupe hauteur
Bicchiere
Emailliertes



| REF. | Ø(mm) | H(mm) | ml | € | UE / MOQ |
|------|-------|-------|-----|---|----------------------|
| 7528 | 80 | 120 | 400 | | 1-12-48-192-384 / 12 |
| 7527 | 80 | 90 | 290 | | 1-12-96-384-768 / 12 |

Taza
Mug
Tasse
Tazza
Eisenbecher



| REF. | Ø(mm) | H(mm) | ml | € | UE / MOQ |
|------|-------|-------|-----|---|-----------------------|
| 7522 | 70 | 70 | 250 | | 1-12-96-384-1152 / 12 |
| 7521 | 60 | 45 | 100 | | 1-12-96-384-1152 / 12 |

Cazuela 2 asas
Casserole 2 handle
Casserole 2 poignées
Casseruola 2 manici
Kasserole mit griff



| REF. | Ø(mm) | H(mm) | ml | € | UE / MOQ |
|------|-------|-------|-----|---|----------------------|
| 7525 | 100 | 50 | 310 | | 1-12-96-384-768 / 12 |

Bol
Bowl
Bol
Ciotola
Eisenschale



| REF. | Ø(mm) | H(mm) | ml | € | UE / MOQ |
|------|-------|-------|-----|---|-----------------------|
| 7526 | 140 | 60 | 510 | | 1-12-48-576-1152 / 12 |

Hierro esmaltado / Enamelled iron



Sartén honda
Deep frying pan
Poêle profonde
Padella
Mini-pfannen



| REF. | Ø(mm) | H(mm) | € | UE / MOQ |
|------|-------|-------|---|-----------------------|
| 7826 | 140 | 38 | | 1-10-60-360-1020 / 10 |
| 7827 | 160 | 43 | | 1-10-50-200-1000 / 10 |
| 7828 | 180 | 48 | | 1-6-36-1008-1008 / 6 |
| 7829 | 200 | 53 | | 1-6-42-924-924 / 6 |

Cazuela 2 asas marrón
Brown casserole 2 handle
Casserole émaillé 2 poignées brown
Casseruola ferro smaltato 2 manici brown
Emaillierte kasserole mit griff brown



| REF. | Ø(mm) | H(mm) | ml | € | UE / MOQ |
|------|-------|-------|-----|---|---------------------|
| 7524 | 100 | 50 | 310 | | 1-12-96-384-768 / 6 |

Servicio mesa / Miniaturas
Table top / Miniatures



Fuente acero esmaltada con asas
Deep enamelled fry pan with handles
Poêle haute avec anses
Padella smaltata con manici
Emaillierte platte mit griffen

| REF. | Ø(mm) | € | UE / MOQ |
|-------|-------|---|------------|
| 10934 | 120 | | 1-6-48 / 6 |
| 10935 | 160 | | 1-6-48 / 6 |
| 10936 | 200 | | 1-6-48 / 6 |

Paellera
Paella pan
Poêle à paella
Padella
Paella-pfannen



| REF. | Ø(mm) | H(mm) | € | UE / MOQ |
|------|-------|-------|---|------------------------|
| 7792 | 100 | 20 | | 1-10-100-300-1000 / 10 |
| 7793 | 120 | 22 | | 1-10-100-400-1000 / 10 |
| 7794 | 150 | 24 | | 1-10-80-320-960 / 10 |
| 7795 | 200 | 26 | | 1-6-36-648-648 / 6 |

Mini cazuela 2 asas marrón
Brown mini casserole 2 handle
Mini casserole émaillé 2 poignées brown
Mini casseruola ferro smaltato 2 manici brown
Emaillierte mini kasserole mit griff brown



| REF. | Ø(mm) | H(mm) | ml | € | UE / MOQ |
|------|-------|-------|-----|---|----------------------|
| 7523 | 100 | 30 | 125 | | 1-12-48-576-1728 / 6 |



Madera de haya de alta calidad.

High quality beech wood.

Acabados con aceites naturales que protegen y alargan la durabilidad de las piezas.

Finishes with natural oils that protect and prolong the pieces durability.

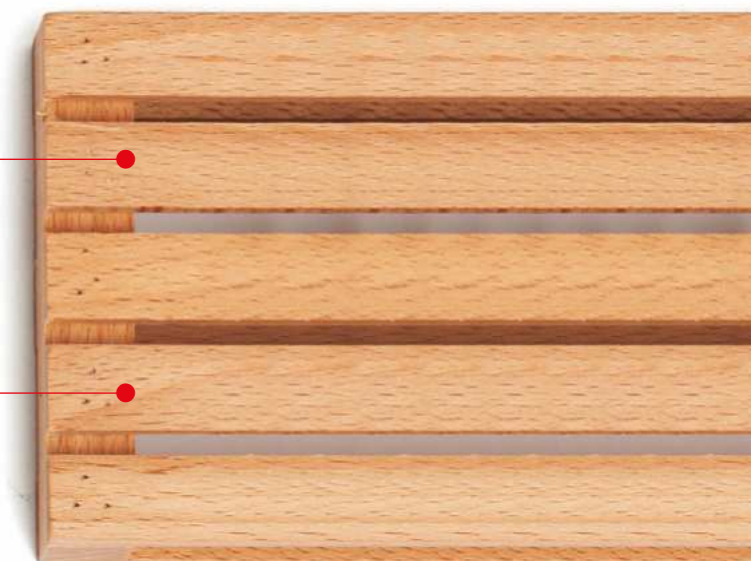

Mini palé
 Mini pallet
 Mini palette
 Mini bancale
 Mini palette



| REF. | L _(mm) | W _(mm) | H _(mm) | € | UE / MOQ |
|------------------|-------------------|-------------------|-------------------|---|--------------------|
| 7548 | 200 | 120 | 35 | | 0-3-36-288-864 / 3 |
| NEW 11965 | 180 | 300 | 35 | | 1-0-20-0-0 / 1 |



Mini caja cuadrada
 Mini square box
 Mini cagette carrée en bois
 Mini cassetta legno quadrata
 Quadratische mini holzbox

| REF. | L _(mm) | W _(mm) | H _(mm) | € | UE / MOQ |
|-------------|-------------------|-------------------|-------------------|---|-------------------|
| 7544 | 170 | 170 | 70 | | 1-0-12-48-144 / 6 |
| 7545 | 210 | 210 | 70 | | 1-0-12-72-216 / 6 |



Mini caja rectangular
 Mini rectangular wooden box
 Mini cagette rectangulaire
 Mini cassetta legno rettangolare
 Rechteckige mini holzbox

| REF. | L _(mm) | W _(mm) | H _(mm) | € | UE / MOQ |
|-------------|-------------------|-------------------|-------------------|---|--------------------|
| 7542 | 150 | 100 | 50 | | 1-0-32-128-384 / 6 |
| 7543 | 230 | 130 | 70 | | 1-0-12-48-144 / 6 |
| 7546 | 240 | 160 | 70 | | 1-0-12-48-144 / 6 |



Mini caja
 Mini wooden box
 Mini cagette en bois
 Mini cassetta legno
 Mini holzbox

| REF. | L _(mm) | W _(mm) | H _(mm) | € | UE / MOQ |
|-------------|-------------------|-------------------|-------------------|---|--------------------|
| 7539 | 125 | 80 | 90 | | 1-0-24-192-384 / 6 |
| 7540 | 130 | 170 | 90 | | 1-0-12-36-288 / 6 |



DIM-SUM

Vaporera bambú
Bamboo Steamer
Vapocuseur Bambou
Vaporiera Bamboo
Bambusdämpfer



| REF. | Ø(mm) | H(mm) | PISOS | RACIONES | € | UE / MOQ |
|-------|-------|-------|-------|--------------|---|------------|
| 7830 | 100 | 70 | 1 | TAPA | | 1-4-36 / 4 |
| 7831 | 130 | 85 | 1 | RACIÓN | | 1-4-36 / 4 |
| 7832 | 150 | 85 | 1 | INDIVIDUAL | | 1-4-72 / 4 |
| 11966 | 200 | 135 | 2 | 2 RACIONES | | 1-0-8 / 1 |
| 11967 | 250 | 160 | 2 | 3-4 RACIONES | | 1-0-6 / 1 |
| 11968 | 300 | 165 | 2 | 5-6 RACIONES | | 1-0-3 / 1 |

NEW

Papel Perforado Vaporera Bamboo

Perforated Bamboo Steamer Paper
Papier Perforé Vapocuseur Bambou
Foglio Di Carta In Bambu' Perforato Per Vaporiera
Perforiertes Papier Für Bambusdämpfer



| REF. | Ø(mm) | € | UE / MOQ |
|-------|-------|---|-----------------|
| 11969 | 130 | | 1-250-2000/ 250 |
| 11970 | 170 | | 1-250-2000/ 250 |
| 11971 | 280 | | 1-250-2000/ 250 |



Mango hueco para una manipulación más ligera.
Hollow handle for lighter handling.



- A **7421** SET PALILLOS INOX
chopsticks set 18/10, set baguettes 18/10, set bacchettes 18/10, esstübchen set 18/10
- B **7422** SET PALILLOS BLACK
chopsticks set black 18/10, set baguettes black 18/10, set bacchettes black 18/10, esstübchen set 18/10 black
- C **7423** SET PALILLOS COPPER
chopsticks set copper 18/10, set baguettes copper 18/10, set bacchettes copper 18/10, esstübchen set 18/10 copper
- D **7424** SET PALILLOS GOLD
chopsticks set gold 18/10, set baguettes gold 18/10, set bacchettes gold 18/10, esstübchen set 18/10 gold
- E **7554** REPOSA PALILLOS BLOQUE SATIN
chopsticks rest satin 18/10, porte baguette satin 18/10, supporto posate satin 18/10, besteckhalter satin 18/10
- F **7555** REPOSA PALILLOS BLOQUE NEGRO
chopsticks rest black 18/10, porte baguette black 18/10, supporto posate black 18/10, besteckhalter black 18/10

| € | UE | MOQ | ✂ mm | ✂ mm |
|---|--------------------|-----|------|------|
| | 0/12/120/1920/5760 | 12 | 230 | 11 |
| | 0/12/120/1920/5760 | 12 | 230 | 11 |
| | 0/12/120/1920/5760 | 12 | 230 | 11 |
| | 0/12/120/1920/5760 | 12 | 230 | 11 |
| | 0/12/120/1920/5760 | 12 | 60 | 11 |
| | 0/12/120/1920/5760 | 12 | 60 | |

Sakura



FIBRE GLASS

- 6935** SET PALILLOS
chopsticks set 18/10, set piques 18/10, set bacchettes 18/10, esstübchen-set 18/10
- 7869** SOPORTE CUBIERTOS
cutlery holder, panier à pouverts, supporto coperte, besteckhalter

| € | UE | MOQ | ✂ mm | ✂ mm |
|---|------------------|-----|------|------|
| | 0/6/60/1440/4320 | 60 | 228 | |
| | 0/6/60/1440/4320 | 60 | 206 | |



Fondo sellado con silicona que permite contener líquido con total seguridad.

Silicone sealed bottom allows contain liquids safely.



ZINC

Cubo galvanizado
Zinc ice bucket
Seau en acier galvanisé
Cubetto galvanizzato
Zinn-eiskühler

| REF. | SIZE | W(mm) | L(mm) | H(mm) | ml | € | UE / MOQ |
|------|------|-------|-------|-------|-------|---|--------------------|
| 7533 | XL | 350 | 510 | 230 | 24000 | | 1-6-48-192-384 / 1 |
| 7534 | M | 300 | 390 | 187 | 14000 | | 1-8-64-256-512 / 1 |

INOX STAINLESS STEEL 201 COTTON

Enfriador de botella inox
Bottle cooler inox
Glacette inox
Refrigeratore inox
Edelstahlkühle



| REF. | COLOR | Ø(mm) | H(mm) | ml | € | UE / MOQ |
|------|-------|-------|-------|-------|---|------------------|
| 2765 | INOX | 120 | 180 | 1.250 | | 1-0-6-54-162 / 6 |
| 2787 | BEIGE | 120 | 180 | 1.250 | | 1-0-6-54-162 / 6 |
| 2788 | BROWN | 120 | 180 | 1.250 | | 1-0-6-54-162 / 6 |
| 2789 | GREEN | 120 | 180 | 1.250 | | 1-0-6-54-162 / 6 |

INOX STAINLESS STEEL 201

Pie cubo champagnera 2 botellas
Champagne bucket stand 2 bottles
Pied porte-seau champagne 2 bouteilles
Colona portasecchiolo 2b
Ständer f. 2 champagnerkühler



| REF. | Ø(mm) | H(mm) | € | UE / MOQ |
|------|-------|-------|---|-----------------|
| 5653 | 220 | 630 | | 1-0-4-32-64 / 1 |

COMPATIBLE CON: 4967 - 5513 - 3095 (p.413)

INOX STAINLESS STEEL 201

Pie cubo champagnera 1 botella
Champagne bucket stand 1 bottle
Pied porte-seau champagne 1 b.
Colona portasecchiolo 1b.
Ständer f. 1 champagnerkühler



| REF. | H(mm) | € | UE / MOQ |
|------|-------|---|-----------------|
| 2786 | 720 | | 1-0-1-16-80 / 1 |

COMPATIBLE CON: 4967 - 3095 (p.413)

INOX STAINLESS STEEL 201

Soporte cubo mesa
Wine bucket stand support
Support de table pour seau
Supporto secchio tavola
Halter für tischeimer



| REF. | Ø(mm) | € | UE / MOQ |
|------|-------|---|-----------------|
| 7112 | 200 | | 1-0-5-30-60 / 5 |

COMPATIBLE CON:
4967 (p.413)



INOX
STAINLESS
STEEL
201

Servicio mesa / Champangeras y accesorios
Table top / Champagne and accessories

Cubitera tipo ensaladera
Ice cube bowl
Vasque
Coppa con base
Champagner kühler becken



| REF. | Ø(mm) | H(mm) | ml | € | UE / MOQ |
|------|-------|-------|--------|---|-----------------|
| 2727 | 345 | 230 | 10.000 | | 1-0-1-12-12 / 1 |

Cubo champagne 2 bot.
2 bottles champagne bucket
Seau champagne 2 bouteilles
Rinfrescatore champane 2b
Champagner kühler



| REF. | Ø(mm) | H(mm) | ml | € | UE / MOQ |
|------|-------|-------|-------|---|-----------------|
| 5513 | 240 | 215 | 6.500 | | 1-0-4-24-48 / 1 |

Cubo hielo inox
Stainless steel ice bucket
Seau à glace inox
Secchiello ghiaccio
Edelstahl eiseimer



| REF. | Ø(mm) | H(mm) | ml | € | UE / MOQ |
|------|-------|-------|-----|---|-------------------|
| 3093 | 110 | 130 | 800 | | 1-0-20-80-160 / 1 |

Champagnera inox
Stainless steel champagne bucket
Seau à champagne
Secchiello champagne
Champagne eimer



| REF. | Ø(mm) | H(mm) | ml | € | UE / MOQ |
|------|-------|-------|-------|---|-----------------|
| 3095 | 190 | 190 | 3.500 | | 1-0-6-18-54 / 6 |

Cubo hielo Lux
Bucket lux
Seau à glace lux
Secchiello ghiaccio lux
Eiseimer lux



| REF. | Ø(mm) | H(mm) | ml | € | UE / MOQ |
|------|-------|-------|-------|---|------------------|
| 3096 | 120 | 125 | 1.000 | | 1-0-20-80-60 / 1 |

Cubo champagne
Champagne bucket
Seau champagne
Rinfrescatore champane
Champagner kühler



| REF. | Ø(mm) | H(mm) | ml | € | UE / MOQ |
|------|-------|-------|-------|---|------------------|
| 4967 | 200 | 210 | 3.500 | | 1-0-6-42-126 / 6 |

Cubo hielo isotérmico
Double wall plain
Seau à glace isotherme
Secchiello ghiaccio isolato
Isoliert eiseimer



| REF. | Ø(mm) | H(mm) | ml | € | UE / MOQ |
|------|-------|-------|-------|---|-------------------|
| 3097 | 120 | 135 | 1.000 | | 1-0-20-60-120 / 1 |

Cubo hielo
Ice bucket
Seau à glaçons
Secchiello ghiaccio
Eisbehälter



| REF. | Ø(mm) | H(mm) | ml | € | UE / MOQ |
|------|-------|-------|-------|---|---------------------|
| 4968 | 140 | 130 | 1.000 | | 1-0-20-160-320 / 10 |



Servicio mesa / Paneras
Table top / Breadbaskets

Panera redonda kraft lavable 17
Washable round kraft breadbasket 17
Corbeille à pain ronde kraft lavable 17
Portopane rotondo kraft lavabile 17
Baschbarkraft, runder brotkorb 17



| REF. | Ø(mm) | H(mm) | € | UE / MOQ |
|------|-------|-------|---|--------------------|
| 7455 | 170 | 120 | | 1-5-50-200-400 / 5 |



Panera oval kraft lavable
Washable oval kraft breadbasket
Corbeille à pain ovale kraft lavable
Portopane ovale kraft lavabile
Baschbarkraft, ovaler brotkorb



| REF. | W(mm) | L(mm) | H(mm) | € | UE / MOQ |
|------|-------|-------|-------|---|--------------------|
| 7457 | 250 | 180 | 130 | | 1-5-50-200-400 / 5 |

COMPATIBLE CON: 7459 (p.417)



Panera redonda kraft lavable 20
Washable round kraft breadbasket 20
Corbeille à pain ronde kraft lavable 20
Portopane rotondo kraft lavabile 20
Baschbarkraft, runder brotkorb 20



| REF. | Ø(mm) | H(mm) | € | UE / MOQ |
|------|-------|-------|---|--------------------|
| 7456 | 200 | 120 | | 1-5-50-200-400 / 5 |

COMPATIBLE CON: 7459 (p.399)

Material kraft.

Kraft Material

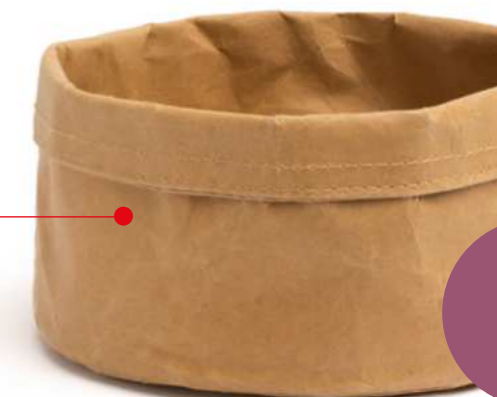

30°C



3 CAPAS LAYERS

COTTON

Panera redonda gris 17
Round grey Breadbasket 17
Corbeille à pain ronde grise 17
Portopane rotondo grigio 17
Grauer, runder brotkorb 17



| REF. | Ø(mm) | H(mm) | € | UE / MOQ |
|------|-------|-------|---|--------------------|
| 7451 | 170 | 100 | | 1-5-50-200-400 / 5 |



Panera redonda gris 20
Round grey Breadbasket 20
Corbeille à pain ronde grise 20
Portopane rotondo grigio 20
Grauer, runder brotkorb 20



| REF. | Ø(mm) | H(mm) | € | UE / MOQ |
|------|-------|-------|---|--------------------|
| 7452 | 200 | 120 | | 1-5-50-200-400 / 5 |

COMPATIBLE CON: 7459 (p.399)



Panera oval gris
Oval grey breadbasket
Cobeille à pain ovale grise
Portopane ovale grigio
Grauer, ovaler brotkorb



| REF. | W(mm) | L(mm) | H(mm) | € | UE / MOQ |
|------|-------|-------|-------|---|--------------------|
| 7453 | 200 | 150 | 100 | | 1-5-50-200-400 / 5 |
| 7454 | 250 | 180 | 120 | | 1-5-50-200-400 / 5 |

COMPATIBLE CON: 7459 (p.399)



Capas exteriores:
100% algodón
Capa interior:
35% algodón
65% poliéster

Outer layers:
100% cotton
Inner layer:
35% cotton
65% polyester

+RIGIDEZ / RIGIDITY





Panera grissini
Breadsticks holder
Corbeille à grissini
Cestino porta grissini
Brotkorb für grissini

3
CAPAS
LAYERS + RIGIDEZ
RIGIDITY

COTTON



| REF. | COLOR | Ø(mm) | H(mm) | € | UE / MOQ |
|------|-------|-------|-------|---|--------------------|
| 7779 | GRIS | 100 | 220 | | 1-5-50-200-400 / 5 |
| 7778 | BEIGE | 100 | 220 | | 1-5-50-200-400 / 5 |

Panera cuadrada 100% algodón
Square breadbasket 100% cotton
Corbeille à pain carrée
Portopane quadrato
Quadratischer brotkorb

COTTON



| REF. | COLOR | W(mm) | L(mm) | H(mm) | € | UE / MOQ |
|------|-------|-------|-------|-------|---|--------------------|
| 7598 | BEIGE | 120 | 120 | 140 | | 1-5-50-200-400 / 5 |
| 7599 | GRIS | 120 | 120 | 140 | | 1-5-50-200-400 / 5 |



Calentador con cerámica térmica
Warmer with ceramic beans
Corbeille à pain thermique
Portopane termico
Thermo-brotkorb

COTTON

| REF. | Ø(mm) | H(mm) | € | UE / MOQ |
|------|-------|-------|---|--------------------|
| 7458 | 200 | 130 | | 1-5-50-200-400 / 5 |



Accesorio cerámica térmica
Ceramic beans warmer bag
Base thermique
Base termica
Thermo-basis



| REF. | Ø(mm) | € | UE / MOQ |
|------|-------|---|--------------------|
| 7459 | 190 | | 1-5-50-200-400 / 5 |

COMPATIBLE CON / COMPATIBLE WITH: (p.397)



7456 7457 7452 7453 7454

INOX
STAINLESS
STEEL
201

Panera inox
Bread basket
Corbeille à pain
Porta pane
Brotkorb



| REF. | Ø(mm) | H(mm) | € | UE / MOQ |
|------|-------|-------|---|---------------------|
| 4952 | 200 | 95 | | 1-4-48-720.3600 / 5 |

BOROSILICATE

+ RESISTENCIA
RESISTANCE

ANTIGOTEO

Set 2 pzas. vinagrera antigoteo
Non drip 2 pieces cruet set
Ménagère, 2 pièces
Servizio oliera, 2 pezzi
Menage, 2-teilig



| REF. | ml | € | UE / MOQ |
|------|-----|---|---------------------|
| 8387 | 260 | | 1-0-12-125-375 / 12 |

BOROSILICATE

+ RESISTENCIA
RESISTANCE

ANTIGOTEO

Botella antigoteo
Non drip bottle
Bouteille anti-goutte
Bottiglia antigoccia
Anti-tropf-flasche



| REF. | ml | € | UE / MOQ |
|------|-----|---|---------------------|
| 8388 | 500 | | 1-0-24-63-189 / 24 |
| 8389 | 250 | | 1-0-36-144-288 / 36 |

GLASS

CUADRADA

Set 2 pzas. vinagrera cuadrada
2 pieces square cruet set
Ménagère, 2 pièces
Servizio oliera, 2 pezzi
Menage, 2-teilig



| REF. | ml | € | UE / MOQ |
|------|-----|---|---------------------|
| 8393 | 250 | | 1-0-24-125-375 / 24 |

GLASS

CUADRADA

Set 4 pzas. vinagrera cuadrada
4 pieces square cruet set
Ménagère, 4 pièces
Servizio oliera, 4 pezzi
Menage, 4-teilig



| REF. | ml | € | UE / MOQ |
|------|-----|---|----------------------|
| 8392 | 250 | | 1-0-12-250-1000 / 12 |

Boquilla fina para verter el líquido con precisión.

Fine spout for precision pouring.

Fácil de rellenar gracias a su boquilla extraíble.

Removable spout makes for easy refilling.

Collar que recoge las gotas que puedan quedar en la boquilla y evita ensuciar la mesa.

Collar that collects any liquid left in the spout and keeps the table clean..

Cuello de vidrio glaseado que fija la boquilla.

Frosted glass collar that keeps the spout in place.

BOROSILICATE



GLASS

PARIS

Vinagrera PARIS 2 piezas
2 pieces cruet set PARIS
Ménagère 2 pièces PARIS
Oliera 2pc. mod. PARIS
2-Teilige menage PARIS



| REF. | ml | € | UE / MOQ |
|------|-----|---|--------------------|
| 3698 | 150 | | 1-0-24-216-216 / 4 |

PARIS

Juego sal pimienta y mostaza
Salt, pepper and mustard set
Ménagère sel, poivre et moutarde
Sale pepe e senape mod.
Salz/pfeffer/senf-set



| REF. | ml | € | UE / MOQ |
|------|-----|---|--------------------|
| 3165 | 150 | | 1-0-24-192-384 / 4 |

INOX

Vinagrera inox 2 piezas
2 pieces cruet set inox
Ménagère 2 pièces inox
Oliera 2pc. inox
2-Teilige menage inox



| REF. | ml | € | UE / MOQ |
|------|-----|---|--------------------|
| 3164 | 175 | | 1-0-24-144-144 / 4 |

Blister 2 saleros
Blister 2 salt shakers
Blister 2 salières
Blister 2 salino
Blister 2 glas-salzstreuer



| REF. | € | UE / MOQ |
|------|---|----------------------|
| 5160 | | 1-0-100-400-400 / 10 |

PARIS

Vinagrera PARIS 4 piezas
4 pieces cruet set PARIS
Ménagère 4 pièces PARIS
Oliera 4pc. mod. PARIS
4-Teilige menage PARIS



| REF. | ml | € | UE / MOQ |
|------|-----|---|-------------------|
| 3697 | 150 | | 1-0-24-96-192 / 4 |

PARIS

Juego sal y pimienta PARIS
Salt & pepper set PARIS
Ménagère sel et poivre PARIS
Sale e pepe mod. PARIS
Salz/pfeffer-set PARIS



| REF. | € | UE / MOQ |
|------|---|---------------------|
| 3699 | | 1-12-72-432-864 / 4 |

INOX

Vinagrera inox 4 piezas
4 pieces cruet set inox
Ménagère 4 pièces inox
Oliera 4 pc. inox
4-Teilige menage inox



| REF. | ml | € | UE / MOQ |
|------|-----|---|------------------|
| 3103 | 175 | | 1-0-24-96-96 / 4 |

NEW YORK

Vinagrera 4 piezas PVC
4 pieces PVC cruet set
Ménagère 4 pièces
Oliera 4pc.
4-Teilige Menage



| REF. | ml | € | UE / MOQ |
|------|-----|---|------------------|
| 5159 | 150 | | 1-0-24-96-96 / 4 |



Caja salsa
Table caddies
Cagette sauces
Cassetta per salse
Tisch organizer



| REF. | W(mm) | L(mm) | H(mm) | € | UE / MOQ |
|------|-------|-------|-------|---|------------------|
| 7840 | 200 | 150 | 180 | | 1-0-12-36-72 / 1 |



CUADRADA

Botella cuadrada
Square oil bottle
Ménagère carré
Oliera quadrata
Square menage



| REF. | ml | H(mm) | € | UE / MOQ |
|------|-----|-------|---|--------------------|
| 8390 | 250 | 250 | | 1-0-36-84-168 / 36 |

CUADRADA

Soporte 2 pzas. vinagrera cuadrada
Stand 2 pieces square cuet set
Porte huile et vinaigre
Porta olio/acetato
Essig u. Öl-stand



| REF. | H(mm) | € | UE / MOQ |
|------|-------|---|---------------------|
| 8394 | 285 | | 1-0-24-126-252 / 24 |



Bandeja ovalada
Oval heavy try
Plateau ovale
Vassoio ovale
Tablett oval

| REF. | W(mm) | L(mm) | € | UE / MOQ |
|------|-------|-------|---|---------------------|
| 7093 | 170 | 250 | | 1-0-24-336-1344 / 6 |
| 7094 | 210 | 300 | | 1-0-24-264-1056 / 6 |
| 7095 | 235 | 350 | | 1-0-24-192-576 / 6 |
| 7096 | 270 | 400 | | 1-0-24-168-504 / 6 |
| 7097 | 295 | 450 | | 1-0-24-96-384 / 6 |
| 7098 | 340 | 500 | | 1-0-24-96-384 / 6 |
| 7099 | 415 | 600 | | 1-0-20-40-160 / 6 |

Bandeja 12 rec. vinagrera PARIS
Pack 12 oil/vinegar bottle PARIS
Pack 12 bouteilles recharge PARIS
Pack 12 rec. oliera PARIS
12 teilige PARIS



| REF. | ml | € | UE / MOQ |
|------|-----|---|-----------------|
| 3783 | 150 | | 1-0-8-40-80 / 4 |

Bandeja 12 saleros Paris
Salt/pepper shakers PARIS
Salières PARIS
Sale PARIS
Ersalzflaschen PARIS



| REF. | H(mm) | € | UE / MOQ |
|------|-------|---|--------------|
| 3905 | 90 | | 1-12-300 / 1 |

CUADRADA

Tapón vinagrera cuadrada
Cap square bottle
Bouchon de burette
Tappo di oliera
Menage stopper



| REF. | € | UE / MOQ |
|------|---|---------------|
| 8391 | | 1-12-300 / 12 |



Bandeja pescado
Fish tray
Plateau poisson
Piatto pesce
Fischtablett

| REF. | W(mm) | L(mm) | € | UE / MOQ |
|------|-------|-------|---|-------------------|
| 7100 | 250 | 600 | | 1-0-20-80-400 / 6 |
| 7101 | 258 | 700 | | 1-0-20-80-400 / 6 |



BAR COCKTAIL



406 SERVICIO MESA
/ TABLE TOP

**408 COCTELERÍA
Y ACCESORIOS**
/ COCKTAILS AND ACCESSORIES



Tratamiento antideslizante:
Textura engomada que evita que los objetos se deslicen por la superficie con el movimiento.

Anti-slip:
Rubbery surface texture that keeps pieces in place while you carry them.



Fabricada en FIBERGLASS la convierte en una bandeja muy ligera, indeformable y apta para lavavajillas.

Made in FIBERGLASS, this tray is very light, unbendable and dishwasher safe.

PP
POLYPROPYLENE



Bandeja antideslizante
Non slip serving tray
Plateau de service antidérapant
Vassoio antiscivolo
Rutschfestes serviertablett

| REF. | Ø(mm) | € | UE / MOQ |
|------|-------|---|--------------------|
| 8413 | 360 | | 1-0-12-72-504 / 12 |
| 8414 | 400 | | 1-0-12-72-216 / 12 |

FIBER-GLASS



Bandeja FIBERGLASS antideslizante
FB round non slip serving tray
Plateau de service rond antidérapant FB
Piatto da portata rotondo antiscivolo FB
Rutschfreies rundes FB serviertablett

| REF. | Ø(mm) | € | UE / MOQ |
|------|-------|---|--------------------|
| 8420 | 360 | | 1-0-12-72-482 / 12 |
| 8421 | 400 | | 1-0-12-72-216 / 12 |

FIBER-GLASS



Bandeja FIBERGLASS antideslizante rectangular
FB rectangle non slip serving tray
Plateau de service rectangle antidérapant FB
Piatto da portata rettangolare antiscivolo FB
Rutschfreies rechteck FB serviertablett

| REF. | W(mm) | L(mm) | € | UE / MOQ |
|------|-------|-------|---|--------------------|
| 8415 | 360 | 460 | | 1-0-12-48-336 / 12 |
| 8416 | 380 | 510 | | 1-0-12-48-192 / 12 |
| 8417 | 400 | 560 | | 1-0-12-48-192 / 12 |

FIBER-GLASS



Bandeja FIBERGLASS antideslizante oval
FB oval non slip serving tray
Plateau de service ovale antidérapant FB
Piatto da portata ovale antiscivolo FB
Rutschfreies oval FB serviertablett

| REF. | W(mm) | L(mm) | € | UE / MOQ |
|------|-------|-------|---|-----------------|
| 8418 | 560 | 680 | | 1-0-6-12-27 / 6 |

BEECH
WOOD



Soporte bandeja
Tray support
Support de plateau
Supporto vassoio
Unterstützung serviertablett

| REF. | W(mm) | L(mm) | H(mm) | € | UE / MOQ |
|------|-------|-------|-------|---|----------------|
| 8419 | 440 | 433 | 835 | | 1-0-1-3-20 / 1 |

INOX
STAINLESS
STEEL
201



Bandeja camarero
Serving tray
Plateau barman
Vassoio bar
Serviertablett

| REF. | Ø(mm) | € | UE / MOQ |
|------|-------|---|-------------------|
| 4950 | 400 | | 1-0-12-72-432 / 6 |

INOX
STAINLESS
STEEL
201



Coctelera delux
Cocktail shaker delux
Shaker delux
Shaker per cocktail delux
Cocktailshaker delux

| REF. | H(mm) | ml | € | UE / MOQ |
|------|-------|-----|---|--------------------|
| 3024 | 190 | 750 | | 1-0-24-192-192 / 1 |
| 3023 | 165 | 500 | | 1-0-24-120-120 / 1 |



60 ml
30 ml

Vaso medidor
Measuring cup
Verre mesureur
Misurino cocktail
Messglas

| REF. | H(mm) | ml | € | UE / MOQ |
|------|-------|---------|---|----------------------|
| 3021 | 100 | 30 / 60 | | 1-24-96-384-1920 / 6 |



Cuchara coctel
Cocktail spoon
Cuillère cocktail
Cucchiaio cocktail
Cocktailöffel

| REF. | L(mm) | € | UE / MOQ |
|------|-------|---|-------------------------|
| 3151 | 290 | | 1-12-120-1080-2160 / 12 |



Coctelera con filtro
Cocktail shaker w / filter
Shaker avec filtre
Shaker per cocktail filtro
Cocktailshaker mit filter

| REF. | H(mm) | ml | € | UE / MOQ |
|------|-------|-----|---|--------------------|
| 3022 | 190 | 500 | | 1-0-24-120-120 / 1 |



Colador gusanillo
Bar strainer Mickey mouse
Passoir à cocktail mickey mouse
Colino cocktail mickey mouse
Barstrainer mickey mouse

| REF. | L(mm) | € | UE / MOQ |
|------|-------|---|----------------------|
| 3027 | 145 | | 1-24-96-768-2304 / 6 |



Cuchara sangría
Sangría spoon
Cuillère sangria
Cucchiaio sangria
Sangriöffel

| REF. | L(mm) | € | UE / MOQ |
|------|-------|---|-------------------------|
| 2728 | 270 | | 1-12-120-1920-9600 / 12 |

INOX
STAINLESS
STEEL
430

INOX
STAINLESS
STEEL
201

Cenicero agua
Water ashtray
Cendrier eau
Portacenere
Wasser-aschenbecher



| REF. | Ø(mm) | H(mm) | € | UE / MOQ |
|------|-------|-------|---|--------------------|
| 4951 | 95 | 38 | | 1-0-96-768-768 / 6 |

Jarra agua
Water jug
Carafe d'eau
Caraffa d'acqua
Wasserkaraffe



| REF. | Ø(mm) | H(mm) | ml | € | UE / MOQ |
|------|-------|-------|-------|---|------------------|
| 3030 | 100 | 145 | 1.250 | | 1-0-6-48-144 / 6 |

Servilletero
Napkin dispenser
Distributeur serviettes
Portasalviette
Serviettenhalter



| REF. | W(mm) | H(mm) | € | UE / MOQ |
|------|-------|-------|---|--------------------|
| 5039 | 130 | 100 | | 1-0-24-144-288 / 6 |

Pisamanteles pack 4
Tablecloth clip
Clips nappe
Molle fermatovaglia
Teilige tischdeckenklipse



| REF. | € | UE / MOQ |
|------|---|------------------------|
| 3456 | | 1-0-100-1500-4500 / 25 |

Sacacorchos
Waiter's corkscrew
Tire-bouchon de serveur
Cavatappi cameriere
Kellnermesser



| REF. | L(mm) | € | UE / MOQ |
|------|-------|---|-----------------------|
| 8479 | 120 | | 1-12-72-720-2880 / 24 |

Cenicero abierto
Round ashtray
Cendrier
Portacenere
Offener aschenbecher



| REF. | Ø(mm) | H(mm) | € | UE / MOQ |
|------|-------|-------|---|---------------------|
| 7113 | 100 | 35 | | 1-0-90-720-1440 / 6 |

Placa reservado
Table tag reservado
Plaquette de table reservado
Targhetta tavola reservado
Tischaufsteller reservado



| REF. | W(mm) | € | UE / MOQ |
|------|-------|---|-------------------------|
| 9709 | 190 | | 1-25-100-1200-4800 / 25 |

Soporte copas
Glass racks
Support verres à pied
Cremagliera di vetro
Glashalter



| REF. | L(mm) | € | UE / MOQ |
|------|-------|---|--------------------|
| 3102 | 400 | | 1-0-24-144-432 / 6 |
| 3098 | 600 | | 1-0-24-144-432 / 6 |

Plato cambio
Bill holder
Plateau addition
Porta monette
Rechnungshalter



| REF. | W(mm) | L(mm) | € | UE / MOQ |
|------|-------|-------|---|-----------------------|
| 5002 | 170 | 100 | | 1-0-100-800-1600 / 10 |

Pala recogemigas
Table crumbler
Ramasse-miettes
Paletta per briciola
Tisch-krümelkehrer



| REF. | L(mm) | € | UE / MOQ |
|------|-------|---|---------------------|
| 3028 | 280 | | 1-0-24-288-1152 / 6 |



Alfombra para barra estrecha

Bar mats
Dessus-de-table pour comptoir de bar
Tappetino bar
Gläserabstellmatte

| REF. | W(mm) | L(mm) | € | UE / MOQ |
|------|-------|-------|---|--------------------|
| 8427 | 85 | 650 | | 1-0-16-96-768 / 16 |



Alfombra para barra ancha

Bar mats
Dessus-de-table pour comptoir de bar
Tappetino bar
Gläserabstellmatte

| REF. | W(mm) | L(mm) | € | UE / MOQ |
|------|-------|-------|---|--------------------|
| 8428 | 300 | 450 | | 1-0-15-60-240 / 15 |



Tapón dosificador

Flow pourers
Bec verseur
Tappo versatore dosatore
Dosierausgiesser

| REF. | Ø(mm) | H(mm) | € | UE / MOQ |
|------|-------|-------|---|-----------------------|
| 8426 | 40 | 110 | | 1-10-100-500-500 / 60 |



Organizador de bar

Bar organizer
Organisateur de bar
Portacondimenti
Barcaddy

| REF. | W(mm) | L(mm) | H(mm) | € | UE / MOQ |
|------|-------|-------|-------|---|-------------------|
| 8432 | 148 | 240 | 110 | | 1-0-12-24-72 / 12 |



Recipientes coctelería

Containers for cocktail shaker
Récipients pour cocktails
Portacondimenti
Bar-beilagenbehälte

| REF. | W(mm) | L(mm) | H(mm) | € | UE / MOQ |
|------|-------|-------|-------|---|------------------|
| 8433 | 156 | 492 | 90 | | 1-0-12-24-72 / 1 |



NEW



Tabla Corte Negra
Black Cutting Board
Planche à découper Noir
Tagliere Nero
Schwarz Schneidebrett

| REF. | WxL cm | ESPESOR cm | TACOS | € | UE / MOQ |
|-------|--------|------------|-------|---|-----------|
| 11760 | 30x20 | 2 | 4 | | 1-0-8 / 1 |
| 11759 | 40x30 | 2 | 4 | | 1-0-6 / 1 |

Cuchillo chuletero
Steak knife
Couteau steak
Coltello bistecca
Steakmesser

| REF. | HOJA (mm) | L (mm) | € | UE / MOQ |
|-------|-----------|--------|---|----------------------|
| 11585 | 120 | 230 | | 1-0-24-360-1440 / 24 |

Cuchillo multiusos micro
Micro serrated utility knife
Couteau multi-usage micro
Coltello multiuso micro
Universalmesser micro

| REF. | HOJA (mm) | L (mm) | € | UE / MOQ |
|-------|-----------|--------|---|----------------------|
| 11587 | 100 | 209 | | 1-0-24-360-1440 / 24 |

Cuchillo pelador
Peeling knife
Couteau à éplucher
Coltello spellucchino
Schälmesser

| REF. | HOJA (mm) | L (mm) | € | UE / MOQ |
|-------|-----------|--------|---|----------------------|
| 11586 | 80 | 195 | | 1-0-24-360-1440 / 24 |

Colador inox
Oil strainer
Passoire à huile
Colino per l'olio
Ölsieb

| REF. | Ø (mm) | € | UE / MOQ |
|------|--------|---|---------------------|
| 2884 | 80 | | 1-0-24-960-1920 / 6 |
| 2885 | 100 | | 1-0-24-960-1920 / 6 |



ABS PLASTIC
FOOD CONTACT

Ribeteador de vasos
Glass rimmer
Bordeuse de verres
Bordatore bicchieri
Bar-kombination salz-zuckerumrand

| REF. | Ø (mm) | H (mm) | € | UE / MOQ |
|------|--------|--------|---|--------------------|
| 8431 | 160 | 72 | | 1-0-12-48-144 / 12 |

PP POLYPROPYLENE

Cesta cubiertos gris
Cutlery dispenser
Récipient à couverts
Portaposate
Besteckbehälter

| REF. | W (mm) | L (mm) | H (mm) | € | UE / MOQ |
|------|--------|--------|--------|---|--------------------|
| 8429 | 290 | 525 | 98 | | 1-0-12-48-144 / 12 |

PP POLYPROPYLENE
FOOD CONTACT

Botella bar
Bar bottle with caps
Bouteille de bar
Contenitore di riserva
Dosier-vorratsbehälter, komplett

| REF. | ml | Ø (mm) | H (mm) | € | UE / MOQ |
|------|-------|--------|--------|---|---------------------|
| 8434 | 500 | 95 | 270 | | 1-0-36-144-576 / 12 |
| 8435 | 1.000 | 95 | 330 | | 1-0-48-192-576 / 12 |
| 8436 | 2.000 | 120 | 353 | | 1-0-36-108-324 / 6 |

FOOD CONTACT

Accesorios botella bar
Bar bottle accessories
Accessoires pour bouteilles de bar
Accessori per contenitore di riserva
Zubehör für Dosier-vorratsbehälter

| REF. | PACK | € | UE / MOQ |
|------|--------|---|------------------------|
| 8962 | PACK 4 | | 1-12-120-360-2520 / 12 |
| 8963 | PACK 4 | | 1-12-120-360-1080 / 12 |



8963

PACK 4



PP POLYPROPYLENE



8962

PACK 4



PC POLYCARBONATE



BUFFET

BUFFET

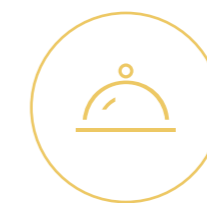

416 CAJAS MADERA
/ WOOD BOXS

420 TABLAS PRESENTACIÓN
/ PRESENTATION BOARDS

422 ACCESORIOS
/ ACCESSORIES

423 JARRAS Y LECHERAS

424 ELEGANT

424 COLOR BUFFET

425 PINZAS

428 KIT SERVIR

430 PINZAS / TONGS



*medidas interiores / internal dimensions

ALTURAS DE CUBETAS GN COMPATIBLES
COMPATIBLE GN TRAY HEIGHTS

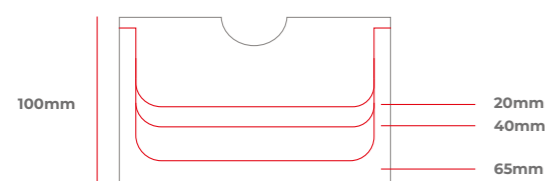

Los accesorios GN quedan encajados en el interior de las cajas, apoyados sobre las esquinas.

GN accessories fit inside the boxes, rested over the corners.



7833



7836



7834



7835



7541

Caja haya

Beech wood box
Cagette en bois
Cassetta legno
Holzbox für behälter

| REF. | GN | W(mm) | L(mm) | H(mm) | € | UE / MOQ |
|------|-----|-------|-------|-------|---|------------------|
| 7833 | 1/1 | 325 | 530 | 100 | | 1-0-4-16-24 / 1 |
| 7834 | 1/2 | 265 | 325 | 100 | | 1-0-4-32-52 / 1 |
| 7835 | 1/3 | 176 | 325 | 100 | | 1-0-6-36-72 / 1 |
| 7541 | 1/4 | 265 | 162 | 100 | | 1-0-6-48-144 / 1 |
| 7836 | 2/4 | 162 | 530 | 100 | | 1-0-4-32-48 / 1 |



Cajas diseñadas para contener cualquier cubeta o accesorio GN.

Designed to contain whatever pail or GN accessory.



PACKAGING STICKER



Cajas madera y alzadores
Wood box and height adjusters

Soporte alzador cajas madera

Structure height adjuster
Support réhausseur
Telaio per alzata
Strukturierter höhenregulator



| REF. | W(mm) | L(mm) | H(mm) | € | UE / MOQ |
|------|-------|-------|-------|---|-----------------|
| 7838 | 325 | 530 | 100 | | 1-0-4-16-48 / 1 |

Soporte alzador cajas madera

Structure height adjuster
Support réhausseur
Telaio per alzata
Strukturierter höhenregulator



| REF. | W(mm) | L(mm) | H(mm) | € | UE / MOQ |
|------|-------|-------|-------|---|-----------------|
| 7837 | 325 | 530 | 180 | | 1-0-4-16-16 / 1 |

Alzador cajas madera

Height adjuster wood boxes
Réhausseur boîte en bois
Supporto per cassetta legno
Höhenregulator für Holzboxen



| REF. | W(mm) | L(mm) | H(mm) | € | UE / MOQ |
|------|-------|-------|-------|---|----------------------|
| 7839 | 40 | 40 | 60 | | 1-4-64-1024-4096 / 4 |

Pinza servir haya punta redonda

Round head beechwood server tong
Pince à servir en bois à bout rond
Molla servire legno punta rotonda
Holzservierzange, runder kopf



Punta ondulada
Wavy tip

| REF. | L(mm) | € | UE / MOQ |
|------|-------|---|---------------------|
| 7549 | 305 | | 1-12-72-432-864 / 6 |

Pinza servir haya punta fina

Slim head beechwood server tong
Pince à servir en bois à bout fin
Molla servire legno a punta
Holzservierzange, dünner kopf



Punta estriada
Ribbed tip

| REF. | L(mm) | € | UE / MOQ |
|------|-------|---|---------------------|
| 7550 | 305 | | 1-12-72-432-864 / 6 |



PACKAGING BLISTER



La manera de presentar los alimentos en el buffet de un hotel puede determinar la opinión de los clientes respecto a este.

En Comas te ofrecemos una amplia gama de material profesional para vestir tu buffet. Cajas de madera para cubrir las cubetas GN, gran surtido de pinzas y piezas de servir, jarras, vajillas,...

Descubre todas las combinaciones que puedes conseguir con nuestra selección buffet.

The way of presenting food in a hotel buffet can determine the opinion of the customers about it.

At Comas we offer you a wide range of professional material to dress up your buffet. Wooden boxes to cover GN trays, a wide range of tongs and serving pieces, jugs, crockery,...

Discover all the combinations you can achieve with our buffet selection.

Buffet

NEW



KIT:



VER REFERENCIAS EN PAG 399

| REF. KIT | REF. TABLA + REF. ARO | = | DESCRIPCIÓN | € | UE / MOQ |
|----------|-----------------------|---|--------------------------------|---|---------------|
| 11170 | 9985 10648 | | TABLA SLIM S + ARO SLIM BAJO | | 1-0-0-0-0 / 1 |
| 11171 | 9985 10649 | | TABLA SLIM S + ARO SLIM ALTO | | 1-0-0-0-0 / 1 |
| 11172 | 9986 10648 | | TABLA SLIM M + ARO SLIM BAJO | | 1-0-0-0-0 / 1 |
| 11173 | 9986 10649 | | TABLA SLIM M + ARO SLIM ALTO | | 1-0-0-0-0 / 1 |
| 11174 | 9987 10648 | | TABLA SLIM L + ARO SLIM BAJO | | 1-0-0-0-0 / 1 |
| 11175 | 9987 10649 | | TABLA SLIM L + ARO SLIM ALTO | | 1-0-0-0-0 / 1 |
| 11176 | 9988 10648 | | TABLA SLIM XL + ARO SLIM BAJO | | 1-0-0-0-0 / 1 |
| 11177 | 9988 10649 | | TABLA SLIM XL + ARO SLIM ALTO | | 1-0-0-0-0 / 1 |
| 11178 | 9989 10719 | | TABLA WIDTH S + ARO WIDTH BAJO | | 1-0-0-0-0 / 1 |
| 11179 | 9989 10720 | | TABLA WIDTH S + ARO WIDTH ALTO | | 1-0-0-0-0 / 1 |
| 11180 | 9990 10719 | | TABLA WIDTH M + ARO WIDTH BAJO | | 1-0-0-0-0 / 1 |
| 11181 | 9990 10720 | | TABLA WIDTH M + ARO WIDTH ALTO | | 1-0-0-0-0 / 1 |

Madera y pizarra / Wood and slate

Tablas presentación Presentation boards



Pizarra + Base acacia
Slate board + Acacia base
Ardoise + Socle acacia
Ardesia + Base in acacia
Schiefer + Basis aus akazie

* Acabado brillo / Gloss finish

| REF. | L(mm) | W(mm) | H(mm) | € | UE / MOQ |
|-------|-------|-------|-------|---|---------------|
| 11574 | 550 | 345 | 20 | | 1-0-0-0-0 / 1 |
| 11575 | 340 | 285 | 15 | | 1-0-0-0-0 / 1 |
| 11576 | 340 | 195 | 15 | | 1-0-0-0-0 / 1 |
| 11577 | 320 | 320 | 15 | | 1-0-0-0-0 / 1 |

SLATE

Pizarra
slate board
Ardoise
Ardesia
Schiefer



| REF. | FORMATO | L(mm) | W(mm) | H(mm) | € | UE / MOQ | COMPATIBLE CON / COMPATIBLE WITH: |
|-------|---------|-------|-------|-------|---|----------------|--------------------------------------|
| 11002 | 1/1 | 530 | 325 | 5 | | 1-0-6-0-0 / 4 | 11005, 11006, 11007, 11573 |
| 11003 | 1/2 | 325 | 265 | 5 | | 1-0-10-0-0 / 4 | |
| 11004 | 1/3 | 325 | 175 | 5 | | 1-0-15-0-0 / 4 | |
| 11572 | | 300 | 300 | 5 | | 1-0-0-0-0 / 1 | |



Base madera para pizarra
Base for slate tray
Socle pour plateau ardoise
Base per vassoio in ardesia
Basis für schieferfach



| REF. | L(mm) | W(mm) | H(mm) | € | UE / MOQ | COMPATIBLE CON / COMPATIBLE WITH: |
|-------|-------|-------|-------|---|----------------|--------------------------------------|
| 11005 | 550 | 345 | 20 | | 1-0-10-0-0 / 4 | 11002, 11003, 11004, 11572 |
| 11006 | 345 | 285 | 15 | | 1-0-20-0-0 / 4 | |
| 11007 | 345 | 195 | 15 | | 1-0-4-0-0 / 4 | |
| 11573 | 320 | 320 | 15 | | 1-0-0-0-0 / 1 | |



4 compartimentos para almacenar un servicio de mesa básico.

4 compartments to store a basic table service.

Cómodas asas laterales para un transporte fácil.

Comfortable side handles for easy carrying.



BOROSILICATE

+ RESISTENCIA
RESISTANCE

Jarra cristal tapón corcho
Glass jar with cork lid
Pichet en verre avec couvercle liège
Caraffa in vetro con coperchio in sughero
Glaskrug mit korkdeckel

| REF. | Ø(mm) | H(mm) | ml | € | UE / MOQ |
|-------|-------|-------|-------|---|--------------------|
| 10806 | 105 | 178 | 1.200 | | 1-0-24-96-288 / 24 |
| 10807 | 105 | 255 | 1.800 | | 1-0-12-48-192 / 24 |

GLASS

Jarra cristal
Glass bottle
Bouteille en verre
Bottigliette
Glasflasche

| REF. | Ø(mm) | H(mm) | ml | € | UE / MOQ |
|------|-------|-------|-------|---|---------------------|
| 8395 | 95 | 270 | 1.000 | | 1-0-12-96-288 / 12 |
| 8396 | 78 | 200 | 500 | | 1-0-24-125-375 / 24 |

OAK WOOD

Caja madera portacubiertos
Wood cutlery box
Plateu à couverts en bois
Portaposate legno
Besteckbehäl aus holz

| REF. | W(mm) | L(mm) | H(mm) | € | UE / MOQ |
|------|-------|-------|-------|---|------------------|
| 8473 | 150 | 280 | 70 | | 1-0-6-54-216 / 4 |

PC POLYCARBONATE **BPA FREE** **FOOD CONTACT**

Vertedor antigoteo
Anti-drip spout

Jarra policarbonato
Polycarbonate jug
Pichet en polycarbonate
Caraffa
Wasserkrug

| REF. | Ø(mm) | H(mm) | ml | € | UE / MOQ |
|------|-------|-------|-------|---|--------------------|
| 8437 | 110 | 185 | 1.000 | | 1-0-12-60-300 / 12 |
| 8438 | 129 | 220 | 1.750 | | 1-0-12-36-180 / 12 |

INOX STAINLESS STEEL 201

Jarra agua
Water jug
Carafe d'eau
Caraffa d'acqua
Wasserkaraffe

| REF. | Ø(mm) | H(mm) | ml | € | UE / MOQ |
|------|-------|-------|-------|---|------------------|
| 3030 | 100 | 145 | 1.250 | | 1-0-6-48-144 / 6 |

COLOR Buffet
ELEGANT COLLECTION

Espatula servir
Serving spatula
Spatule à service
Spatula arrosto
Servirspatel

| REF. | COLOR | L(mm) | € | UE / MOQ |
|------|-----------|-------|---|------------------|
| 5259 | BLACK | 280 | | 1-10-50-0-0 / 10 |
| 5262 | COPPER | 280 | | 1-10-50-0-0 / 10 |
| 5265 | CHAMPAGNE | 280 | | 1-10-50-0-0 / 10 |



Cazo sopa
Soup ladle
Louche à potage
Mestolo sopa
Suppenkelle

| REF. | COLOR | L(mm) | € | UE / MOQ |
|------|-----------|-------|---|------------------|
| 5260 | BLACK | 265 | | 1-10-50-0-0 / 10 |
| 5263 | COPPER | 265 | | 1-10-50-0-0 / 10 |
| 5266 | CHAMPAGNE | 265 | | 1-10-50-0-0 / 10 |

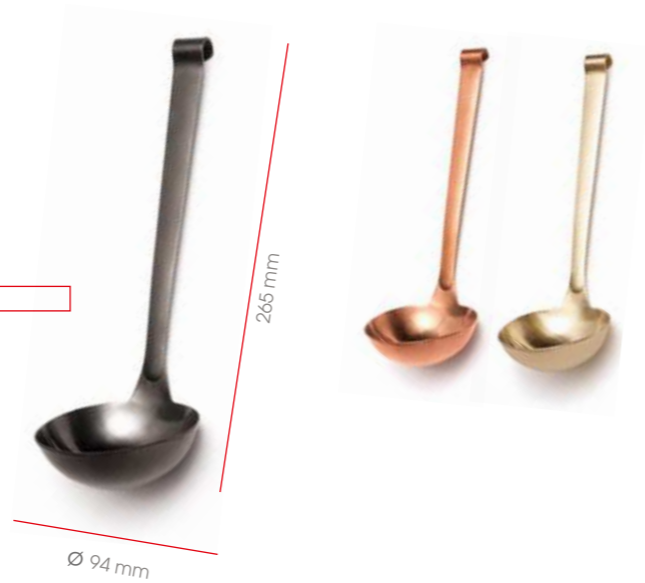

Cuchara servir
Serving spoon
Cuillère à servir
Cucchiaio servir
Servierlöffel

| REF. | COLOR | L(mm) | € | UE / MOQ |
|------|-----------|-------|---|------------------|
| 5261 | BLACK | 300 | | 1-10-50-0-0 / 10 |
| 5264 | COPPER | 300 | | 1-10-50-0-0 / 10 |
| 5267 | CHAMPAGNE | 300 | | 1-10-50-0-0 / 10 |



Elegant
Pinzas / Tongs

Pinza hielo
Ice tong
Pince à glaçon
Molla ghiaccio
Eiswürflzange

| REF. | COLOR | L(mm) | € | UE / MOQ |
|------|---------------------|-------|---|-----------------------|
| 6767 | INOX MIRROR | 190 | | 1-10-100-600-600 / 10 |
| 6768 | PVD BLACK SATIN | 190 | | 1-10-100-600-600 / 10 |
| 6769 | PVD CHAMPAGNE SATIN | 190 | | 1-10-100-600-600 / 10 |
| 6770 | PVD COPPER SATIN | 190 | | 1-10-100-600-600 / 10 |



Pinza servir
Serving tong
Pince à service
Molla arrosto
Servierzange

| REF. | COLOR | L(mm) | € | UE / MOQ |
|------|---------------------|-------|---|-----------------------|
| 6775 | INOX MIRROR | 240 | | 1-10-100-600-600 / 10 |
| 6776 | PVD BLACK SATIN | 240 | | 1-10-100-600-600 / 10 |
| 6777 | PVD CHAMPAGNE SATIN | 240 | | 1-10-100-600-600 / 10 |
| 6778 | PVD COPPER SATIN | 240 | | 1-10-100-600-600 / 10 |



Pinza pasteles
Cake tong
Pince à gâteau
Molla dolce
Gebäckzange

| REF. | COLOR | L(mm) | € | UE / MOQ |
|------|---------------------|-------|---|-----------------------|
| 6779 | INOX MIRROR | 240 | | 1-10-100-600-600 / 10 |
| 6780 | PVD BLACK SATIN | 240 | | 1-10-100-600-600 / 10 |
| 6781 | PVD CHAMPAGNE SATIN | 240 | | 1-10-100-600-600 / 10 |
| 6782 | PVD COPPER SATIN | 240 | | 1-10-100-600-600 / 10 |



Pinza Spaghetti
Spaghetti tong
Pince spaghetti
Molla spaghetti
Spahettizange

| REF. | COLOR | L(mm) | € | UE / MOQ |
|------|---------------------|-------|---|-----------------------|
| 6771 | INOX MIRROR | 240 | | 1-10-100-600-600 / 10 |
| 6772 | PVD BLACK SATIN | 240 | | 1-10-100-600-600 / 10 |
| 6773 | PVD CHAMPAGNE SATIN | 240 | | 1-10-100-600-600 / 10 |
| 6774 | PVD COPPER SATIN | 240 | | 1-10-100-600-600 / 10 |



PACKAGING
BLISTER

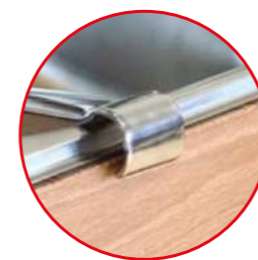

Diseño del mango especialmente pensado para colgar o apoyar en las bandejas de buffet.

Handle specially designed to be hang or supported on the buffet trays.

Elegant

Kit Servir 18/10 / Serving Kit 18/10

Elegant nace de un diseño propio con la intención de dotar al buffet de unos accesorios de calidad pensados para la practicidad del usuario.

Consta de 13 piezas de servir y 4 tipos de pinzas diseñadas específicamente para cubrir las necesidades del autoservicio en catering y buffet.

Elegant was born from an own design with the intention of providing to the buffet with quality accessories intended for the user practicality.

It is composed of 13 serving pieces and 4 different tongs designed specifically to cover the self-service needs in catering and buffet.



Buffet
ELEGANT COLLECTION



Bandeja reposa utensilio
Utensil rest tray
Plateau repos des ustensiles
Vassoio Riposo per l'utensile
Repository-Werkzeug tablett



| REF. | W(mm) | L(mm) | H(mm) | € | UE / MOQ |
|------|-------|-------|-------|--------------|----------------------|
| 7960 | 145 | 195 | 17 | 35,09 | 1-10-50-200-1000 / 1 |
| 7889 | 110 | 155 | 12 | 30,29 | 1-10-50-200-1000 / 1 |

PACKAGING BLISTER



INOX
STAINLESS
STEEL
304

Elegant

Kit Servir 18/10 / Serving Kit 18/10

PACKAGING BLISTER



| | REF. | DESCRIPTION | UE | MOQ | L mm | W mm |
|---|------|--|------------------|-----|------|--------|
| A | 6597 | TENEDOR ENSALADA salad fork fourchette salade forchetta insalata salatgabel | 1/10/50/200/1000 | 10 | 250 | 60x85 |
| B | 6594 | CUCHARA RANURADA slotted spoon cuillère à servir percée cucchiaio asolati skimmer | 1/10/50/200/1000 | 10 | 300 | 70x98 |
| C | 7116 | ESPUMADERA skimer écumeoire schiumarola schaumlöffel | 1/10/50/200/1000 | 10 | 320 | Ø 100 |
| D | 6589 | TENEDOR CARNE meat fork fourchette viande forchetta carne fleischgabel | 1/10/50/200/1000 | 10 | 300 | 35x90 |
| E | 6590 | ESPÁTULA spatula spatule spatula spatel | 1/10/50/200/1000 | 10 | 280 | 82x100 |
| F | 6592 | CUCHARA SPAGHETTI spaguetti spoon cuillère à spaghetti cucchiaio spaguetti spaghetti löffel | 1/10/50/200/1000 | 10 | 300 | 73x90 |
| G | 6595 | PALA REPOSTERÍA cake server pelle à tarte pala torta gebäck schaufel | 1/10/50/200/1000 | 10 | 300 | 75x140 |

| | REF. | DESCRIPTION | UE | MOQ | L mm | W mm | ml |
|---|------|--|------------------|-----|------|--------|-----|
| H | 6593 | CUCHARA SERVIR serving spoon cuillère à servir cucchiaio servir servierlöffel | 1/10/50/200/1000 | 10 | 300 | 70x98 | |
| I | 6599 | CUCHARA ENSALADA salad spoon cuillère salade cucchiaio salate salatlöffel | 1/10/50/200/1000 | 10 | 250 | 60x85 | |
| J | 7958 | CAZO SALSA sauce ladle cuillère à sauce mestolino salsa soßenkelle | 1/10/50/200/1000 | 10 | 295 | Ø 60 | 30 |
| K | 6607 | CAZO SALSA sauce ladle cuillère à sauce mestolino salsa soßenkelle | 1/10/50/200/1000 | 10 | 260 | Ø 60 | 30 |
| L | 7959 | CUCHARA ARROZ rice spoon cuillère à riz cucchiaio riso reislöffel | 1/10/50/200/1000 | 10 | 355 | 75x100 | |
| M | 6596 | CUCHARA ARROZ rice spoon cuillère à riz cucchiaio riso reislöffel | 1/10/50/200/1000 | 10 | 280 | 75x100 | 30 |
| N | 6606 | CAZO SOPA soup ladle louche à potage mestolo sopa suppenkelle | 1/10/50/200/1000 | 10 | 310 | Ø 94 | 120 |
| O | 6591 | CAZO SOPA soup ladle louche à potage mestolo sopa suppenkelle | 1/10/50/200/1000 | 10 | 265 | Ø 94 | 120 |

INOX STAINLESS STEEL 201

Pinza servir PVC
Serving PVC tong
Pince à servir pvc
Pinze da servizio pvc
Vorlegezange pvc



PVC aislante para una mejor sujeción.
PVC insulator for a better clamping.

| REF. | L(mm) | € | UE / MOQ |
|------|-------|---|----------------------|
| 2870 | 240 | | 1-24-120-480-960 / 6 |

INOX STAINLESS STEEL 201

Pinza multiusos PVC
Multiuse PVC tong
Pince multi-usage
Pinze multiuso
Mehrzweckzange



| REF. | L(mm) | € | UE / MOQ |
|------|-------|---|----------------------|
| 2871 | 240 | | 1-24-120-480-960 / 6 |
| 2872 | 300 | | 1-24-120-480-960 / 6 |
| 2873 | 350 | | 1-24-120-480-960 / 6 |

INOX STAINLESS STEEL 201

Pinza ensalada PVC
Salad PVC tong
Pince à salade pvc
Pinze per insalata pvc
Salatzange pvc



| REF. | L(mm) | € | UE / MOQ |
|------|-------|---|----------------------|
| 2867 | 240 | | 1-24-120-480-960 / 6 |

INOX STAINLESS STEEL 201

Pinza buffet PVC
Buffet PVC tong
Pince à buffet pvc
Pinze da buffet pvc
Buffetzange pvc



| REF. | L(mm) | € | UE / MOQ |
|------|-------|---|----------------------|
| 2868 | 235 | | 1-24-120-480-960 / 6 |

INOX STAINLESS STEEL 201

Pinza oval PVC
Oval PVC tong
Pince ovale pvc
Pinze ovale pvc
Ovalzange pvc



| REF. | L(mm) | € | UE / MOQ |
|------|-------|---|----------------------|
| 2869 | 240 | | 1-24-120-480-960 / 6 |

INOX STAINLESS STEEL 304

Pinza servir extra
Serving extra tong
Pince à servir extra
Pinze da servizio extra
Vorlegezange extra



| REF. | L(mm) | € | UE / MOQ |
|------|-------|---|---------------------|
| 0065 | 240 | | 0-10-25-200-400 / 6 |

INOX STAINLESS STEEL 304

Pinza repostería extra
Pastry extra tong
Pince à pâtisserie extra
Molla dolce extra
Gebäckzange extra



| REF. | L(mm) | € | UE / MOQ |
|------|-------|---|---------------------|
| 0066 | 240 | | 0-10-25-200-400 / 6 |



INOX STAINLESS STEEL 201

Pinza luxe
Luxe tong
Pince luxe
Pinze luxe
Zange luxe



Punta ondulada que asegura una mejor sujeción de los alimentos

Curled tip ensures a better fastening for the foods.

Sistema de bloqueo para mantener la pinza cerrada.

Block system to keep closed the tong.

| REF. | L(mm) | € | UE / MOQ |
|------|-------|---|----------------------|
| 2874 | 240 | | 1-24-120-480-960 / 6 |
| 2875 | 300 | | 1-24-120-480-960 / 6 |
| 2876 | 350 | | 1-24-120-480-960 / 6 |

INOX STAINLESS STEEL 304

Pinza tijera ensalada
Salad scissor tong
Pince-ciseaux à salade
Forbice insalata
Salatschere



| REF. | L(mm) | € | UE / MOQ |
|------|-------|---|---------------------|
| 3122 | 210 | | 1-0-100-200-400 / 6 |

INOX STAINLESS STEEL 201

Pinza multiusos extra
Multiuse extra tong
Pince multi-usage extra
Pinze multiuso extra
Mehrzweckzange extra



| REF. | L(mm) | € | UE / MOQ |
|------|-------|---|----------------------|
| 2877 | 240 | | 1-24-120-480-960 / 6 |
| 2878 | 300 | | 1-24-120-480-960 / 6 |
| 2879 | 350 | | 1-24-120-480-960 / 6 |

INOX STAINLESS STEEL 304

Pinza tijera tarta
Tart scissor tong
Pince-ciseaux à tarte
Forbice torta
Tortezange



| REF. | L(mm) | € | UE / MOQ |
|------|-------|---|---------------------|
| 3124 | 240 | | 1-0-100-200-400 / 6 |

INOX STAINLESS STEEL 304

Pinza tijera dulces
Cake scissor tong
Pince-ciseaux à gâteau
Forbice dolce
Kuchenzange



| REF. | L(mm) | € | UE / MOQ |
|------|-------|---|----------------------|
| 3123 | 200 | | 0-10-100-200-400 / 6 |

INOX STAINLESS STEEL 430

Pinza grill
Grill tong
Pince à grill
Pinze grill
Grillzange



| REF. | L(mm) | € | UE / MOQ |
|------|-------|---|----------------------|
| 2881 | 320 | | 1-24-120-480-960 / 6 |

INOX STAINLESS STEEL 201

Pinza ensalada muelle
Salad spring tong
Pince salade
Molla salate
Salatzange



| REF. | L(mm) | € | UE / MOQ |
|------|-------|---|----------------------|
| 5654 | 240 | | 1-0-100-800-1600 / 6 |

Buffet

Pinzas /Tongs



PVC aislante para una mejor sujeción.

PVC insulator for a better clamping.

Estas pinzas monobloc fabricadas en acero inoxidable son funcionales tanto en buffet como en cocina. Su mango de PVC en distintos colores permite controlar la contaminación cruzada de los alimentos.

These monobloc tongs in stainless steel are just as functional for service at a buffet as in the kitchen. Their distinctively coloured PVC handles makes it easy to control cross-contamination between different foods.

INOX
STAINLESS STEEL
201

PVC

3
MEDIDAS
SIZES



| REF. | COLOR | L(mm) | € | UE/MOQ |
|-------|-------|-------|---|---------------|
| 10677 | ○ | 250 | | 1-10-100 / 10 |
| 10678 | ● | 250 | | 1-10-100 / 10 |
| 10684 | ● | 250 | | 1-10-100 / 10 |
| 10685 | ● | 250 | | 1-10-100 / 10 |
| 10686 | ● | 250 | | 1-10-100 / 10 |
| 10687 | ● | 250 | | 1-10-100 / 10 |
| 10688 | ● | 250 | | 1-10-100 / 10 |
| 10701 | ○ | 300 | | 1-10-100 / 10 |
| 10702 | ● | 300 | | 1-10-100 / 10 |
| 10703 | ● | 300 | | 1-10-100 / 10 |
| 10704 | ● | 300 | | 1-10-100 / 10 |
| 10705 | ● | 300 | | 1-10-100 / 10 |
| 10706 | ● | 300 | | 1-10-100 / 10 |
| 10707 | ● | 300 | | 1-10-100 / 10 |
| 10708 | ○ | 400 | | 1-10-60 / 10 |
| 10709 | ● | 400 | | 1-10-60 / 10 |
| 10710 | ● | 400 | | 1-10-60 / 10 |
| 10711 | ● | 400 | | 1-10-60 / 10 |
| 10712 | ● | 400 | | 1-10-60 / 10 |
| 10713 | ● | 400 | | 1-10-60 / 10 |
| 10714 | ● | 400 | | 1-10-60 / 10 |



Pinza buffet
Buffet tong
Pince à buffet
Pinze buffet
Buffetzange



INOX STAINLESS STEEL 201

| REF. | L(mm) | € | UE / MOQ |
|------|-------|---|----------------------|
| 2883 | 240 | | 1-24-120-480-960 / 6 |

Pinza spaghetti
Spaghetti tong
Pince spaghetti
Molla spaghetti
Spagettizange



INOX STAINLESS STEEL 201

| REF. | L(mm) | € | UE / MOQ |
|------|-------|---|-----------------------|
| 1831 | 240 | | 1-0-100-1200-3600 / 6 |

Pinza hielo muelle inox
Spring ice tong
Pince glaçon à ressort
Molla ghiaccio
Eiswürfelzange



INOX STAINLESS STEEL 430

| REF. | L(mm) | € | UE / MOQ |
|------|-------|---|-----------------------|
| 3476 | 190 | | 1-0-102-1326-3978 / 6 |

Pinza hielo buffet
Buffet ice tong
Pince à glaçon buffet
Molla ghiaccio buffet
Eiswürfelzange buffet



INOX STAINLESS STEEL 201

| REF. | L(mm) | € | UE / MOQ |
|------|-------|---|------------------------|
| 5276 | 180 | | 1-120-480-800-2400 / 6 |

Pinza ensalada
Salad tong
Pince à salade
Pinze insalata
Salatzange



INOX STAINLESS STEEL 201

| REF. | L(mm) | € | UE / MOQ |
|------|-------|---|----------------------|
| 2882 | 240 | | 1-24-120-480-960 / 6 |

Pinza repostería extra
Extra cake tong
Pince à gâteau extra
Molla a dolce extra
Kuchenzange extra



INOX STAINLESS STEEL 201

| REF. | L(mm) | € | UE / MOQ |
|------|-------|---|---------------------|
| 2152 | 240 | | 1-0-100-60-1800 / 6 |

Pinza azúcar
Sugar tong
Pince à sucre
Molla zucchero
Zuckerzange



INOX STAINLESS STEEL 201

| REF. | L(mm) | € | UE / MOQ |
|------|-------|---|-----------------------|
| 4962 | 125 | | 1-0-250-1680-5040 / 6 |

Pinza fiambres extra
Cold meat extra tong
Pince à charcuterie extra
Molla affettati extra
Aufschnittzange extra



INOX STAINLESS STEEL 304

| REF. | L(mm) | € | UE / MOQ |
|------|-------|---|----------------------|
| 3121 | 210 | | 1-0-100-600-1800 / 6 |

Pinza pan extra
Extra bread tong
Pince à pain extra
Molla pane extra
Brotzange extra



INOX STAINLESS STEEL 201

| REF. | L(mm) | € | UE / MOQ |
|------|-------|---|---------------------|
| 3120 | 240 | | 1-0-100-200-400 / 6 |

Pinza servir
Serving tong
Pince de service
Molla arrosto
Servierzange



INOX STAINLESS STEEL 201

| REF. | L(mm) | € | UE / MOQ |
|------|-------|---|----------------------|
| 2151 | 245 | | 1-24-120-480-960 / 6 |

Pinza hielo
Ice tong
Pince à glaçon
Molla ghiaccio
Eiswürfelzange



INOX STAINLESS STEEL 201

| REF. | L(mm) | € | UE / MOQ |
|------|-------|---|-----------------------|
| 2153 | 190 | | 1-10-100-700-2800 / 6 |

Pinza hielo extra
Extra ice tong
Pince à glace extra
Pinze ghiaccio extra
Eiszange extra



INOX STAINLESS STEEL 201

| REF. | L(mm) | € | UE / MOQ |
|------|-------|---|----------------------|
| 2880 | 210 | | 1-60-120-480-960 / 6 |

CATERING

CATERING



438 AHUMADORES / SMOKERS

442 LES ESSENCES

- 444 BANDEJA GN 1/1
- 446 BANDEJA LED
- 448 BANDEJAS
- 450 ROOM SERVICE
- 451 CUBREBANDEJAS
- 452 VAJILLA PORCELANA
- 454 SET CUBERTERÍA
- 456 CUCHARAS DEGUSTACIÓN
- 458 SOPORTES
- 460 FINGER FOOD



PACK 6 BOROSILICATE

Campana ahumados sin válvula
Smoked hood without valve
Capot fumé sans valve
Cappa fumé senza valvola
Geräucherte Haube ohne Ventil

| REF. | W(mm) | L(mm) | H(mm) | Ø(mm) | € |
|-------|-------|-------|-------|-------|---|
| 11504 | 200 | 300 | 150 | 90 | |
| 11500 | 320 | 460 | 140 | 140 | |
| 11502 | 420 | 610 | 180 | 180 | |



PACK 6 BOROSILICATE

Campana ahumados con válvula
Smoked hood with valve
Capot fumé avec valve
Cappa fumé con valvola
Geräucherte Haube mit Ventil

| REF. | W(mm) | L(mm) | H(mm) | Ø(mm) | € |
|-------|-------|-------|-------|-------|---|
| 11503 | 200 | 300 | 150 | 90 | |
| 11499 | 320 | 460 | 140 | 140 | |
| 11501 | 420 | 610 | 180 | 180 | |



SERRÍN DE RAÍZ DE OLIVO / ALMENDRO

OLIVE / ALMOND ROOT SAWDUST

FRESCO FRESH

NEW

Bbq Flavour
Bbq Flavour
Bbq Flavour
Bbq Flavour
Bbq-Aroma

| REF. | PESO(kg) | € | UE / MOQ |
|-------|----------|---|-----------|
| 11977 | 0,150 | | 1-0-0-0-1 |



Envasamos según pedido para garantizar la máxima frescura y preservar todos los beneficios del producto.

We pack to order to guarantee maximum freshness and preserve all the benefits of the product.



AI ALUMINIUM M

Ahumador aromatizador profesional
Professional flavouring smoker
Fumeur d'arôme professionnel
Affumicatore per aromi professionale
Professioneller aroma smoker

| REF. | L(mm) | € |
|-------|-------|---|
| 11496 | 270 | |



AI ALUMINIUM M

Ahumador aromatizador 007 black edition
Flavourer smoker 007 black edition
Arôme fumeur 007 black edition
Aroma affumicatore 007 black edition
Aroma smoker 007 black edition

| REF. | L(mm) | € |
|-------|-------|---|
| 11510 | 220 | |



AI ALUMINIUM M

Ahumador aromatizador 007
Flavourer smoker 007
Arôme fumeur 007
Aroma affumicatore 007
Aroma smoker 007

| REF. | L(mm) | € |
|-------|-------|---|
| 11498 | 220 | |



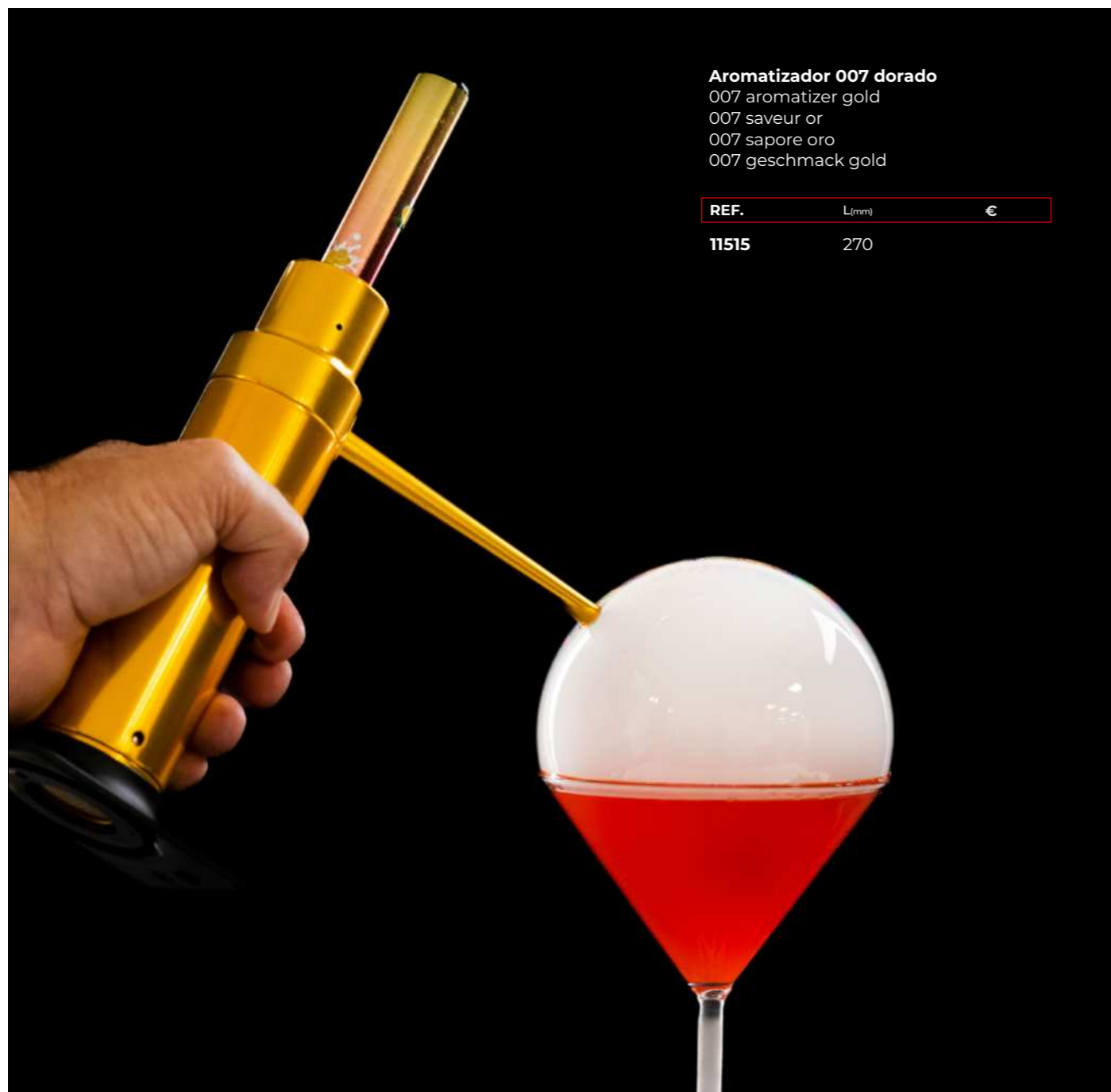

Aromatizador 007 dorado
 007 aromatizer gold
 007 saveur or
 007 sapore oro
 007 geschmack gold

| REF. | L(mm) | € |
|-------|-------|---|
| 11515 | 270 | |



Aromatizador 007 azul
 007 aromatizer blue
 007 saveur bleu
 007 sapore blu
 007 geschmack blau



| REF. | L(mm) | € |
|-------|-------|---|
| 11513 | 270 | |



Aromatizador 007 negro
 007 aromatizer black
 007 saveur noir
 007 sapore nero
 007 geschmack schwarz



| REF. | L(mm) | € |
|-------|-------|---|
| 11514 | 270 | |



Guía uso de los vaps.

Carga vapor 007 flavour VAP
 007 flavoured vapor cartridges
 007 cartouches de vapeur aromatisées
 007 cartucce di vapore al gusto
 007 aromatisierte dampfkartuschen



| REF. | AROMA | € |
|-------|-----------------------------------|---|
| 11516 | PIÑA / PINEAPPLE | |
| 11517 | ARANDANOS / BLUEBERRIES | |
| 11518 | MENTA / MINT | |
| 11519 | MANZANA VERDE / GREEN APPLE | |
| 11520 | PLATANO / BANANA | |
| 11521 | CITRONELA / LEMONGRASS | |
| 11522 | NEUTRO / NEUTRAL | |
| 11523 | CHOCOLATE CAFÉ / CHOCOLATE COFFEE | |
| 11524 | CANELA / CINNAMON | |
| 11525 | LAVANDA / LAVANDER | |
| 11527 | PURO HABANO / PURE HABANO | |

Gel pompas 007 flavour
 Gel bubbles 007 flavour
 Gel pour les bulles 007 flavour
 Gel per bolle 007 flavour
 Gel für blasen 007 flavour



| REF. | ml | € |
|-------|-----|---|
| 11628 | 200 | |



Kit campana con valvula
 Dome with valve kit
 Dôme avec kit vanne
 Cupola con kit valvola
 Dome mit ventilsatz



| REF. | € |
|-------|---|
| 11511 | |



Kit campana sin valvula
 Dome without valve kit
 Dôme sans kit vanne
 Cupola senza kit valvola
 Dome ohne ventilsatz



| REF. | € |
|-------|---|
| 11512 | |

Ahumadores Smokers

007 flavour VAP rellenable 5ml 10pcs
 007 flavored refillable 5ml 10pcs
 007 aromatisé rechargeable 5ml 10pcs
 007 aromatizzato ricaricabile 5ml 10pz
 007 aromatisiert nachfüllbar 5ml 10stk



| REF. | € |
|-------|---|
| 11526 | |

Filtros Aladin XL

Aladin filters XL
 Écrans Aladin XL
 Aladin Schermi XL
 Aladin Bildschirme XL



| REF. | Ø(mm) | € |
|-------|-------|---|
| 11497 | 25 | |

CD Aladin
 CD Aladin
 CD Aladin
 CD Aladino
 CD Aladin



| REF. | Ø(mm) | € |
|-------|-------|---|
| 11507 | 120 | |

Les Essences

Les Essences

Ahumadores / Smokers



Premio a la mejor innovación de producto.
Award for best product innovation.

Comas presenta LES ESSENCES, una colección pensada para vivir la experiencia de un catering exclusivo, con piezas de diseño, de líneas actuales, que se complementan entre ellas para crear una colección única.

Junto a profesionales del sector, hemos planteado las principales necesidades de un catering, hemos estudiado minuciosamente las formas, las medidas y las proporciones para que el conjunto sea práctico y versátil.

Cada pieza es una y múltiplo de la siguiente con lo que se consigue una perfecta disposición en sala, donde el equilibrio y la elegancia llenan el espacio, así como un fácil almacenaje tras cada pase.

Comas presents LES ESSENCES, an exclusive catering collection, with trendy pieces using modern forms, that all complement each other to form a unique collection.

Working along with professionals in the industry, we have identified the essential needs of catering and studied form, dimensions and proportion in minute detail to make the whole collection practical and versatile.

Each piece is at once single and a multiple of the next so that they can be arranged perfectly in any room and fill any space with balance and elegance and are easy to store after each service.



GN 1/1
LES ESSENCES COLLECTION



Compatible
con GN 1/1
Compatible
with GN 1/1

325 mm

530 mm



74 mm

Apilable para un mejor almacenaje. Altura máxima de tu elaboración 74mm
Stackable for easy storage. Maximum height of your workmanship 74mm

4 PASOS CON UNA SOLA BANDEJA / 4 STEPS WITH ONLY ONE TRAY

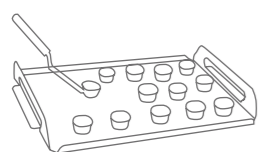

PREPARACIÓN
PREPARATION

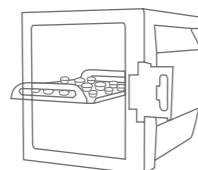

TRANSPORTE
TRANSPORT

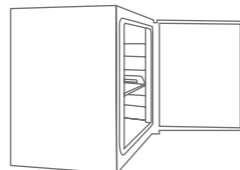

COCCIÓN
COOKING

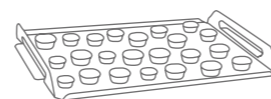

PASE
PASS



Adaptable a cajas de transporte con guías.
Adaptable to transport boxes with guides.



Adaptable a hornos industriales y carros GN.
Adaptable to industrial ovens and GN trolleys.



Conoce
la bandeja
GN 1/1

Les Essences
Bandeja GN 1/1 / GN 1/1 Tray

Aluminio ligero, facilita el transporte y soporta horneados de hasta 250 °C

Lightweight aluminium, easy to transport and withstands baking temperatures up to 250°C.

Su ancho de 325 mm encaja tanto en las guías de los hornos industriales como en las cajas de transporte GN.

Its 325 mm width fits both industrial oven rails and GN transport boxes.

Grueso de 1,5mm para una mayor resistencia.

1.5mm thick for extra strength.

Ala externa que permite almacenar las bandejas en los trolley.

External wing for storing trays on trolleys.

* Nueva altura para elaboraciones de hasta 74 mm

New height for processing of up to 74 mm

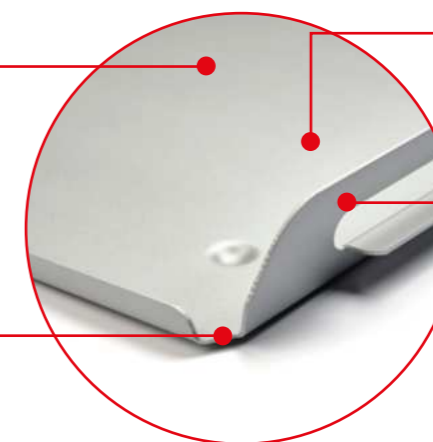

COLOR:
SILVER

COLOR:
PURE CARBON



Bandeja GN 1/1
Tray GN 1/1
Plateau silver GN 1/1
Vassoio silver GN 1/1
Silver tablett GN 1/1

| REF. | COLOR | W(mm) | L(mm) | H(mm) | € | UE / MOQ |
|-------|-------|-------|-------|-------|---|------------------|
| 11143 | ● | 325 | 530 | 74 | | 1-4-16-48-96 / 4 |
| 11144 | ● | 325 | 530 | 74 | | 1-4-16-48-96 / 4 |



Cubrebandeja silicona GN 1/1
Silicon tray cover GN 1/1
Couvercle plateau silicone GN 1/1
Coperchio vassoio in silicone GN 1/1
Tablett mit silikonbeschichtung GN 1/1

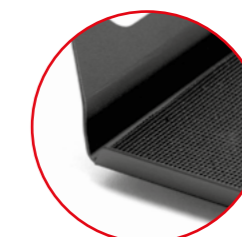

| REF. | W(mm) | L(mm) | € | UE / MOQ |
|-------|-------|-------|---|----------------|
| 10785 | 325 | 530 | | 1-4-64-0-0 / 4 |

Conoce BAHIGÜELL en la página: 510
More about BAHIGÜELL in page: 510



Luz regulable en 3 intensidades.
Light adjustable in 3 intensities.



No sumergible.
Lavable con paño húmedo.

Non-submersible.
Washable with a damp cloth.



Botón táctil de apagado y encendido.
Touch button for power on/off.



Batería recargable por USB.
USB rechargeable battery.



Patas de silicona para una mayor fijación en la superficie.
Silicone feet for a better fixation on the surface.

4h
de duración
endurance



Adaptable a bandeja GN 1/1
Compatible with GN 1/1



Base Led GN 1/1
Led board tray GN 1/1
Support led plateau GN 1/1
Supporto led per teglie GN 1/1
GN 1/1 tablett led

| REF. | W(mm) | L(mm) | € | UE / MOQ |
|-------|-------|-------|---|----------|
| 10784 | 325 | 530 | | 1-0-1/1 |

Lámina metacrilato protector.
Methacrylate protective sheet
Feuille protectrice méthacrylate
Foglio protettivo in metacrilato
Methacrylat schutzblatt

| REF. | W(mm) | L(mm) | € | UE / MOQ |
|-------|-------|-------|---|----------|
| 10808 | 325 | 530 | | 1-0-1/1 |



Lámina de metacrilato protectora.
Apto para contacto alimentario.

Protective methacrylate sheet.
Suitable for food contact.

Base LED GN 1/1.

Led tray GN 1/1.



Lámina personalizable para cualquier emplatado.

Customisable film for any dish.

Bandeja GN 1/1 Les Essences.

Tray GN 1/1 Les Essences.

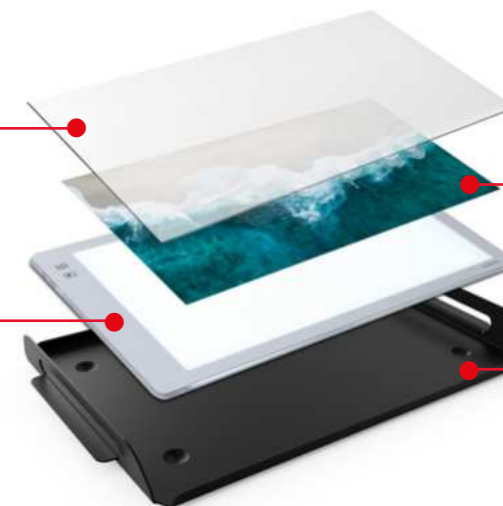

Lámina acetato personalizable
Customisable acetate film
Film acétate personnalisable
Pellicola di acetato personalizzabile
Individuell gestaltbare Acetatfolie

| REF. | W(mm) | L(mm) | MODELO | € | UE / MOQ |
|-------|-------|-------|-------------------|---|-----------|
| 10786 | 297 | 420 | A - AGUA | | 1-0-6 / 6 |
| 10799 | 297 | 420 | B - FUEGO | | 1-0-6 / 6 |
| 10800 | 297 | 420 | C - TIERRA | | 1-0-6 / 6 |
| 10801 | 297 | 420 | D - AIRE | | 1-0-6 / 6 |
| * | 297 | 420 | E - PERSONALIZADO | | 1-0-6 / 6 |

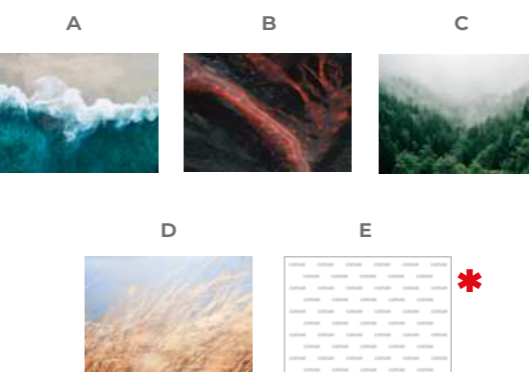
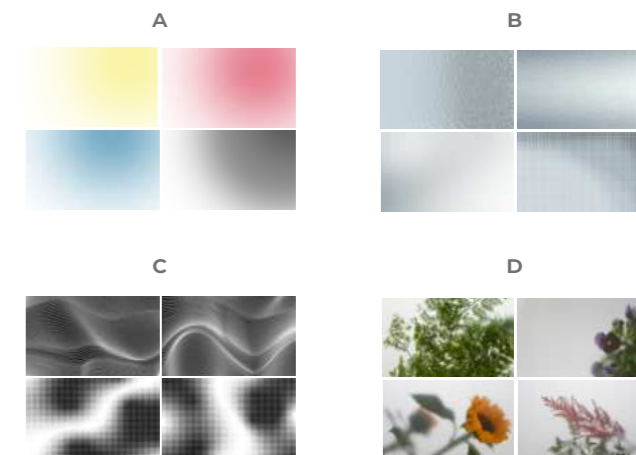

Pack 4 lámina acetato
Customisable acetate film
Film acétate personnalisable
Pellicola di acetato personalizzabile
Individuell gestaltbare Acetatfolie

| REF. | W(mm) | L(mm) | MODELO | € | UE / MOQ |
|-------|-------|-------|-----------------|---|---------------|
| 10975 | 297 | 420 | A - CHROMATIQUE | | 1-0-6-0-0 / 6 |
| 10976 | 297 | 420 | B - GLASSIER | | 1-0-6-0-0 / 6 |
| 10977 | 297 | 420 | C - KONTRAST | | 1-0-6-0-0 / 6 |
| 10978 | 297 | 420 | D - PLANTS | | 1-0-6-0-0 / 6 |



Bandeja rectangular pequeña

Catering tray
Plateau de présentation
Vassoio catering
Catering tablett



COLOR:
SOFT ARGENTO



COLOR:
PURE CARBON

| REF. | COLOR | W(mm) | L(mm) | H(mm) | € | UE / MOQ |
|------|----------------------|-------|-------|-------|---|----------------------|
| 7579 | ● | 150 | 270 | 69 | | 1-4-16-96-288 / 4 |
| 7588 | ● | 150 | 270 | 69 | | 1-4-16-96-288 / 4 |
| 7438 | SILICONA SILICONE | 145 | 265 | | | 1-4-64-1024-2048 / 4 |
| 7845 | CORCHO CORK | 145 | 265 | | | 1-4-64-360-1080 / 4 |

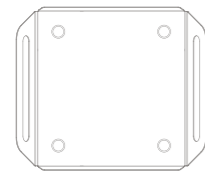

Bandeja cuadrada

Catering tray
Plateau de présentation
Vassoio catering
Catering tablett



COLOR:
SOFT ARGENTO



COLOR:
PURE CARBON

| REF. | COLOR | W(mm) | L(mm) | H(mm) | € | UE / MOQ |
|------|----------------------|-------|-------|-------|---|---------------------|
| 7581 | ● | 285 | 270 | 69 | | 1-4-16-96-192 / 4 |
| 7590 | ● | 285 | 270 | 69 | | 1-4-16-96-192 / 4 |
| 7440 | SILICONA SILICONE | 280 | 265 | | | 1-4-64-512-1536 / 4 |
| 7847 | CORCHO CORK | 280 | 265 | | | 1-4-64-360-1080 / 4 |



Asas y barandas oblicuas para facilitar el apilado.

Oblique handles and handrails facilitates easy stacking.

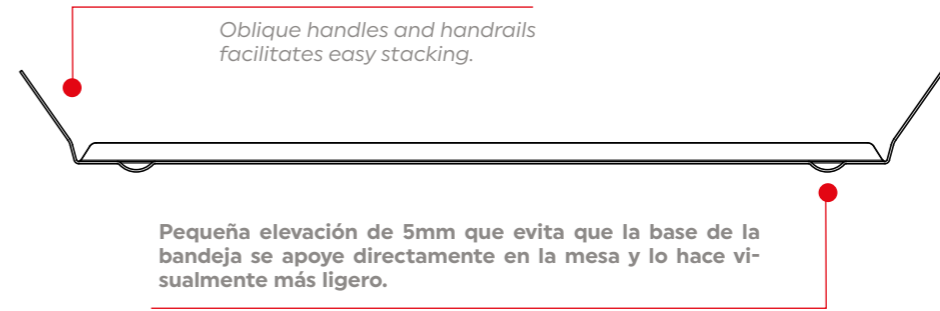

Pequeña elevación de 5mm que evita que la bandeja se apoye directamente en la mesa y lo hace visualmente más ligero.

Small elevation of 5mm avoids direct contact with the table and makes it visually lighter.



Bandeja rectangular estrecha

Catering tray
Plateau de présentation
Vassoio catering
Catering tablett



COLOR:
SOFT ARGENTO



COLOR:
PURE CARBON

| REF. | COLOR | W(mm) | L(mm) | H(mm) | € | UE / MOQ |
|------|----------------------|-------|-------|-------|---|----------------------|
| 7580 | ● | 150 | 525 | 69 | | 1-4-16-32-160 / 4 |
| 7589 | ● | 150 | 525 | 69 | | 1-4-16-32-160 / 4 |
| 7439 | SILICONA SILICONE | 145 | 520 | | | 1-4-64-1024-3072 / 4 |
| 7846 | CORCHO CORK | 145 | 520 | | | 1-4-64-360-1080 / 4 |



Bandeja rectangular grande

Catering tray
Plateau de présentation
Vassoio catering
Catering tablett



COLOR:
SOFT ARGENTO



COLOR:
PURE CARBON

| REF. | COLOR | W(mm) | L(mm) | H(mm) | € | UE / MOQ |
|------|----------------------|-------|-------|-------|---|---------------------|
| 7582 | ● | 285 | 525 | 69 | | 1-4-16-48-96 / 4 |
| 7591 | ● | 285 | 525 | 69 | | 1-4-16-48-96 / 4 |
| 7441 | SILICONA SILICONE | 280 | 520 | | | 1-4-64-512-1536 / 4 |
| 7848 | CORCHO CORK | 280 | 520 | | | 1-4-64-360-1080 / 4 |





Bandeja Room service
Room service tray
Plateau à servir
Vassoio servizio in camera
Zimmerservice tablett



| REF. | COLOR | W(mm) | L(mm) | H(mm) | € | UE / MOQ |
|------|----------------|-------|-------|-------|---|--------------------|
| 7930 | ● | 385 | 520 | 120 | | 1-4-16-48-96 / 4 |
| 7931 | CORCHO CORK | 380 | 515 | | | 1-4-64-192-336 / 4 |



Cubrebandeja silicona
Silicone tray cover
Couvercle plateau silicone
Coperchio vassoio in silicone
Tablett mit silikonbeschichtung



| REF. | W(mm) | L (mm) | Para ref. / For ref. | € | UE / MOQ |
|------|-------|--------|----------------------|---|----------------------|
| 7438 | 145 | 265 | 7579 - 7588 | | 1-4-64-1024-2048 / 4 |
| 7439 | 145 | 520 | 7580 - 7589 | | 1-4-64-1024-3072 / 4 |
| 7440 | 280 | 265 | 7581 - 7590 | | 1-4-64-512-1536 / 4 |
| 7441 | 280 | 520 | 7582 - 7591 | | 1-4-64-512-1536 / 4 |



Cubrebandeja corcho rectangular
Cork tray cover
Couvre plateau en liège
Coperchio per vassoio in sughero
Kork-auflage für tablett



| REF. | W(mm) | L (mm) | Para ref. / For ref. | € | UE / MOQ |
|------|-------|--------|----------------------|---|---------------------|
| 7845 | 145 | 265 | 7579 - 7588 | | 1-4-64-360-1080 / 4 |
| 7846 | 145 | 520 | 7580 - 7589 | | 1-4-64-360-1080 / 4 |
| 7847 | 280 | 265 | 7581 - 7590 | | 1-4-64-360-1080 / 4 |
| 7848 | 280 | 520 | 7582 - 7591 | | 1-4-64-360-1080 / 4 |
| 7931 | 380 | 515 | 7930 | | 1-4-64-192-336 / 4 |

Catering
LES ESSENCES COLLECTION



Porcelana de alta calidad fabricada en 2 tiempos de cocción a más de 1200°C, que le proporciona impermeabilidad, resistencia y suavidad al tacto.

High Quality porcelain made in 2 times firing beyond 1200°C provides impermeability, resistance and soft touch.



Les Essences

Vajilla porcelana / Porcelain tableware

Versatilidad, composición, orden, apilabilidad, practicidad... El sistema modular de la vajilla LES ESSENCES, facilita el trabajo de un servicio de catering.

Versatility, composition, order, stackability, practicality... The modular system LES ESSENCES, facilitates the work in a catering service.

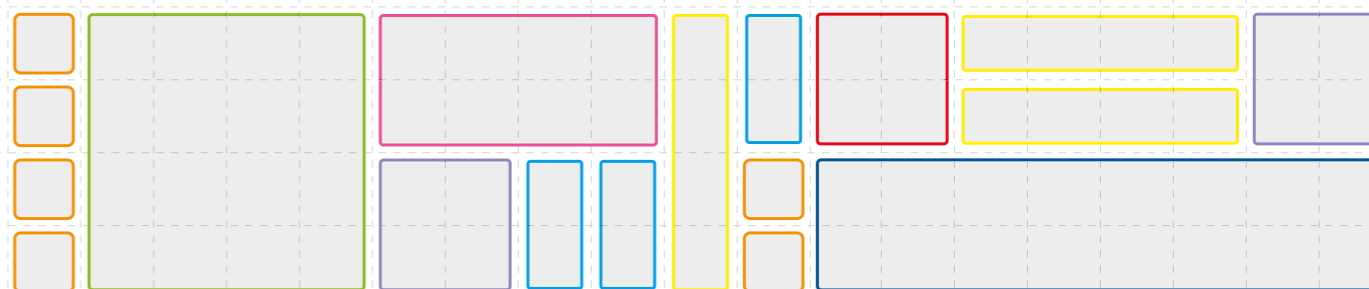

Plato postre
Dessert plate
Assiette à dessert
Piatto dolce
Dessert platte



| REF. | W(mm) | L(mm) | H(mm) | € | UE / MOQ |
|------|-------|-------|-------|---|---------------------|
| 7681 | 120 | 120 | 18 | | 1-4-64-360-1080 / 4 |



Barquillo
Wafer
Barquette
Vassoietto fondo
Waffel



| REF. | W(mm) | L(mm) | H(mm) | € | UE / MOQ |
|------|-------|-------|-------|---|---------------------|
| 7680 | 60 | 240 | 18 | | 1-4-64-360-1080 / 4 |



Plato Half
Half Dessert Plate
Assiette
Dessert Half
Piatto Dolce Half
Dessertteller Half



| REF. | W(mm) | L(mm) | H(mm) | € | UE / MOQ |
|-------|-------|-------|-------|---|-----------------|
| 11972 | 60 | 120 | 18 | | 0-6-144-0-0 / 6 |



Plato llano
Dinner plate
Assiette plate
Piatto piano
Teller



| REF. | W(mm) | L(mm) | H(mm) | € | UE / MOQ |
|------|-------|-------|-------|---|---------------------|
| 7672 | 240 | 240 | 13 | | 1-4-24-360-1080 / 4 |



Bandeja simple
Simple tray
Plateau simple
Vassoio semplice
Tablett



| REF. | W(mm) | L(mm) | H(mm) | € | UE / MOQ |
|------|-------|-------|-------|---|---------------------|
| 7671 | 120 | 240 | 15 | | 1-4-48-360-1080 / 4 |



Vaso
Cup
Verre
Bicchiere
Becher



| REF. | W(mm) | L(mm) | H(mm) | ml | € | UE / MOQ |
|------|-------|-------|-------|----|---|---------------------|
| 7679 | 60 | 60 | 60 | 70 | | 1-4-72-360-1080 / 4 |



Bol
Bowl
Bol
Ciotola
Quadratische schale



| REF. | W(mm) | L(mm) | H(mm) | ml | € | UE / MOQ |
|------|-------|-------|-------|-----|---|---------------------|
| 7670 | 120 | 120 | 60 | 400 | | 1-4-48-360-1080 / 4 |



Bandeja doble
Double tray
Plateau double
Vassoio doppio
Doppeltes tablett



| REF. | W(mm) | L(mm) | H(mm) | € | UE / MOQ |
|------|-------|-------|-------|---|---------------------|
| 7673 | 120 | 480 | 13 | | 1-4-24-360-1080 / 4 |



PACKAGING
CUSTOM BOX



Cuchillo Vintage
Vintage Knife
Couteau Vintage
Coltello Vintage
Vintage-Messer

Tenedor Vintage
Vintage Fork
Fourchette Vintage
Forchetta Vintage
Vintage-Gabel

| REF. | L(mm) | € | UE / MOQ |
|-------|-------|---|-------------------|
| 11662 | 115 | | 0-12-120-0-0 / 12 |

| REF. | L(mm) | € | UE / MOQ |
|-------|-------|---|-------------------|
| 11663 | 117 | | 0-12-120-0-0 / 12 |

Tenedor Mini Vintage
Vintage Mini Fork
Fourchette Mini Vintage
Forchetta Mini Vintage
Mini-Vintage-Gabel



Pincho Vintage
Vintage Skewer
Brochette Vintage
Set Da Aperitivo Vintage
Vintage-Spiess



| REF. | L(mm) | € | UE / MOQ |
|-------|-------|---|-------------------|
| 11664 | 72 | | 0-12-120-0-0 / 12 |

| REF. | L(mm) | € | UE / MOQ |
|-------|-------|---|-------------------|
| 11665 | 104 | | 0-12-120-0-0 / 12 |

Soporte Cubiertos Individual
Cutlery Rest Individual
Support-Couverts Individuel
Supporto Posate Individuale
Besteckhalter Einzeln



Soporte Cubiertos Triple
Cutlery Rest Triple
Support-Couverts Triple
Supporto Posate Triplo
Besteckhalter Mit Drei Fächern



| REF. | W(mm) | L(mm) | H(mm) | € | UE / MOQ |
|-------|-------|-------|-------|---|-------------------|
| 11667 | 60 | 54 | 15 | | 0-12-240-0-0 / 12 |

| REF. | W(mm) | L(mm) | H(mm) | € | UE / MOQ |
|-------|-------|-------|-------|---|----------------|
| 11666 | 60 | 145 | 15 | | 0-4-80-0-0 / 4 |



Diseño especialmente pensado para la degustación de aperitivos rápidos durante un catering.

Designed specially to tasting snacks during a catering.



Descubre más.



Les Essences

Cucharas degustación / Tasting spoons



Cuchara arrastre
Drag spoon
Cuillère à glisser
Cucchiaio drag
Drag-probierlöffel

| REF. | COLOR | L(mm) | € | UE / MOQ |
|------|--------------------------|-------|---|--------------------------|
| 7568 | PERFORADA VINTAGE | 75 | | 0-12-120-3960-15840 / 12 |
| 7569 | VINTAGE | 75 | | 0-12-120-3960-15840 / 12 |
| 7570 | VINTAGE PVD INTENSE GOLD | 75 | | 0-12-120-3960-15840 / 12 |
| 7571 | VINTAGE PVD PURE CARBON | 75 | | 0-12-120-3960-15840 / 12 |



Cuchara acompañamiento
Accompaniment spoon
Cuillère d'accompagnement
Cucchiaio per accompagnamento
Begleitung probierlöffel

| REF. | COLOR | L(mm) | € | UE / MOQ |
|------|--------------------------|-------|---|--------------------------|
| 7564 | PERFORADA VINTAGE | 120 | | 0-12-120-3960-15840 / 12 |
| 7565 | VINTAGE | 120 | | 0-12-120-3960-15840 / 12 |
| 7566 | VINTAGE PVD INTENSE GOLD | 120 | | 0-12-120-3960-15840 / 12 |
| 7567 | VINTAGE PVD PURE CARBON | 120 | | 0-12-120-3960-15840 / 12 |



Cuchara aperitivos de montaje
Appetizer assembly spoon
Assemblage du cuillères apéritif
Assemblaggio cucchiaio antipasto
Probierlöffel-montage-vorspeise

| REF. | COLOR | L(mm) | € | UE / MOQ |
|------|--------------------------|-------|---|--------------------------|
| 7572 | PERFORADA VINTAGE | 71 | | 0-12-120-3960-15840 / 12 |
| 7573 | VINTAGE | 71 | | 0-12-120-3960-15840 / 12 |
| 7574 | VINTAGE PVD INTENSE GOLD | 71 | | 0-12-120-3960-15840 / 12 |
| 7575 | VINTAGE PVD PURE CARBON | 71 | | 0-12-120-3960-15840 / 12 |



Cuchara aperitivos de montaje plana
Flat appetizer assembly spoon
Cuillère plate pour assablage
Cucchiaio piatto per antipasti da assemblato
Flacher snacklöffel

| REF. | COLOR | L(mm) | € | UE / MOQ |
|------|--------------------------|-------|---|--------------------------|
| 7576 | VINTAGE | 85 | | 0-12-120-3960-15840 / 12 |
| 7577 | VINTAGE PVD INTENSE GOLD | 85 | | 0-12-120-3960-15840 / 12 |
| 7578 | VINTAGE PVD PURE CARBON | 85 | | 0-12-120-3960-15840 / 12 |



Soporte conos
Cones support
Support cornets
Supporto per coni finger food
Auflage für kegel



| REF. | COLOR | W(mm) | L(mm) | H(mm) | € | UE / MOQ |
|------|-------|-------|-------|-------|---|--------------------|
| 7586 | ● | 120 | 240 | 40 | | 1-4-16-192-336 / 4 |
| 7595 | ● | 120 | 240 | 40 | | 1-4-16-192-336 / 4 |



Soporte piruletas
Lollipops support
Support sucettes
Supporto spiedini finger food
Display für lollies



| REF. | COLOR | W(mm) | L(mm) | H(mm) | € | UE / MOQ |
|------|-------|-------|-------|-------|---|--------------------|
| 7585 | ● | 120 | 240 | 40 | | 1-4-16-192-336 / 4 |
| 7594 | ● | 120 | 240 | 40 | | 1-4-16-192-336 / 4 |



Bandeja madera roble
Oak wood tray
Plateau en chêne
Vassoio legno quercia
Eichenholz tablett



Se vende por separado.
Sold separately.

| REF. | W(mm) | L(mm) | H(mm) | € | UE / MOQ |
|------|-------|-------|-------|---|--------------------|
| 7587 | 120 | 240 | 10 | | 1-4-16-192-512 / 4 |



PACKAGING
CUSTOM BOX



Soporte para tacos
Tacos support
Plat support à tacos
Supporto per tacos
Auflage für tacos



| REF. | COLOR | W(mm) | L(mm) | H(mm) | € | UE / MOQ |
|------|-------|-------|-------|-------|---|--------------------|
| 7583 | ● | 120 | 240 | 40 | | 1-4-16-192-512 / 4 |
| 7592 | ● | 120 | 240 | 40 | | 1-4-16-192-512 / 4 |



Soporte para brochetas
Skewers support
Support brochette
Supporto per spiedini lunghi
Spießhalter



| REF. | COLOR | W(mm) | L(mm) | H(mm) | € | UE / MOQ |
|------|-------|-------|-------|-------|---|---------------------|
| 7584 | ● | 60 | 240 | 30 | | 1-4-16-320-1280 / 4 |
| 7593 | ● | 60 | 240 | 30 | | 1-4-16-320-1280 / 4 |



PACKAGING
CUSTOM BOX

El término "finger food" se refiere a alimentos que se pueden consumir con las manos, sin la necesidad de cubiertos. Estos platillos suelen ser pequeños, fáciles de comer y están diseñados para ser saboreados en una o dos mordidas.

Siguiendo este concepto, Comas ha creado una colección de cubiertos de tamaño reducido, como una prolongación de nuestros dedos, que permiten disfrutar de estos platillos de manera práctica y original, ideales para caterings y eventos.

The term "finger food" refers to food that can be eaten with the hands, without the need for cutlery. These dishes are usually small, easy to eat and designed to be savoured in one or two bites.

Following this concept, Comas has created a collection of small-sized cutlery, like an extension of our fingers, which allows us to enjoy these dishes in a practical and original way.



Finger Food

INOX Nickel Free 18% / 2mm / Vintage



PACKAGING
CUSTOM BOX

MINI CUBIERTOS PARA EXPERIENCIAS DE GRAN SABOR BIG TASTE EXPERIENCES MINI CUTLERY



Cubertería de diseño propio creada para comidas de servicio rápido.
Own design cutlery created for fast-service meals.

INOX
STAINLESS
STEEL
430

- A **8784** CUCHILLO LUNCH
cake knife, couteau gâteau, coltello dolce, kuchenmesser
- B **8786** CUCHARA CAFÉ
tea spoon, cuillère café, cucchiaio caffè, kaffeelöffel
- C **8785** TENEDOR LUNCH
cake fork, fourchette gâteau, forchetta dolce, kuchengabel
- D **8787** PINCHO TAPAS
cocktail stick, stick à cocktail, spiedo, spieß
- 8795** PACK 4 PCS
pack 4 pieces, pack 4 pièces, pack 4 pz., 4 pack

| UE | MOQ | ✂ mm | ✂ mm |
|---------------------|-----|------|------|
| 0/12/120/2520/15120 | 24 | 140 | 6 |
| 0/12/120/2520/15120 | 24 | 130 | 2 |
| 0/12/120/2520/15120 | 24 | 130 | 2 |
| 0/12/120/2520/15120 | 24 | 137 | 2 |
| 1/24/96/576/2880 | 24 | | |

INOX
STAINLESS
STEEL
430



1001 Black

INOX Nickel Free 18% / 1mm / PVD

- A **1746** TENEDOR MINI LUNCH
mini cake fork, fourchette minigâteau, forchetta mini dolce, kuchengabel klein
- B **1747** CUCHARA MOKA
coffee/moka spoon, cuillère moka, cucchiaio moka, mokkalöffel

| UE | MOQ | ✂ mm | ✂ mm |
|----------------------|-----|------|------|
| 0/12/600/25200/75600 | 120 | 110 | 1 |
| 0/12/600/25200/75600 | 120 | 110 | 1 |



LES ESSENCES
 CATERING LINE



lab
 SERIES



CALIU

Comas apuesta por crear un sistema eficiente de servicio y presentación tanto en sala, catering o buffet.

Los diseños modulares y complementarios entre sí de las colecciones Les Essences, Lab y Caliu elevan la experiencia del cliente mediante presentaciones más atractivas pudiendo combinar colores, materiales y composición, creando una coherencia visual.

Al personal de hostelería le permite mejorar la eficiencia operativa lo que se traduce en una reducción de tiempos de preparación, desmontaje y almacenaje.

Comas is committed to creating an efficient system of service and presentation in the dining room, catering or buffet.

The modular and complementary designs of the Les Essences, Lab and Caliu collections enhance the customer experience through more attractive presentations by combining colours, materials and composition, creating visual coherence.

It allows catering staff to improve operational efficiency, which translates into reduced preparation, dismantling and storage times.

BRASA

GRILL



466 CALIU

- 466 BBQ
- 468 ACCESORIOS
- 470 PARRILLAS
- 472 ROBATA YAKI
- 474 KITS

476 BRASA / EMBER

- 476 IGNIS
- 478 KASAI
- 480 LLAUNES
- 482 PLATO PIEDRA
- 484 PLATO HIERRO FUNDIDO
- 486 ACCESORIOS
- 488 CARBÓN



Descubre
el catálogo
de brasa.

BARBACOA CALIU

Las barbacoas de sobremesa Caliu destacan por su diseño único y minimalista pero también por su versatilidad para trabajar múltiples técnicas y cocciones. El embellecedor reversible te permite elegir dos alturas diferentes con las que cocinar.

CALIU BARBACUE

Caliu tabletop barbecues stand out for their unique and minimalist design and their versatility to multiple cooking methods and techniques. With the convertible outer house, you may choose between two different cooking heights.

Sin ensamblajes ni partes móviles, producida con pocas piezas para obtener un resultado robusto y duradero.

No assemblies or moving parts, produced with few parts for a robust and durable result.

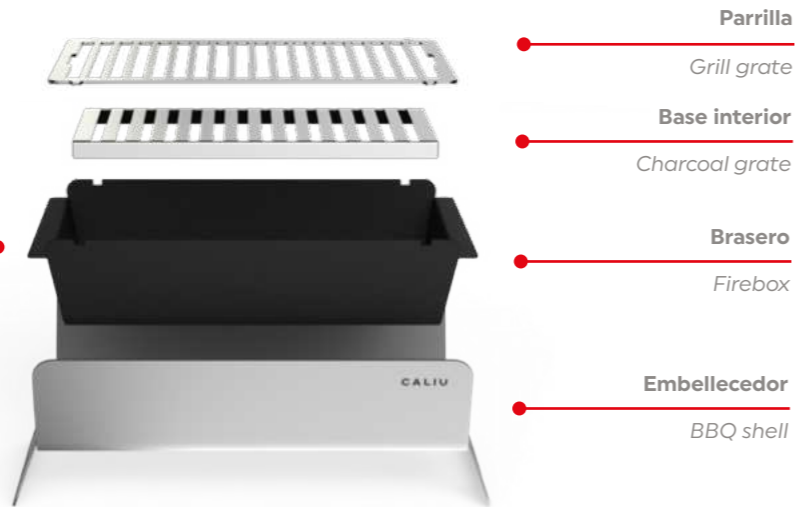

Versátil, modular, ligera, confeccionada íntegramente en acero inoxidable y provista de todos los accesorios necesarios, adaptándose sin problemas a cualquier entorno.

Versatile, modular, lightweight, crafted entirely from stainless steel, and equipped with all necessary accessories, it seamlessly adapts to any environment.



Discover Caliu's World



PARRILLA



ESTRUCTURA

Caliu
BBQ / BBQ



BBQ Caliu Horeca

| REF. | W(mm) | L(mm) | H(mm) | € | UE / MOQ |
|------|-------|-------|-------|---|----------------|
| 8500 | 299 | 452 | 160 | | 1-0-1-6-18 / 1 |



BBQ Caliu Catering

| REF. | W(mm) | L(mm) | H(mm) | € | UE / MOQ |
|------|-------|-------|-------|---|----------------|
| 8684 | 299,5 | 859 | 160 | | 1-0-1-6-18 / 1 |



CALIU ACCESORIOS

Mejora tus habilidades a la brasa con los accesorios adecuados, desde dispositivos experimentales hasta elementos esenciales clásicos. Con las herramientas adecuadas, como la tapa que transforma tu barbacoa en un horno, el mango multitarea, la chimenea para encender el carbón rápidamente...

INOX STAINLESS STEEL 430

Tapa BBQ
Bbq lid
Couvercle du bbq
Coperchio del bbq
Grilldeckel



Efecto horno, potencia los aromas.
Oven effect, enhances the aromas.



| REF. | W(mm) | L(mm) | H(mm) | € | UE / MOQ |
|------|-------|-------|-------|---|-----------------|
| 9969 | 260 | 366,2 | 140 | | 1-0-4-24-72 / 1 |

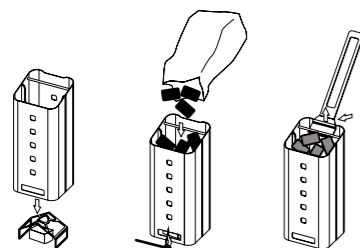

La chimenea Caliu es la mejor herramienta para encender el carbón de forma rápida, limpia y segura, en 20 minutos estará listo para empezar a cocinar.

In just 20 minutes, you'll be able to start cooking thanks to the Caliu Chimney's ability to ignite coal fast, cleanly, and safely.

INOX STAINLESS STEEL 430

Chimenea BBQ
Chimney BBQ
Cheminée BBQ
Grigliato camino BBQ
BBQ kamin



| REF. | W(mm) | L(mm) | H(mm) | € | UE / MOQ |
|------|-------|-------|-------|---|------------------|
| 8686 | 80 | 125 | 300 | | 1-0-4-68-128 / 1 |

SILICONE



Cubrebandeja silicona GN 1/1
Silicon tray cover GN 1/1
Couvercle plateau silicone GN 1/1
Coperchio vassoio in silicone GN 1/1
Tablett mit silikonbeschichtung GN 1/1



| REF. | W(mm) | L(mm) | € | UE / MOQ |
|-------|-------|-------|---|----------------|
| 10785 | 325 | 530 | | 1-4-64-0-0 / 4 |

INOX STAINLESS STEEL 430

Pinza BBQ
Bbq tong
Pince bbq
Molla bbq
Zange bbq



| REF. | W(mm) | L(mm) | € | UE / MOQ |
|------|-------|-------|---|----------------------|
| 8687 | 55 | 260 | | 1-0-48-5765-1728 / 1 |



INOX STAINLESS STEEL 304

INOX STAINLESS STEEL 430

PARRILLA ESTRUCTURA



Plato brasa
Bbq plate
Assiette bbq
Piatto bbq
Grillplate

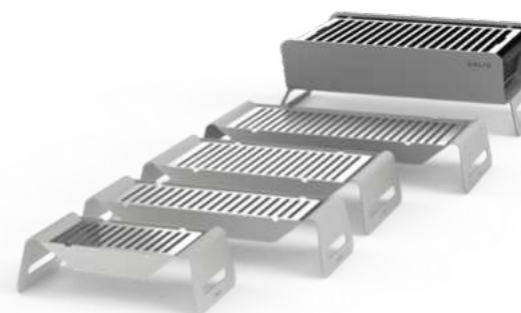

| REF. | W(mm) | L(mm) | H(mm) | € | UE / MOQ |
|-----------------|-------|-------|-------|---|------------------|
| S 8181 | 137,5 | 253 | 82 | | 1-0-4-56-224 / 1 |
| M 8685 | 137,5 | 354 | 82 | | 1-0-4-56-168 / 1 |
| L 11484 | 212,5 | 354 | 82 | | 1-0-4-0-0 / 1 |
| XL 11485 | 442 | 212,5 | 82 | | 1-0-4-0-0 / 1 |

S
Aperitivo / Side

M
Degustación / Tasting

L
Principal / Main

XL
Compartir / Sharing

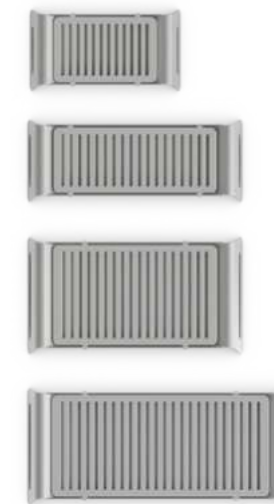

Recambio parrilla
Inox grill bbq spare part
Pièce de rechange inox gril bbq
Ricambio inox griglia bbq
Inox grill grillplate ersatzteil

| REF. | W(mm) | L(mm) | H(mm) | € | UE / MOQ |
|-----------------|-------|-------|-------|---|---------------|
| S 11489 | 121 | 171 | | | 1-0-0-0-0 / 1 |
| M 11490 | 121 | 272 | | | 1-0-0-0-0 / 1 |
| L 11491 | 196 | 272 | | | 1-0-0-0-0 / 1 |
| XL 11492 | 198 | 360 | | | 1-0-0-0-0 / 1 |

Base interior plato brasa
Interior base for grilled plate
Base intérieure pour plaque grillée
Base interna per piastra grigliata
Innensockel für grillplatte

| REF. | W(mm) | L(mm) | H(mm) | € | UE / MOQ |
|-----------------|-------|-------|-------|---|---------------|
| S 11578 | 95 | 85 | 10 | | 1-0-0-0-0 / 1 |
| M 11579 | 95 | 186 | 10 | | 1-0-0-0-0 / 1 |
| L 11580 | 170 | 186 | 10 | | 1-0-0-0-0 / 1 |
| XL 11581 | 170 | 274 | 10 | | 1-0-0-0-0 / 1 |

PARRILLAS CALIU

Conviértete en un experto de la brasa con las parrillas Caliu, gracias a sus materiales de alta calidad. Estas parrillas proporcionan un rendimiento excepcional y una gran durabilidad, lo que las hace ideales para conseguir el sellado perfecto o añadir un sabor extra a tus alimentos.

CALIU GRATES

Caliu's grates will turn you into a grill master, delivering unbeatable flavor through various techniques and high-quality materials. These grates provide exceptional performance and durability, ideal for achieving the perfect sear or adding extra flavor to your food.

Parrilla de marcaje. Parrilla de hierro fundido. Ideal para lograr un marcado bien definido.

Marking Grate. Cast Iron Grate. Ideal for achieving sear marks.

Plancha CALIU. Una superficie de cocción versátil, eficiente y duradera.

CALIU Griddle. A versatile, efficient and durable cooking surface.



Parrilla YAKI. Malla inoxidable. Perfecta para cocinar una amplia gama de alimentos.

YAKI Grate. Stainless steel mesh. Perfect for grilling a wide range of foods.

Parrilla CALIU (estándar). Alta calidad, resistente al óxido y a la corrosión, fácil de limpiar y mantener.

CALIU Grate (standard). High quality, rust and corrosion-resistant, easy to clean and maintain.

* Todas las parrillas son compatibles con el mango CALIU. / All grates are compatible with the CALIU handle.



Discover Caliu's World



INOX STAINLESS STEEL 304

Recambio parrilla inox BBQ Caliu
Inox grill caliu bbq
Pièce de rechange inox grill caliu bbq
Ricambio inox griglia caliu bbq
Inox caliu grill grillplate ersatzteil

| REF. | W(mm) | L(mm) | H(mm) | € | UE / MOQ |
|-------|-------|-------|-------|---|-------------|
| 11495 | 268 | 363 | 3 | | 1-0-0-0-0/1 |



CAST IRON

Parrilla hierro fundido
Cast iron grill
Fonte grill
Chisa griglia
Gusseisen grill

| REF. | W(mm) | L(mm) | H(mm) | € | UE / MOQ |
|-------|-------|-------|-------|---|-------------|
| 11487 | 268 | 363 | 10 | | 1-0-0-0-0/1 |

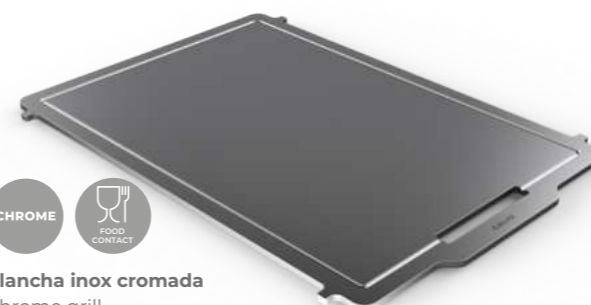

CHROME FOOD CONTACT

Plancha inox cromada
Chrome grill
Chromée grill
Cromata griglia
Chromeplatte

| REF. | W(mm) | L(mm) | H(mm) | € | UE / MOQ |
|-------|-------|-------|-------|---|-------------|
| 11486 | 267 | 373 | 5 | | 1-0-0-0-0/1 |

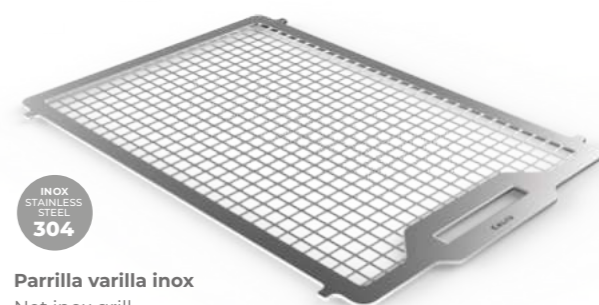

INOX STAINLESS STEEL 304

Parrilla varilla inox
Net inox grill
inox filet grill
inox griglia netta
inox netz grill

| REF. | W(mm) | L(mm) | H(mm) | € | UE / MOQ |
|-------|-------|-------|-------|---|-------------|
| 11488 | 267 | 373 | 3 | | 1-0-0-0-0/1 |

INOX STAINLESS STEEL 304

Pack 6 brocheta inox
Inox skewer
Inox brochette
Inox spiedo
Inox spieß

| REF. | L(mm) | € | UE / MOQ |
|-------|-------|---|-------------|
| 11493 | 35 | | 1-0-0-0-0/1 |
| 11494 | 20 | | 1-0-0-0-0/1 |



PACK 6

INOX STAINLESS STEEL 430

Recambio rejilla base interior bbq caliu
Inner base caliu horeca bbq
base intérieure caliu horeca bbq
base interna caliu horeca bbq
innere basis caliu horeca bbq

| REF. | W(mm) | L(mm) | H(mm) | € | UE / MOQ |
|------|-------|-------|-------|---|-------------|
| 5126 | 178 | 335 | 1,5 | | 1-0-0-0-0/1 |



El accesorio perfecto para los chefs profesionales que permite convertir la barbacoa en una estación de brasa para catering, con la capacidad de trabajar por capas en distintas alturas y maximizar la producción.

The perfect accessory for professional chefs to convert the barbecue into a catering grill station, with the ability to work in layers at different heights and maximise production. It offers a more versatile and efficient cooking experience.



Discover
Caliu's
World

INOX
STAINLESS
STEEL
430

Caliu
ROBATAYAKI

Combina con recipientes 1/3, 1/6 y 1/9 GN.

Combines with 1/3, 1/6 and 1/9 GN.

Combina con Pinchos Touché, ver p. 495

Combines Touché Skewer, see p. 495

Combina con Llaunes COMAS, ver p. 510

Combines with Llaunes COMAS, see p. 510

Combina con todas las parrillas CALIU, ver p. 495

Combines with all CALIU grates, see p. 495



NO INCLUYE: BBQ Caliu catering
NOT INCLUDED: BBQ Caliu catering



Robata grill YAKI

| REF. | W(mm) | L(mm) | H(mm) | KG | € | UE / MOQ |
|-------|-------|-------|-------|----|---|---------------|
| 10957 | 295 | 812 | 430 | 14 | | 1-0-0-0-0 / 1 |

Con el Yaki, tendrás la libertad de cocinar de diversas maneras gracias a su diseño innovador y versátil.

Se compone de barras móviles que se colocan en las ranuras laterales de la barbacoa, lo que permite ajustar fácilmente la altura de la parrilla. Son ideales para Cubetes GN de 1/4 y 1/6, lo que te permite mantener salsas o guarniciones calientes y emplatar directamente.

Recambio barras móviles Robata Yaki

Spare Robata Yaki mobile bars
Pièce de rechange barre amovible
Ricambio barra estraibile
Abnehmbares ersatzteil für die stange

| REF. | PCS | € | UE / MOQ |
|-------|-----|---|---------------|
| 11066 | 2 | | 1-0-0-0-0 / 1 |

Recambio bandeja superior Robata Yaki

Replacement top tray Robata Yaki
Pièce de rechange étagère
Ricambio mensola
Regal ersatzteil

| REF. | PCS | € | UE / MOQ |
|-------|-----|---|---------------|
| 11482 | 1 | | 1-0-0-0-0 / 1 |

With the Yaki, you have the freedom to cook in a variety of ways thanks to its innovative and versatile design.

It consists of movable bars that are placed in the side slots of the barbecue, allowing you to easily adjust the height of the grill. They are ideal for 1/4 and 1/6 GN tubs, allowing you to keep sauces or side dishes hot and plate them directly.



PACKAGING
CUSTOM BOX

Caliu es la marca de conceptos gastronómicos creada hace 10 años por bahígüell, una agencia de diseño de producto de Girona. 'Creemos que los detalles importan, por eso cuidamos cada fase del diseño y funcionalidad, desde el primer boceto de la fase conceptual hasta el acabado final del producto'. -bahígüell.

The gastronomic concepts brand Caliu was created 10 years ago by the product design agency bahígüell, based in Girona. 'We believe that details matter, that's why we take care of every phase of design and functionality, from the first sketch in the conceptual phase to the final product finish'. -bahígüell.



KIT CALIU 1. ESSENTIAL

BBQ Caliu + Pinza + Chimenea
BBQ Caliu + Tong + Chimney

| REF. | € | UE / MOQ |
|------|---|---------------|
| 8182 | | 1-0-1-0-0 / 1 |

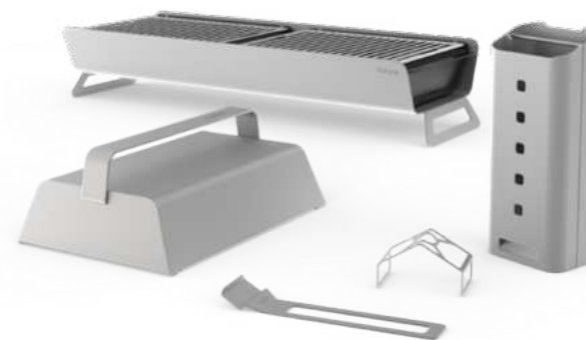

KIT CALIU 3. CATERING PREMIUM

BBQ Caliu Catering + Tapa + Pinza + Chimenea
BBQ Caliu Catering + Lid + Tong + Chimney

| REF. | € | UE / MOQ |
|-------|---|---------------|
| 11626 | | 1-0-1-0-0 / 1 |



KIT CALIU 2. PREMIUM

BBQ Caliu + Tapa + Pinza + Chimenea
BBQ Caliu + Lid + Tong + Chimney

| REF. | € | UE / MOQ |
|------|---|---------------|
| 8183 | | 1-0-1-0-0 / 1 |



KIT CALIU 4. ROBATA YAKI

BBQ Caliu Catering + Robata Yaki + Pinza + Chimenea
BBQ Caliu Catering + Robata Yaki + Tong + Chimney

| REF. | € | UE / MOQ |
|-------|---|---------------|
| 11627 | | 1-0-1-0-0 / 1 |



PACKAGING
CUSTOM BOX

NEW



APTA PARA
LEÑA Y CARBÓN

Ignis

Bbq hierro fundido Cast iron bbq

La grasa no se acumula en la plancha, lo que garantiza un punto de cocción perfecto.

Fat does not accumulate on the griddle, which guarantees a perfect cooking point.

Diseño de parrilla circular, fundida en una sola pieza, con mucha superficie operativa.

Circular grill design, cast in one piece, with a large operating surface.

Estructura de hierro fundido de alta calidad.

High quality cast iron structure.

Parrilla con salidas de aire ajustables que permiten el control preciso del calor para adaptarse a las diferentes necesidades del cocinado.

Grill with adjustable air vents that allow precise heat control to suit different cooking needs.

Recubierto con aceite vegetal, le proporciona antiadherencia a la superficie.

Coated with vegetable oil, it provides non-stick surface.

Excelente retención y distribución del calor.

Excellent heat retention and heat distribution.

Espacio para almacenar leña o carbón.

Space for storing firewood or charcoal.

4 ruedas pivotantes, 2 de ellas con freno.

4 swivel castors, 2 of them with brakes.

Disco de HIERRO FUNDIDO
CAST IRON Disc



INCLUYE ARO ELEVADOR
ELEVATOR RING INCLUDED



INCLUYE PRENSA PARA CARNE
MEAT PRESS INCLUDED

Bbq Disco Hierro Colado C/Cajon Cenizas
Bbq Cast Iron Disc With Ash Draw
Bbq Disque En Fonte Avec Tiroir À Cendres
Bbq Disco In Ghisa/ Cassetto Ceneri
Bbq Drehscheibe Gusseisen M. Aschekiste

| REF. | PESO(kg) | € | UE / MOQ |
|-------|----------|---|---------------|
| 11978 | 10 | | 0-0-1-0-0 / 1 |



Conoce
Ignis.

Una barbacoa de ladrillo refractario es una excelente opción para quienes desean una estructura duradera y resistente para cocinar a la parrilla al aire libre. La capacidad aislante del material refractario permite una mayor eficiencia calorífica.

A refractory brick barbecue is an excellent choice for those who want a durable and resistant structure for outdoor grilling. The insulating capacity of the refractory material allows for greater heat efficiency.

MATERIAL DURADERO: Resistente al calor y a las altas temperaturas. Soporta cocciones sin agrietarse ni deformarse con facilidad.



DURABLE MATERIAL: Resistant to heat and high temperatures. Withstands cooking without cracking or deforming easily.

BUENA RETENCIÓN DEL CALOR: El ladrillo refractario tiene la capacidad de retener el calor de manera eficiente, lo que te permite cocinar de forma uniforme y mantener la temperatura deseada durante más tiempo.



GOOD HEAT RETENTION: The refractory brick has the ability to retain heat efficiently, allowing you to cook evenly and maintain the desired temperature for longer.

OPCIÓN SEGURA: El ladrillo refractario no emite sustancias tóxicas ni partículas dañinas cuando se calienta, lo que lo convierte en una opción segura para cocinar alimentos.



SAFE CHOICE: The refractory brick doesn't emit toxic substances or harmful particles when heated, making it a safe choice for cooking food.

Parrilla de cocción.
Cooking mesh.

Asas de acero inoxidable.
Stainless steel handles.

Vermiculita.
Vermiculite.

Ranuras de ventilación deslizantes.
Sliding air vents.



Ladrillo refractario.
Fire brick.

Acero inoxidable cepillado.
Brushed stainless steel.



Conoce Kasai.

Kasai
BBQ

INOX STAINLESS STEEL
430

Barbacoa KASAI
KASAI BBQ



| REF. | W(mm) | L(mm) | H(mm) | MODELO | € | UE / MOQ |
|-------|-------|-------|-------|--------|---|----------------|
| 11121 | 230 | 310 | 165 | NANO | | 1-0-1-4-16 / 1 |
| 11122 | 265 | 405 | 210 | SMALL | | 1-0-1-4-16 / 1 |
| 11123 | 355 | 465 | 210 | MEDIUM | | 1-0-1-4-16 / 1 |
| 11124 | 260 | 700 | 210 | LARGE | | 1-0-1-4-16 / 1 |

INOX STAINLESS STEEL
430

Plancha BBQ
BBQ grill



| REF. | W(mm) | L(mm) | MODELO | € | UE / MOQ |
|-------|-------|-------|--------|---|----------------|
| 11125 | 350 | 240 | NANO | | 1-0-1-4-16 / 1 |
| 11126 | 400 | 240 | SMALL | | 1-0-1-4-16 / 1 |
| 11127 | 470 | 300 | MEDIUM | | 1-0-1-4-16 / 1 |

VERMICULITE

Tapete térmico
Thermic mat

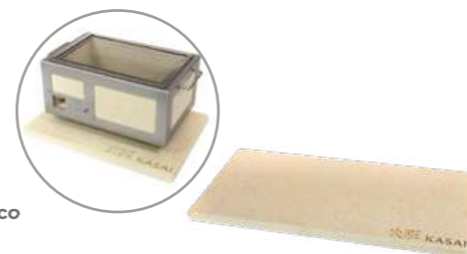

| REF. | W(mm) | L(mm) | MODELO | € | UE / MOQ |
|-------|-------|-------|--------|---|----------------|
| 11135 | 300 | 400 | NANO | | 1-0-1-4-16 / 1 |
| 11136 | 350 | 500 | SMALL | | 1-0-1-4-16 / 1 |
| 11137 | 400 | 600 | MEDIUM | | 1-0-1-4-16 / 1 |
| 11138 | 350 | 800 | LARGE | | 1-0-1-4-16 / 1 |

INOX STAINLESS STEEL
430

Malla repuesto BBQ
BBQ spare mesh



| REF. | W(mm) | L(mm) | MODELO | € | UE / MOQ |
|-------|-------|-------|--------|---|----------------|
| 11131 | 350 | 240 | NANO | | 1-0-1-4-16 / 1 |
| 11132 | 400 | 240 | SMALL | | 1-0-1-4-16 / 1 |
| 11133 | 470 | 300 | MEDIUM | | 1-0-1-4-16 / 1 |
| 11134 | 700 | 260 | LARGE | | 1-0-1-4-16 / 1 |

INOX STAINLESS STEEL
430

50:50 plancha BBQ
50:50 BBQ grill

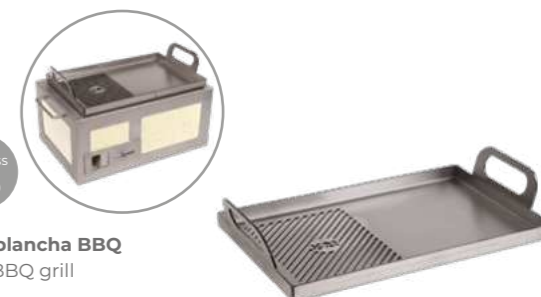

| REF. | W(mm) | L(mm) | MODELO | € | UE / MOQ |
|-------|-------|-------|--------|---|----------------|
| 11128 | 350 | 250 | NANO | | 1-0-1-4-16 / 1 |
| 11129 | 400 | 360 | SMALL | | 1-0-1-4-16 / 1 |
| 11130 | 470 | 354 | MEDIUM | | 1-0-1-4-16 / 1 |

INOX STAINLESS STEEL
430

Soporte 6 brochetas
6 skewer support

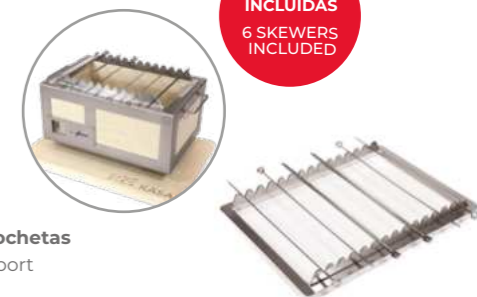

6 BROCHETAS INCLUIDAS
6 SKEWERS INCLUDED

| REF. | W(mm) | L(mm) | MODELO | € | UE / MOQ |
|-------|-------|-------|--------|---|----------------|
| 11139 | 310 | 230 | NANO | | 1-0-1-4-16 / 1 |
| 11140 | 370 | 240 | SMALL | | 1-0-1-4-16 / 1 |
| 11141 | 430 | 320 | MEDIUM | | 1-0-1-4-16 / 1 |
| 11142 | 680 | 250 | LARGE | | 1-0-1-4-16 / 1 |

NEW



* Se vende por separado
Sold separately



Llauna inox
St/st llauna
Llauna acier
Llauna acciaio
Llauna stahl



| REF. | RACIONES | W(mm) | L(mm) | H(mm) | € | UE / MOQ |
|-------|----------|-------|-------|-------|---|----------------|
| 10689 | TAPA | 115 | 226 | 20 | | 1-0-24-0-0 / 1 |
| 10690 | 1 | 115 | 331 | 20 | | 1-0-24-0-0 / 1 |
| 10691 | 2 | 230 | 331 | 20 | | 1-0-12-0-0 / 1 |

* Se vende por separado
Sold separately



Llauna CARBON STEEL
St/st llauna
Llauna acier
Llauna acciaio
Llauna stahl



| REF. | RACIONES | W(mm) | L(mm) | H(mm) | € | UE / MOQ |
|-------|----------|-------|-------|-------|---|----------------|
| 10692 | TAPA | 115 | 226 | 20 | | 1-0-24-0-0 / 1 |
| 10693 | 1 | 115 | 331 | 20 | | 1-0-24-0-0 / 1 |
| 10694 | 2 | 230 | 331 | 20 | | 1-0-12-0-0 / 1 |



Base corcho
Cork base
Support en liège
Table di sughero
Korkbasis



| REF. | W(mm) | L(mm) | H(mm) | € | UE / MOQ |
|-------|-------|-------|-------|---|----------------|
| 10698 | 129 | 238 | 20 | | 1-0-24-0-0 / 1 |
| 10699 | 129 | 343 | 20 | | 1-0-24-0-0 / 1 |
| 10700 | 244 | 343 | 20 | | 1-0-24-0-0 / 1 |

Llauna de acero inoxidable de alta calidad, apta para el uso en horno y barbacoas. Soporta temperaturas de hasta 400°C

High-quality stainless steel plate, suitable for use in ovens and barbecues. Withstands temperatures up to 400°C



Llauna fabricada en acero de carbono que le proporciona una gran dureza y resistencia. Es apto para horno, inducción y barbacoa y soporta temperaturas de hasta 220°C

The carbon steel plate is made of carbon steel, which makes it very hard and resistant. It is suitable for oven, induction and barbecue and withstands temperatures up to 220°C.



Corcho 100 % natural reciclable y reutilizable. Resistente a altas temperaturas y a la humedad. No es apto para lavavajillas.

100% natural cork, recyclable and reusable. It is resistant to high temperatures and humidity. It is not dishwasher safe.



PACKAGING
CUSTOM BOX





PLATO PIEDRA / STONE PLATE

Esta colección combina la elegancia de la cerámica con la fuerza del basalto volcánico, ofreciendo 3 formatos adaptables para presentaciones individuales o para compartir. Pensada para cocinar y mantener los alimentos calientes en mesa, es una solución práctica y visualmente atractiva.

La piedra de 10mm es perfecta para la presentación de alimentos a una temperatura óptima, mientras que la de 20mm funciona como plancha para verduras, carnes y marisco.

El diseño modular incluye una base elevada que aísla el calor y bordes inclinados para recoger grasas y líquidos con eficacia.

This collection combines the elegance of ceramic with the strength of volcanic basalt, offering three adaptable formats for individual presentations or for sharing. Designed for cooking and keeping food warm at the table, it is a practical and visually appealing solution.

The 10mm stone is perfect for presenting food at an optimal temperature, while the 20mm stone functions as a griddle for vegetables, meat or seafood.

The modular design includes a raised base to insulate heat and sloped edges to collect fats and liquids effectively. You can use one, two or no stones, as the plate alone is also ideal for presentation.

Piedra de 20mm de espesor que mantiene perfectamente el calor para presentación en mesa y acabado de punto de cocción.

20mm thickness stone maintains perfectly the heat for table presentation and finishing cooking point.



Canales para recogida de líquidos y potenciar la circulación de aire.

Liquid collecting channels enhances air circulation.

Punto de sujeción y elevación para aislamiento térmico.

Subjection point and elevation for thermal insulation.

Sus bordes inclinados facilitan la recogida de grasas y líquidos.

Sloping edges ease the fat and liquid collection.



Piedra Basalto
Basalt Stone
Pierre De Basalte
Pietra In Basalto
Basaltstein

| REF. | W(mm) | L(mm) | H(mm) | € | UE / MOQ |
|-------|-------|-------|-------|---|----------------|
| 11825 | 240 | 240 | 20 | | 1-0-39-0-0 / 1 |
| 11826 | 320 | 320 | 20 | | 1-0-25-0-0 / 1 |
| 11768 | 328 | 228 | 10 | | 1-0-50-0-0 / 1 |

PIEDRA BASALTO / BASALT STONE:

- De origen volcánico
- Ideal para acabar o presentar elaboraciones en mesa.
- Calentar en horno a un máximo de 260°C
- Volcanic origin
- Ideal for finishing or presenting dishes at the table
- Heat in the oven to a maximum of 260°C.

3 FORMATOS / 3 FORMATS:



240 x 240 mm
H: 20 mm



Ø 320 mm
H: 20 mm



328 x 228 mm
H: 10 mm

* Compatible sólo con base de corcho. REF.: 10700



PACKAGING
CUSTOM BOX



Plato Ceramica
Ceramic Dish
Assiette Porcelaine
Piatto In Porcellana
Porzellanteller

| REF. | W(mm) | L(mm) | H(mm) | € | UE / MOQ |
|-------|-------|-------|-------|---|----------------|
| 11820 | 240 | 240 | 20 | | 0-1-12-0-0 / 1 |
| 11821 | 240 | 480 | 20 | | 0-1-6-0-0 / 1 |
| 11822 | 320 | 320 | 20 | | 0-1-8-0-0 / 1 |

PLATO CERÁMICA (FALME CERAMIC):

- Cerámica muy resistente a los cambios bruscos de temperatura.
- Rápida transferencia de calor.
- Conserva el calor durante horas.
- En caso de calentar se recomienda colocar sobre una base para evitar quemaduras.
- Se recomienda lavar a mano cuando vuelva a estar a temperatura ambiente
- Ceramic highly resistant to sudden temperature changes
- Rapid heat transfer
- Retains heat for hours
- In case of heating it is recommended to place on a base to avoid burns
- It is recommended to wash by hand when it returns to room temperature.

3 FORMATOS / 3 FORMATS:



SIMPLE
240 x 240 mm
H: 20 mm



DOBLE
Ø 320 mm
H: 20 mm



REDONDO
328 x 228 mm
H: 10 mm



PACKAGING
CUSTOM BOX

Brasa / Grill



NEW



LAVAR A MANO
HAND WASH



NO APTO LAVAVAJILLAS
DISHWASHER NO SAFE

Brasa

Plato Hierro Fundido / Cast Iron Plate

Plato de hierro fundido adecuado tanto para mantener como para terminar la cocción en mesa. El plato viene acompañado de una base de madera para poder servir en mesa.

Cast iron plate suitable both for holding and for finishing cooking at the table. The plate comes with a wooden base for serving at the table.



APTO PARA BRASA
SUITABLE FOR BBQ



APTO PARA HORN
SUITABLE FOR OVEN



350°C



HIDRATAR CON ACEITE
HYDRATE WITH OIL



PLATO HIERRO FUNDIDO
CAST IRON PLATE

Aguanta hasta 350C°. Después de usar, dejar enfriar y lavar a mano con agua y jabón. Secar con un paño suave y poner una capa de aceite para mejor conservación.

It can withstand up to 350C°. After use, leave to cool and wash by hand with soap and water. Dry with a soft cloth and coat with oil for better preservation.



BASE DE ACACIA
ACACIA WOOD BASE

Base de madera acacia que sirve como soporte del plato de hierro fundido. Lavar con un paño suave.

Acacia wood base that serves as a support for the cast iron plate. Wash with a soft cloth.

INOX
STAINLESS
STEEL
304

Plato hierro fundido + Base madera acacia
Cast iron plate + Acacia wood base
Plaque en fonte + socle en bois d'acacia
Piastra in ghisa + base in legno d'acacia
Platte aus Gusseisen + Unterteller eichenholz



| REF. | Ø (mm) | € | UE / MOQ |
|-------|--------|---|---------------|
| 11973 | 320 | | 1-0-4-0-0 / 1 |
| 12007 | 350 | | 1-0-3-0-0 / 1 |



PACKAGING
CUSTOM BOX

Fabricados en cuero de alta calidad y forrados en el interior.

Manufactured in high-quality leather and lined.



Sus puños largos proporcionan una protección extra para los antebrazos.

The long cuffs provide extra protection for your forearms.

Guantes piel para horno

Leather oven gloves
Gants de four en cuir
Guanti da forno in pelle
Lederhandschuhe

* Estos guantes cumplen con la normativa Europea 2016/425 y EN 407:2004 nivel 3 relativo a los equipos de protección individual (EPI).

These gloves are compliant with EU Regulation 2016/425 concerning personal protective equipment (PPE) and meet EN 407:2004 Level 3, for work gloves.

| REF. | L(mm) | € | UE / MOQ |
|-------|-------|---|--------------------|
| 10715 | 460 | | 1-0-50-100-400 / 1 |

INOX STAINLESS STEEL 304

Escurre fritos y carnes

Fry colander
Passoire à frites
Cesta per friggere
Frittensieb



Esprai aceite

Oil spray
Pulvérisateur d'huile
Spray d'olio
Ölspray



| REF. | L(mm) | € | UE / MOQ |
|------|-------|---|---------------------|
| 9997 | 100 | | 1-0-24-288-1440 / 1 |

| REF. | W(mm) | L(mm) | € | UE / MOQ |
|------|-------|-------|---|-----------------|
| 8381 | 290 | 400 | | 1-0-6-24-24 / 1 |
| 8382 | 390 | 500 | | 1-0-4-12-24 / 1 |
| 8383 | 390 | 600 | | 1-0-3-9-27 / 1 |

Base de esparto

Placemat
Sets de table
Tovaglietta
Platzmatten



| REF. | Ø(mm) | € | UE / MOQ |
|-------|-------|---|--------------------|
| 10716 | 380 | | 1-4-48-144-576 / 1 |

NEW

Cepillo limpia barbacoa

Placemat
Sets de table
Tovaglietta
Platzmatten



| REF. | Ø(mm) | € | UE / MOQ |
|------|-------|---|----------------|
| 9995 | 380 | | 1-0-12-0-0 / 1 |

Punta plana para girar o coger alimentos con precisión.

Flat tip for precise turning or picking up food.



Pinza BBQ

BBQ tong
Pince BBQ
Pinze BBQ
BBQ zange

| REF. | L(mm) | W(mm) | H(mm) | € | UE / MOQ |
|-------|-------|-------|-------|---|----------------|
| 10682 | 405 | 100 | 27 | | 1-0-24-0-0 / 1 |

Gancho central para facilitar el manejo de las parrillas.

Central hook for easy handling of the grills.

Mango recubierto de PVC para mayor comodidad.

PVC coated handle for comfort.



Pinza BBQ plana

BBQ tong flat
Pince BBQ plain
Pinze BBQ piano
BBQ zange boden

| REF. | L(mm) | W(mm) | H(mm) | € | UE / MOQ |
|-------|-------|-------|-------|---|----------------|
| 10683 | 405 | 100 | 55 | | 1-0-24-0-0 / 1 |

INOX STAINLESS STEEL 430

Pack 6 pinchos inox

Pack 6 ss skewers inox
Pack 6 piques acier
Pack 6 spiedo acciaio
Pack 6 spießchen stahl



| REF. | L(mm) | € | UE / MOQ |
|------|-------|---|-----------------|
| 9993 | 250 | | 1-24-96-0-0 / 1 |
| 9994 | 300 | | 1-24-96-0-0 / 1 |

INOX STAINLESS STEEL 304

Pack 6 brocheta inox

Inox skewer
Inox brochette
Inox spiedo
Inox spieß



| REF. | L(mm) | € | UE / MOQ |
|-------|-------|---|---------------|
| 11493 | 35 | | 1-0-0-0-0 / 1 |
| 11494 | 20 | | 1-0-0-0-0 / 1 |

Besuguera

Fish grill
Grill à poisson
Griglie per pesce
Fischgrillkorb aus edelstahl



| REF. | SIZE | W(mm) | H(mm) | € | UE / MOQ |
|-------|------|-------|-------|---|------------------|
| 10679 | S | 165 | 80 | | 1-0-6-24-144 / 1 |
| 10680 | M | 200 | 100 | | 1-0-6-18-108 / 1 |
| 10681 | L | 290 | 120 | | 1-0-4-8-48 / 1 |



Discover
Caliu's
World

Carbón

Carbón de COCO / COCONUT Charcoal



Hecho con cáscaras de coco naturales de plantaciones certificadas y presentado en forma de briquetas cúbicas. Perfecto por su poder calorífico estable, de larga duración, sin llama, sin chispas y poco humo.

It is supplied as cubic briquettes and is created from natural coconut shells from verified plantations. Perfect for its stable, long-lasting, flame-free, non-sparking and low-smoke heating power.

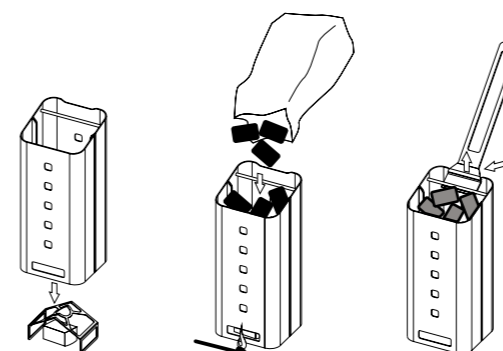

La chimenea Caliu es la mejor herramienta para encender el carbón de forma rápida, limpia y segura, en 20 minutos estará listo para empezar a cocinar.

In just 20 minutes, you'll be able to start cooking thanks to the Caliu Chimney's ability to ignite coal fast, cleanly, and safely.

INOX
STAINLESS
STEEL
430

Chimenea BBQ
Chimney BBQ
Cheminée BBQ
Grigliato camino BBQ
BBQ kamin



| REF. | W(mm) | L(mm) | H(mm) | € | UE / MOQ |
|------|-------|-------|-------|---|------------------|
| 8686 | 80 | 125 | 300 | | 1-0-4-64-128 / 1 |



Garantiza la sostenibilidad de este producto.

It guarantees the sustainability of this product.



Tiempo de combustión: 15 minutos

Burning time: 15 minutes



Pastillas naturales y ecológicas, procedentes de residuos naturales.

Natural and environmentally friendly tablets from natural waste.



No producen olores y no son tóxicas.

They are odourless and non-toxic.



Lanas de encendido

Firelighters
Laine De Bois Pour Allumage
Lana Di Legno Accendi
Bbq Anzündler



X32

| REF. | PESO | € | UE / MOQ |
|-------|-----------------|---|---------------|
| 11974 | 400gr. (aprox.) | | 1-0-0-0-0 / 1 |



Briquetas de carbón elaboradas exclusivamente a partir de cáscara de coco carbonizada y compactada.

Por su composición y su densidad, las briquetas tienen un poder calorífico muy superior a la de cualquier otra briqueta o carbón, y mantienen la combustión a plena temperatura durante casi tres horas.

No levanta polvo ni cenizas durante la combustión ni una vez finalizada, por lo que no es imprescindible la limpieza inmediata.

Charcoal briquettes are made exclusively from carbonised and compacted coconut shells.

Due to their composition and density, the briquettes have a calorific value far superior to that of any other briquette or charcoal, and maintain combustion at full temperature for almost three hours.

It does not raise dust or ashes during combustion or once it is finished, so it is not essential to clean it immediately.

CASCARA DE COCO
CARBONIZADA
Y COMPACTADA

CARBONISED AND
COMPACTED COCO-
NUT SHELLS.



Briqueta de COCO
COCONUT Briquette
Briquette de COCO
Bricchetto di COCCO
Kokosnussbrikett

| REF. | PESO(kg) | € | UE / MOQ |
|-------|----------|---|-----------------|
| 10803 | 5KG | | 1-0-0-24-72 / 1 |
| 10804 | 10KG | | 1-0-1-8-40 / 1 |



SERRÍN DE
COCO
COMPACTADO

COMPACTED CO-
CONUT SHELLS



Carbón de coco sawdust
Coconut charcoal sawdust
Charbon de coco sawdust
Carbone di cocco sawdust
Kokosnusskohle sawdust

| REF. | PESO(kg) | € | UE / MOQ |
|-------|----------|---|---------------|
| 11641 | 10 | | 1-0-1-0-0 / 1 |



+2,5 HORAS
DE COMBUSTIÓN
Y MÁXIMA EFICIENCIA
CALORÍFICA.

+2,5 HOURS
OF COMBUSTION
AND MAXIMUM
HEAT EFFICIENCY.

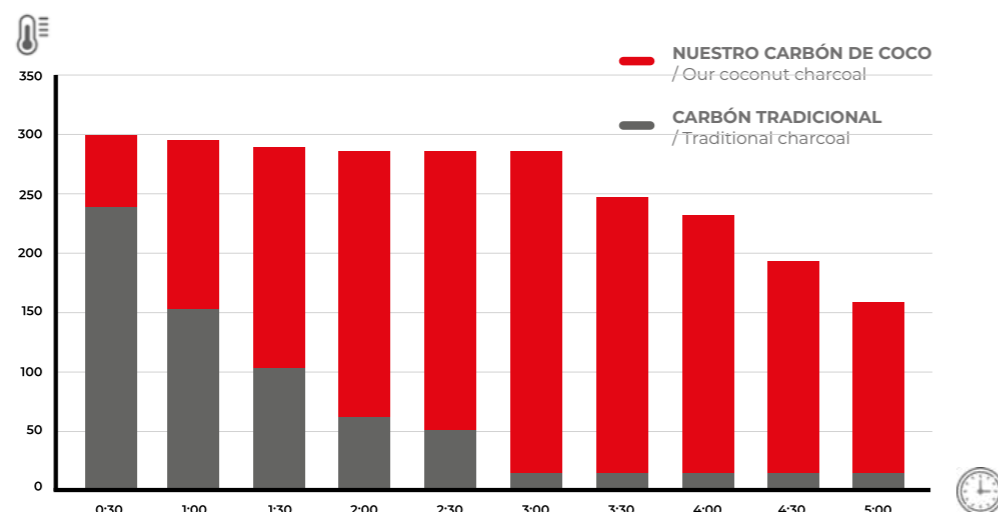

VENTAJAS CARBÓN DE COCO SAWDUST / ADVANTAGES OF SAWDUST COCONUT CHARCOAL



SIN LLAMA
Más control sobre
la cocción de
alimentos.

FLAMELESS
More control over
the cooking of
food.



SIN CHISPAS
Apto para uso
en interiores.

SPARKLESS
Suitable for
indoor use.



SIN HUMO
No altera el sabor de
los alimentos.

NO SMOKE
It does not alter the
taste of food.

- Limpio / Clean
- Eficiente / Efficient
- Económico / Economic
- Útil / Useful
- Ecológico / Ecologic
- Seguro / Safe
- Cómodo / Convenient
- Sin gases sulfúricos tóxicos / No toxic sulphuric fumes

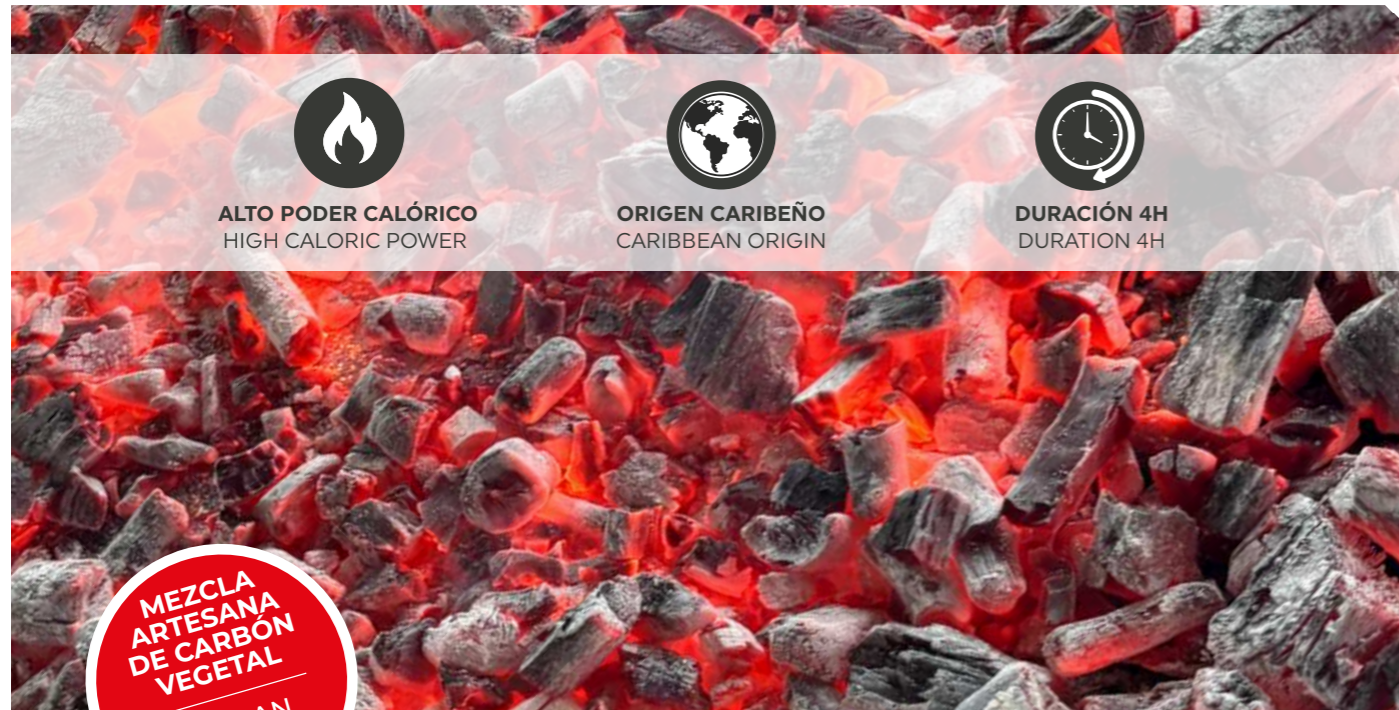

ALTO PODER CALÓRICO
HIGH CALORIC POWER



ORIGEN CARIBEÑO
CARIBBEAN ORIGIN



DURACIÓN 4H
DURATION 4H

**MEZCLA
ARTESANA
DE CARBÓN
VEGETAL**
**ARTISAN
CHARCOAL
BLEND**



MARABÚ

Alta densidad y poder calórico. Aromas nobles y baja producción de humo y ceniza.

High-density and high performance, noble aromas and low smoke and ash production.



CASUARINA

De muy alto poder calórico, proporcionando potencia y un mayor rendimiento.

Higher efficiency, providing power and increased performance.



JÚCARO

Aporta estabilidad y control a la mezcla aportando una mayor eficiencia y durabilidad.

It provides stability and control to the blend giving more efficiency and durability.



El cumplimiento de la normativa REACH garantiza el control de calidad del producto, descartando la deforestación de bosques y la mano de obra infantil.

REACH compliance guarantees product quality control, ruling out deforestation of forests and child labour.



NEW

Saco de carbón vegetal marabú, casuarina y júcaro
Vegetable charcoal marabú, casuarina and júcaro
Charbon végétal marabú, casuarina et júcaro
Carbone vegetale marabú, casuarina e júcaro
Pflanzliche Kohle marabú, casuarina und júcaro

| REF. | PESO(kg) | € | UE / MOQ |
|-------|----------|---|---------------|
| 11058 | 10 | | 1-0-1-0-0 / 1 |

Brasa

Leña y aromas

Firewood and flavour

Leña de vid procedente de viñedos de 100 años de antigüedad. Cortados en trozos pequeños y manejables que mantienen un excelente aroma.

Vine wood from 100 year old vineyards. Cut into small, manageable pieces that maintain an excellent aroma.

NEW

Madera de Vid
Vine Vid
Bois de vigne
Legno di vite
Rebenholz



| REF. | PESO(kg) | € | UE / MOQ |
|-------|----------|---|---------------|
| 12014 | 7 APROX | | 1-0-0-0-0 / 1 |

FRESCO
FRESH

Envasado según pedido para garantizar la máxima frescura y preservar todos los beneficios del producto.

We pack to order to guarantee maximum freshness and preserve all the benefits of the product.



REF: 11975

SHUNKS DE RAÍZ DE VID

- Granulometría gruesa hasta 100mm.
Coarse granulometry 100mm.

- Apto para smokers, kamados y técnicas de ahumados de larga duración.
Suitable for smokers kamados and long-lasting smoked.

- No necesita hidratación.
No hydration needed.

NEW

Bbq Aroma, Bbq Flavour, Bbq arôme, Aroma bbq, Bbq geruch.

| REF. | PESO(kg) | € | UE / MOQ |
|-------|----------|---|---------------|
| 11975 | 2 | | 1-0-0-0-0 / 1 |
| 11976 | 2 | | 1-0-0-0-0 / 1 |
| 11977 | 0,150 | | 1-0-0-0-0 / 1 |



REF: 11976

CHIPS CASCARA ALMENDRA

- Granulometría media hasta 50mm.
Coarse granulometry 50mm.

- Apto para hornos de brasa, bbq abiertas para aromatización rápida.
Suitable for ember oven, open bbq for quick aromatisation.

- No necesita hidratación.
No hydration needed.



REF: 11977

SERRÍN DE RAÍZ OLIVO / ALMENDRO

- Granulometría fina.
Fine granulometry.

- Apto para aromatizadores, para aportar aromas a las elaboraciones gastronómicas y del mundo del cocktail.
Suitable for aromatisers to provide flavoring to gastronomical elaborations and cocktail world.



**ENVASADO
SEGÚN
PEDIDO**
**PACKED
TO ORDER**



UTSET + comas

Utset y Comas se unen para poner al alcance de todos, una selección de productos minuciosamente diseñados y fabricados siguiendo los estándares de calidad de una empresa familiar con 130 de experiencia dedicados con pasión al mundo del cuchillo y su cuidado.

Este compromiso asegura la máxima calidad de nuestros productos al precio más competitivo del mercado con una orientación eficiente y personalizada.

Utset and Comas join forces to make available to everyone a selection of products meticulously designed and manufactured following the quality standards of a family company with 130 years of experience passionately dedicated to the knives world and their care.

This commitment ensures the highest quality of our products at the most competitive price in the market with efficient and personalised guidance.





CUCHILLOS DE MESA



El cuchillo de mesa UTSET, es el resultado de la demanda de restaurantes gastronómicos que deseaban poner en mesa un cuchillo de líneas muy elegantes pero a la vez discreto y sencillo, y sobre todo que cumpliera con los altos requisitos de este tipo de restaurante.

El diseño de este cuchillo en acabados de madera de olivo, de ébano y todo el surtido de colores en madera de haya estabilizada, cumple con nuestras exigencias en cuanto a ergonomía para sus medidas y unas líneas fluidas para obtener un resultado final muy elegante.

La dureza del acero dota de resistencia al filo en contacto con el plato además de permitir una fácil recuperación al afilarlo con piedra o diamante.

Gracias a la colaboración UTSET + COMAS, hemos conseguido reproducir estos cuchillos con los mismos estándares de calidad y diseño con un menor coste, logrando que sean asequibles para un mayor número de profesionales y particulares que desean calidad y exclusividad en su mesa.

Hoy en día este cuchillo ya está presente en grandes restaurantes de todo el mundo.

The UTSET table knife is the result of the demand of gastronomic restaurants that wanted to put on the table a knife with very elegant lines, but at the same time discreet and simple and above all that meets the high requirements of this type of restaurant.

The design of this knife in ebony olive wood finish and the whole range of stabilised beech wood colours meets our requirements in terms of ergonomics for its dimensions and fluid lines to obtain a very elegant result.

The hardness of the steel makes the cutting edge resistant when in contact with the plate and allows for easy recovery when sharpened with a stone or diamond.

Thanks to the UTSET+ COMAS collaboration we have managed to reproduce these knives with the same quality and design standards at a lower cost, making them affordable for a greater number of professionals and individuals who want quality and exclusivity at their table.

Nowadays this knife is already present in great restaurants all over the world.





**MESTRE MAURICI
COLLECTION**

CARBON STEEL:
JAPANESE STEEL 52100
HARDNESS 62 ± 2 HRC
BLACKEN BLADE



Cobranding



De la colaboración entre Utset y Comas surge una nueva línea de cuchillos de inspiración japonesa que combina tradición y tecnología de vanguardia. Un cuchillo de alta gama que cumple todas las exigencias de expertos cocineros.

La colección Mestre Maurici, denominada así en memoria del fundador de Utset, combina el profundo conocimiento acumulado a lo largo de los 130 años de experiencia con las técnicas artesanales niponas, famosas por su precisión y excelencia.

Su forma ergonómica, pensada para ofrecer una sensación de ligereza y equilibrio en el peso, busca reducir la fatiga y mejorar la precisión en el corte.

The collaboration between Utset and Comas has given rise to a new line of Japanese-inspired knives that combines tradition and cutting-edge technology.

The Mestre Maurici collection, named in memory of Utset's founder, combines the profound knowledge accumulated over 130 years of experience with Japanese craftsmanship techniques, renowned for their precision and excellence.

Its ergonomic shape, designed to offer a sensation of lightness and balance in weight, aims to reduce fatigue and improve cutting precision.





500

Desde que se empezó a forjar la unión entre UTSET y Comas, nuestro reto ha sido siempre poder ofrecer lo que para nosotros son algunos de los mejores cuchillos del mercado mundial.

Después de casi dos años buscando la excelencia, y ayudados por algunos de los más experimentados chefs del país, tenemos el placer de presentaros nuestra colección 130.

Su diseño ha sido modificado varias veces, para que un mismo cuchillo se comporte a la perfección en distintas técnicas de corte.

El anillo del mango simboliza el compromiso entre UTSET y COMAS y al mismo tiempo, nuestro compromiso con cada uno de nuestros clientes.

Since the union between UTSET and Comas began to be forged, our challenge has always been to offer what we consider to be some of the best knives on the world market.

After almost two years of searching for excellence, and with the help of some of the most experienced chefs in the country, we are pleased to present our 130 collection.

Its design has been modified several times, so that the same knife performs perfectly in different cutting techniques.

The ring on the handle symbolises the commitment between UTSET and COMAS and, at the same time, our commitment to each of our customers.



501

El cuchillo es un instrumento personal e intransferible. Por eso, **afilarlo y guardarlo en un lugar correcto es una parte importantísima del proceso de mantenimiento y uso**, al igual que saber elegir el cuchillo adecuado para cada tipo de corte. Porque un alimento bien cortado libera mejor su sabor y eso se transmite en el plato.

The knife is a personal and non-transferable instrument. Sharpening it and keep it therefore a very important maintenance and usage process, as it knowing how to choose the right knife for each type of cut. Because a well-cut food releases its flavour and this is transmitted to the plate.

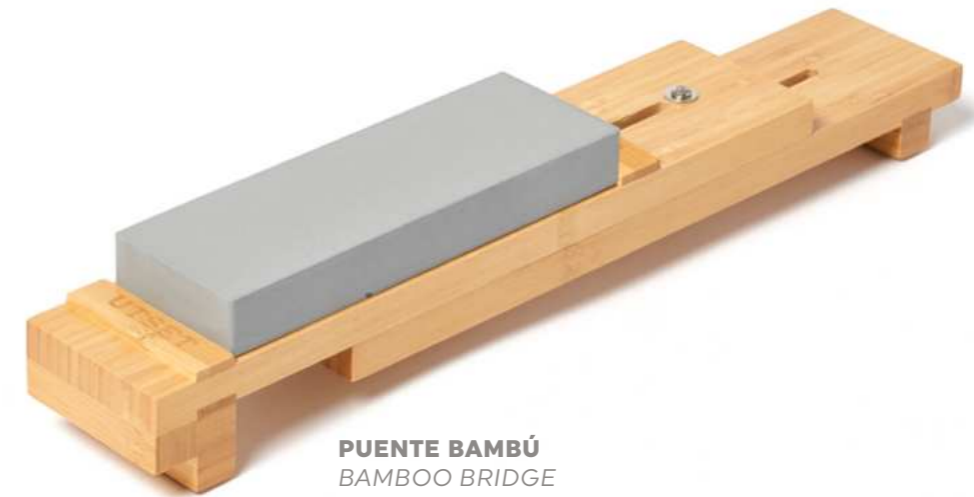

PUENTE BAMBÚ
BAMBOO BRIDGE



#400 #1000 #3000 #5000

PIEDRAS DE AFILADO NANIWA



PLACA DIAMANTADA D8X - DMT
DIAMOND PLATE

PIEL DE NOBUCK VIRGEN:
para el pulido y acabado final del afilado.

VIRGIN NOBUCK LEADER:
For polishing and final finishing of sharpening.



ASENTADOR DOBLE CARA
DOUBLE-FACED SETTLER

ÓXIDO DE CROMO:
para el asentado del cuchillo.

CHROME OXIDE:
For knife seating.



MALETÍN PORTACUCHILLOS
KNIFE-HOLDER CASE

L U E S M A  V E G A +  comas



Luesma & Vega es un estudio dedicado al diseño y producción de objetos artísticos en vidrio con técnicas contemporáneas que ha colaborado con diseñadores, decoradores y empresas, resolviendo sus necesidades.

En todos nuestros proyectos desde el inicio hay la voluntad de producir objetos bellos y duraderos, que nos acompañen y aumenten de valor con el tiempo, por eso son reparables, transformables y al final de su vida totalmente reciclables.

No queremos llenar el mundo de objetos inútiles e indiferentes, nuestras producciones son muy cuidadosas y respetuosas con el medio ambiente. Producimos a mano, una a una y en series muy limitadas con procesos no industriales

Este compromiso garantiza la máxima calidad de nuestros productos al precio más competitivo del mercado, con un asesoramiento eficaz y personalizado.

LUESMA & VEGA is a studio dedicated to the design and production of artistic glass objects using contemporary techniques that has collaborated with designers, decorators and companies to meet their needs.

In all our projects from the beginning there is the desire to produce beautiful and durable objects that accompany and increase their value over time, that is why they are repairable, transformable, and at the end of their life totally recyclable.

We do not want to fill the world with useless and indifferent objects. Our productions are truly environmentally friendly. We produce by hand one by one and in very limited series with non-industrial processes.

This commitment ensures the highest quality of our products at the most competitive price in the market with efficient and personalised guidance.





En colaboración con Luesma y Vega, Comas amplía su catálogo ofreciendo una familia compuesta de platos y soportes para snacks .

In collaboration with Luesma and Vega, Comas expands its catalogue by offering a family of plates and snack stands.

Una línea de elementos que puede cubrir fácilmente una presentación en mesa, un catering o buffet gracias a la diversidad de sus formas y tamaños que facilitará cualquier emplatado.

A line of elements that can easily cover a table presentation, a catering or buffet thanks to the diversity of its shapes and sizes that will facilitate any plating.

Con estética vintage, su color ambar que da nombre a la colección y un grabado moresco muy elegante, estas piezas son el aliado perfecto para cualquier servicio.

With vintage aesthetics, the amber colour that gives the collection its name and a very elegant moresque engraving, these pieces are the perfect ally for any service.



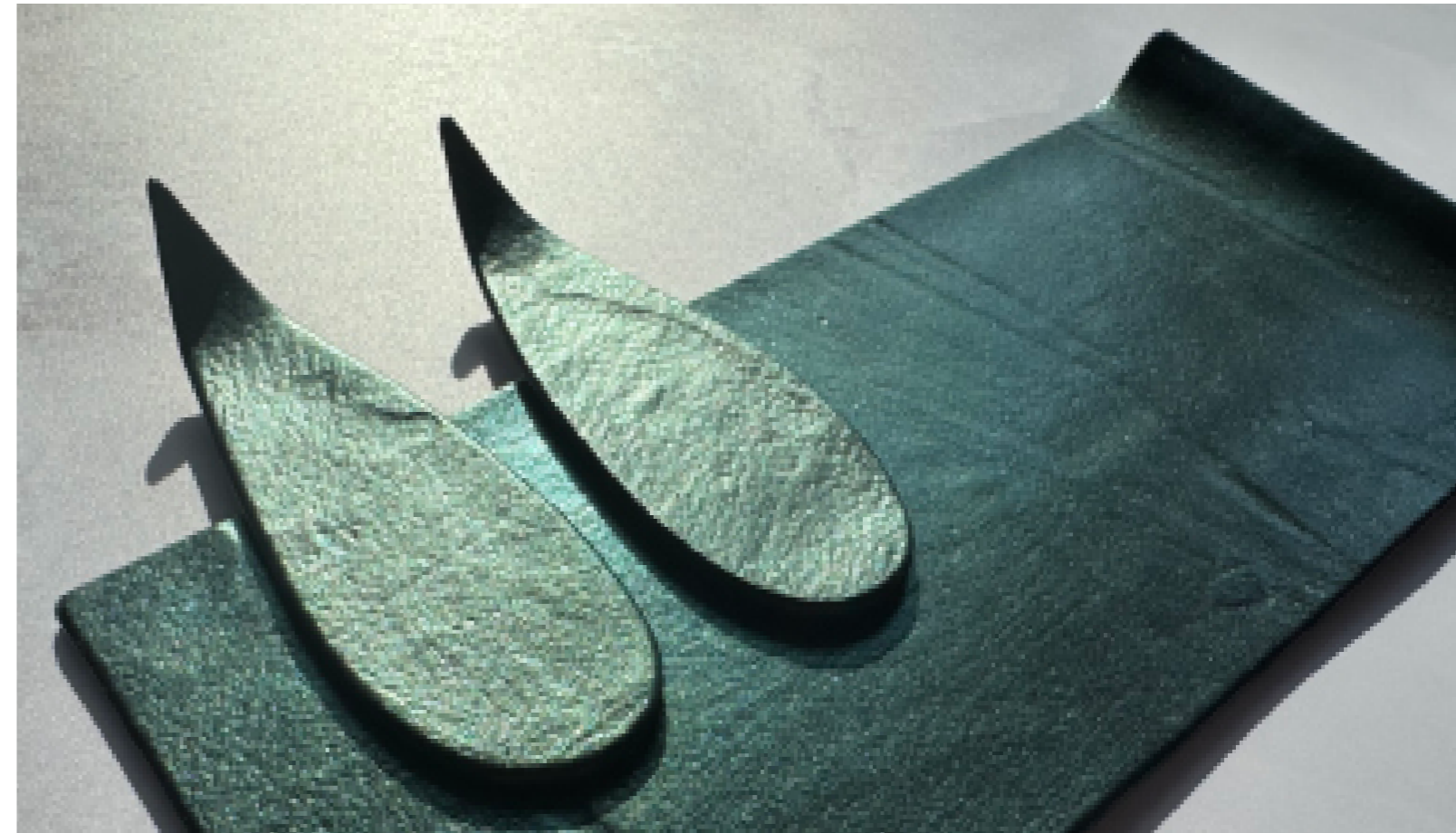

Muna Velvet es una exquisita colección de reposacubiertos, reposacucharillas y cucharillas de degustación elaborados en vidrio texturizado con un elegante acabado irisado.

Cada pieza refleja un brillo único que evoca sofisticación y delicadeza, convirtiéndola en el complemento perfecto para embellecer cualquier mesa o experiencia gastronómica.

La combinación de diseño funcional y estética deslumbrante hacen de Muna Velvet una elección ideal para quienes buscan estilo y distinción en cada detalle.

Muna Velvet is an exquisite collection of cutlery holders, spoon rests and tasting spoons crafted from textured glass with an elegant iridescent finish.

Each piece reflects a unique sheen that evokes sophistication and delicacy, making it the perfect complement to embellish any table or dining experience.

The combination of functional design and dazzling aesthetics make Muna Velvet an ideal choice for those seeking style and distinction in every detail.

bahigüell + comas

Hemos unido fuerzas con bahigüell, agencia de diseño de producto, que cuenta con una amplia experiencia en el sector gastronómico.

Aportando nuestra experiencia como fabricantes para trabajar juntos en la creación de nuevos productos gastronómicos modernos, atemporales y funcionales.

Creemos firmemente que una colaboración como esta crea una sinergia entre ambas compañías, brindando a los clientes productos innovadores que harán que su uso sea más fácil y placentero.

We have joined forces with a product design agency that has extensive experience in the gastronomic sector.

Bringing our experience as manufacturers to work together in the creation of new modern timeless and functional gastronomic products.

We strongly believe that a collaboration like this creates a synergy between the two companies providing customers with innovative products that make their daily use easier and more enjoyable.





Comas presenta LES ESSENCES, una colección pensada para vivir la experiencia de un catering exclusivo, con piezas de diseño, de líneas actuales, que se complementan entre ellas para crear una colección única.

Cada pieza es una y múltiple de la siguiente con lo que se consigue una perfecta disposición en sala, donde el equilibrio y la elegancia llenan el espacio, así como un fácil almacenaje tras cada pase.

Piezas fabricadas en materiales ligeros con formas polivalentes que optimizan las posibilidades de uso de cada una de ellas. El estudio previo de las necesidades en el servicio de catering, han dado como resultado esta gama de productos versátil capaz de satisfacer tanto a los más tradicionales como a los más transgresores.

Comas presents LES ESSENCES, a collection designed to live the experience of an exclusive catering, with designer pieces, with modern lines, which complement each other to create a unique collection.

Each piece is one and a multiple of the next, thus achieving a perfect arrangement in the room, where balance and elegance fill the space, as well as easy storage after each pass.

Pieces made of light materials with multi-purpose shapes that optimise the possibilities of use of each one of them. The previous study of the needs of the catering service has resulted in this versatile range of products capable of satisfying both the most traditional and the most transgressive.

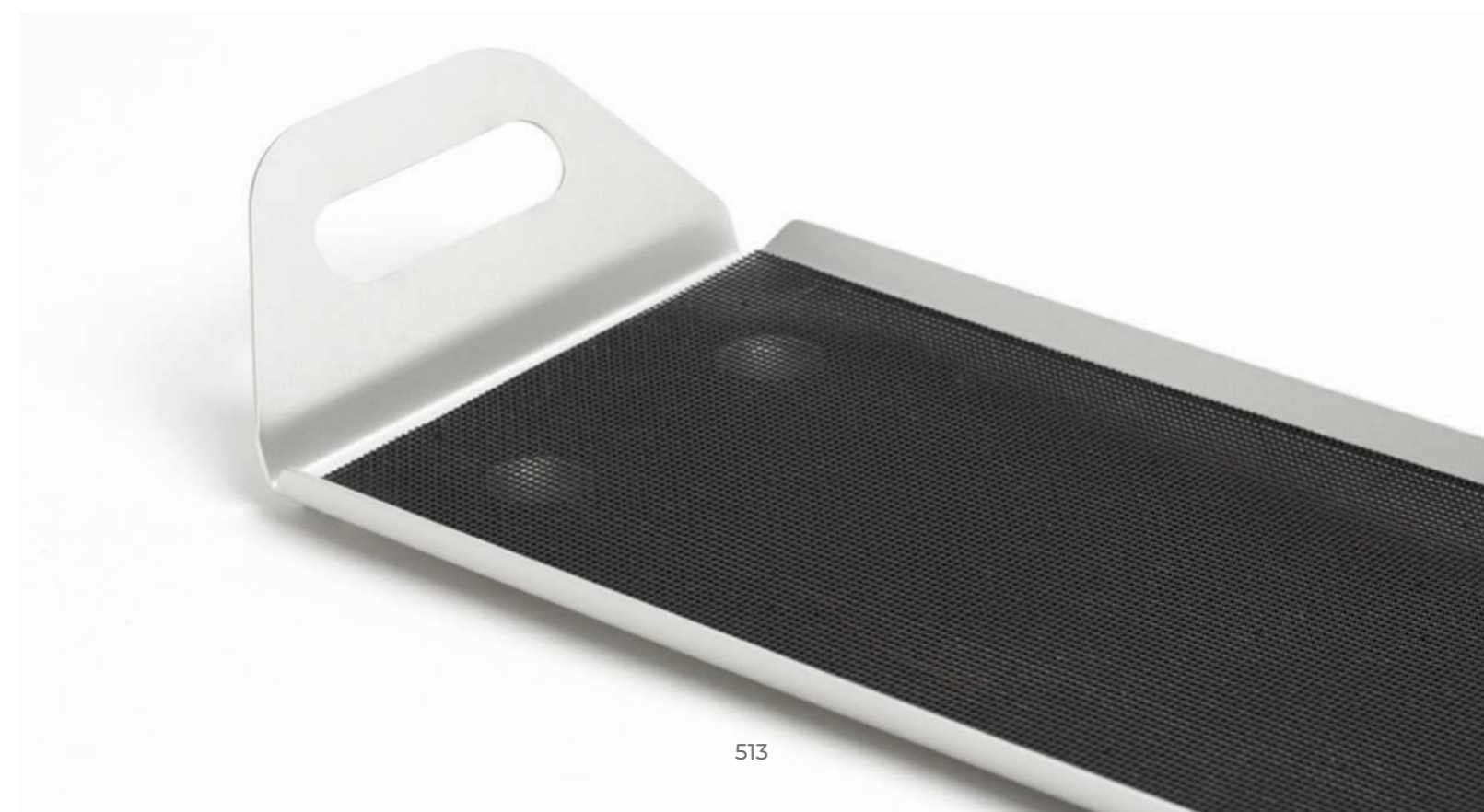



PREMIOS DELTA



PREMIOS CACTUS



PREMIOS INNOFÖRUM

CALIU & comas

Hemos unido fuerzas con bahigüell, agencia de diseño de producto, que cuenta con una amplia experiencia en el sector gastronómico. Aportando nuestra experiencia como fabricantes para trabajar juntos en la creación de nuevos productos gastronómicos modernos, atemporales y funcionales.

Creemos firmemente que una colaboración como esta crea una sinergia entre ambas compañías, brindando a los clientes productos innovadores que harán que su uso regular sea más fácil y placentero.

We have joined forces with bahigüell, a product design agency with extensive experience in the gastronomic sector. We bring our experience as manufacturers to work together in the creation of new modern, timeless and functional gastronomic products.

We firmly believe that a collaboration like this creates a synergy between both companies, providing customers with innovative products that will make their regular use easier and more enjoyable.

CALIU COLLECTION

Cobranding

Caliu es una marca de conceptos gastronómicos diseñados para crear experiencias únicas.

Caliu es un conjunto de artículos pensado para el entorno profesional actual. Fácil de usar, versátil y robusta, con un equilibrio perfecto entre estética, funcionalidad y practicidad.

Caliu is a fine dining brand designed to create unique experiences.

Caliu is a set of devices designed for today's professional environment. Easy to use, versatile and robust, with a perfect balance between aesthetics, functionality and practicality.



Discover
Caliu's
World

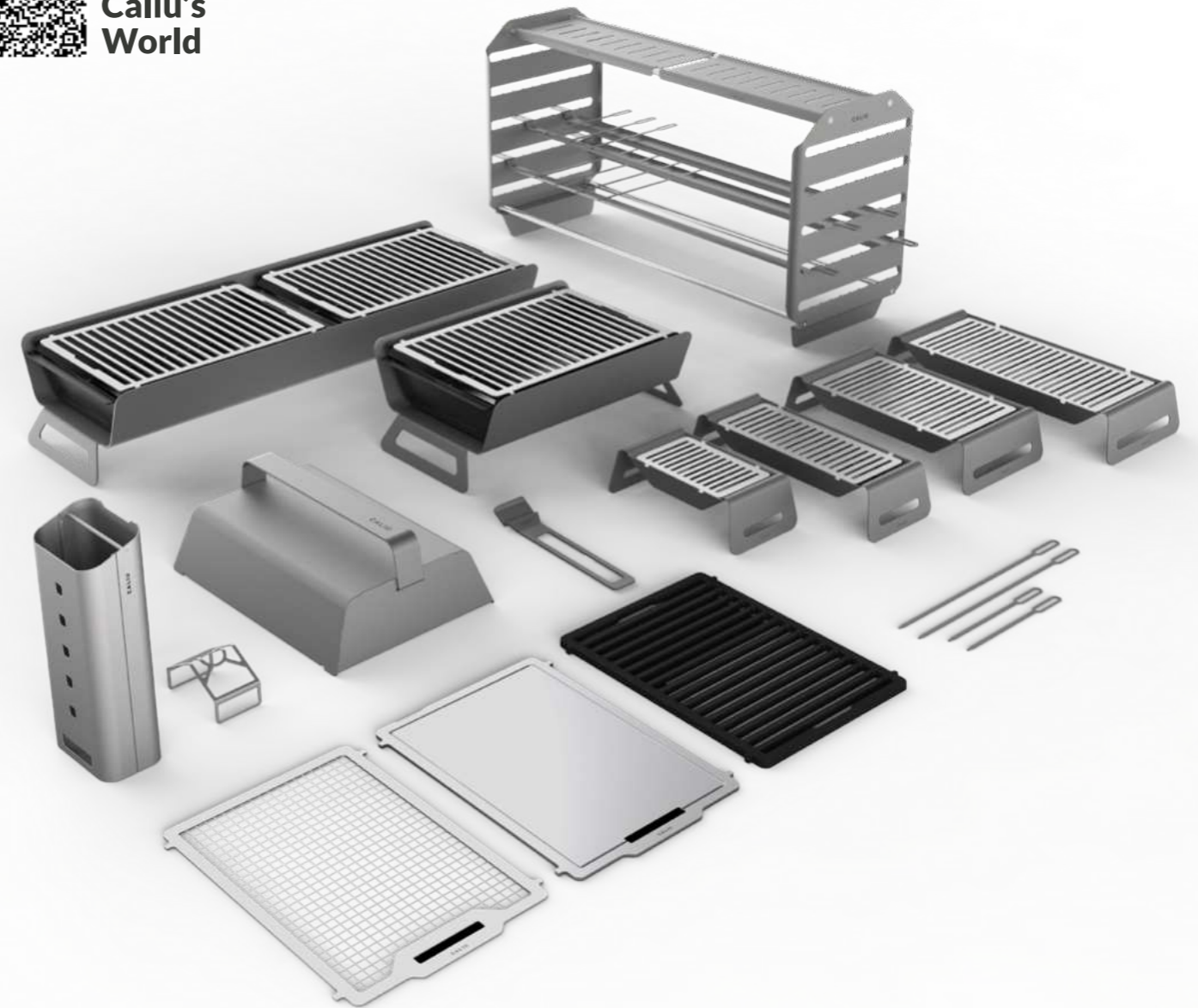

Los mejores restaurantes y Chefs han confiado en CALIU / The best restaurants and Chefs have trusted in CALIU

EL CELLER DE CAN ROCA

Manten Perastogini

Disfrutar
RESTAURANT - BARCELONA

saó
RESTAURANT

calenric

RACO PÉREZ
MIRAMAR
L'AMBA

tinas

SEMPRONIANA

dos pebrots

Carles Abellan

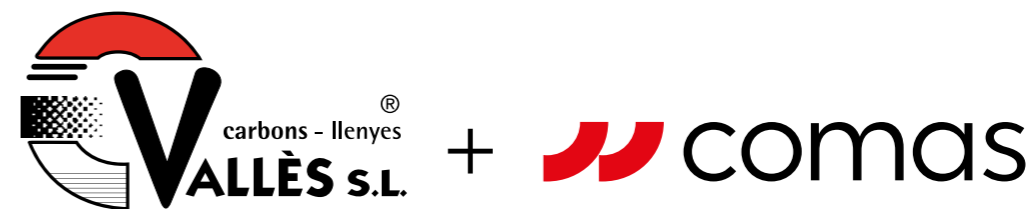

Isidre Buxó Caelles con 35 años de experiencia en el sector de las brasas de leña, carbón y ahumados, ha consolidado su posición en el mercado gracias a su experiencia y dedicación, convirtiéndose en un referente en el sector.

Cocinero autodidacta y especializado en los orígenes de la cocina a la brasa, es profesor del CIB (Culinary Institute of Barcelona).

Gerente y fundador desde sus inicios en el 1994, su empresa, Llenyes i Carbons del Vallès, se dedica a la selección y manipulación de carbones artesanales y leñas selectas para profesionales de la restauración. Su propósito es ayudar a los profesionales del sector a valorar el oficio del arte ancestral de la cocina a la brasa.

Su Know How y bagaje en el mundo de los carbones, son el motivo por el que Comas se une a Isidre, con el objetivo de ofrecer el combustible de mayor calidad a nuestros clientes.

"Isidre Buxó Caelles, with 35 years of experience in the wood, charcoal and smoked meats sector, has consolidated his position in the market thanks to his experience and dedication, becoming a benchmark in the sector."

A self-taught chef specialising in the origins of charcoal-grilled cuisine, he is a professor at the CIB (Culinary Institute of Barcelona).

Manager and founder since its beginnings in 1994, his company, Llenyes i Carbons del Vallès, is dedicated to the selection and manipulation of artisan coals and selected firewood for professionals in the restaurant industry. Its aim is to help professionals in the sector to value the craft of the ancestral art of charcoal-grilled cooking.

His know-how and experience in the world of coals are the reason why Comas joins Isidre, with the aim of offering the highest quality fossil fuel to our customers.





Con el objetivo de ofrecer productos de máxima calidad, Comas confía en Carbons Vallès quien garantiza que su carbón cumple la normativa de control de calidad REACH.

Nuestro carbón proviene de talas controladas de Cuba evitando así la deforestación y la mano de obra infantil.

With the aim of offering products of the highest quality, Comas trusts Carbons Vallès, which guarantees that its charcoal complies with regulations quality control-REACH.

Our charcoal comes from controlled logging in Cuba, thus avoiding deforestation and child labour.

Carbón estrella en cuanto a calibrado, aroma y rendimiento. Se caracteriza por su larga duración, alta temperatura y ausencia de chispas.

Star charcoal in terms of calibration, aroma and performance, characterised by its long life, high temperature and absence of sparks.



La experiencia de Isidre nos ayuda a ofrecer los mejores productos para que nuestros chefs puedan trabajar al detalle sus elaboraciones.

Añadimos una selección exclusiva de aromatizadores para brasa, de diferentes materias primas y en diferentes texturas. Todos ellos seleccionados meticulosamente para potenciar los ahumados.

Isidre's experience helps us to offer the best products so that our chefs can work in detail on their preparations.

Adding an exclusive selection of flavourings for embers, from different raw materials and in different textures. All of them meticulously selected to enhance the smoked products.



AMT proporciona productos que destacan en el mercado, satisfaciendo las demandas más exigentes de los chefs en su trabajo diario. Cada producto AMT está pensado y diseñado con la innovación en mente, de lo que surgen productos de cocina más duraderos y eficientes

Por eso en COMAS confiamos en la calidad de los productos AMT para completar nuestro catálogo y ofrecer a nuestro cliente una gama de productos de cocina de la más alta calidad.

* Plazo de entrega 1 mes / Delivery time 1 month.

AMT provides products that stand out in the market, meeting the highest demands of chefs in their daily work. Every AMT product is conceived and designed with innovation in mind, resulting in more durable and efficient kitchen products.

That is why at COMAS we rely on the quality of AMT products to complete our catalogue and offer our customer a range of kitchen products of the highest quality.

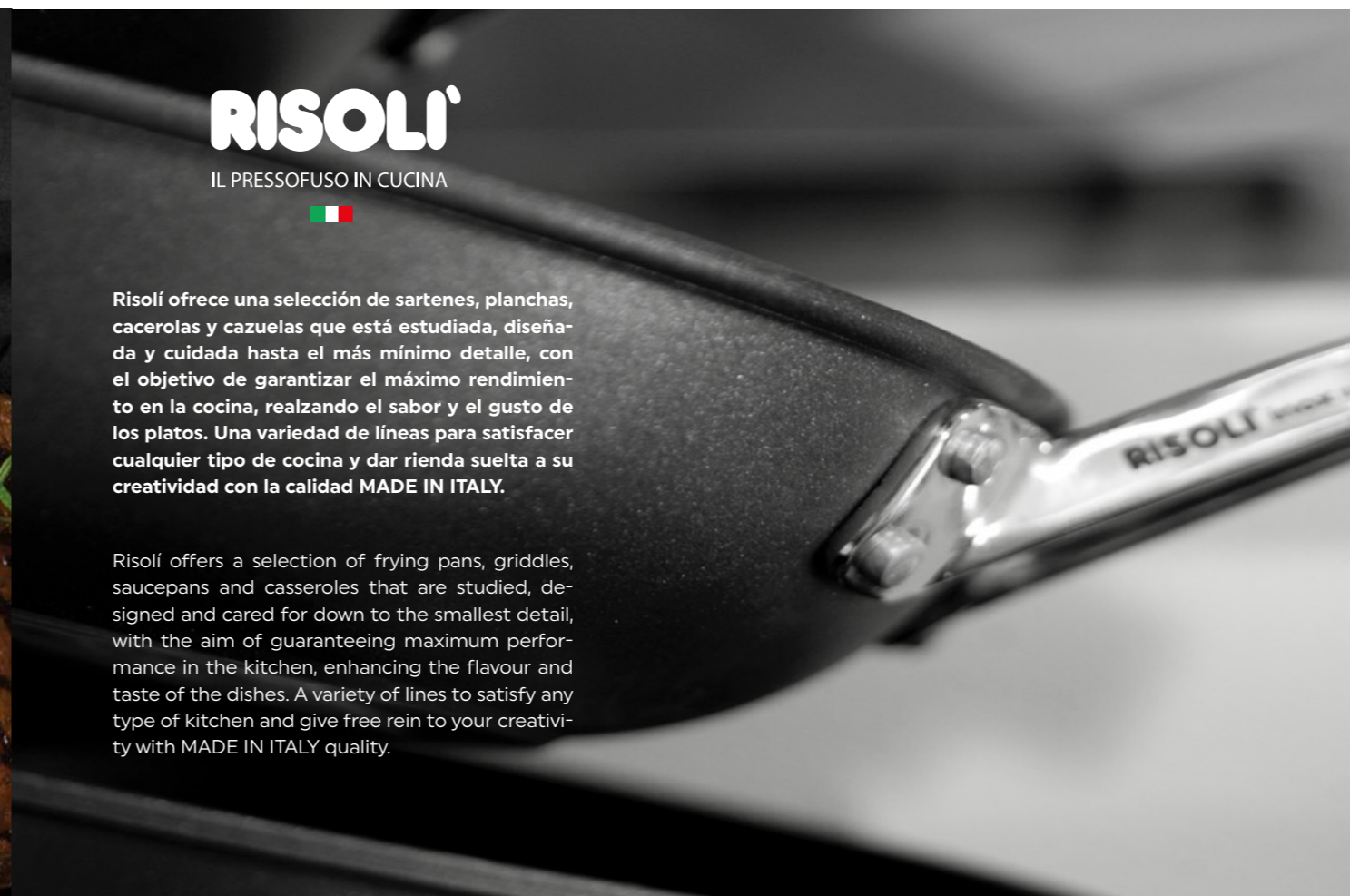

RISOLÍ

IL PRESSOFUSO IN CUCINA



Risolì ofrece una selección de sartenes, planchas, cacerolas y cazuelas que está estudiada, diseñada y cuidada hasta el más mínimo detalle, con el objetivo de garantizar el máximo rendimiento en la cocina, realzando el sabor y el gusto de los platos. Una variedad de líneas para satisfacer cualquier tipo de cocina y dar rienda suelta a su creatividad con la calidad MADE IN ITALY.

Risolì offers a selection of frying pans, griddles, saucepans and casseroles that are studied, designed and cared for down to the smallest detail, with the aim of guaranteeing maximum performance in the kitchen, enhancing the flavour and taste of the dishes. A variety of lines to satisfy any type of kitchen and give free rein to your creativity with MADE IN ITALY quality.



**THERMO
FUTURE
BOX**

Empresa alemana fundada en 2001. Líder del mercado europeo con más de 100 cajas de EPP diferentes para el transporte de productos frescos, calientes o fríos. La marca THERMO FUTURE BOX trabaja constantemente en nuevos conceptos para productos optimizados que se caracterizan por su funcionalidad, diseño, manejo, versatilidad y seguridad.

German company founded in 2001. European market leader with more than 100 different EPP boxes for the transport of fresh, hot or cold products. The THERMO FUTURE BOX brand is constantly working on new concepts for optimised products that are characterised by functionality, design, handling, versatility and safety.

Nuestro Know How en la fabricación de cubiertos se refleja en cada detalle, desde el proceso de diseño hasta el producto final, Comas despliega su experiencia para transformar la materia prima en piezas de la más alta calidad.

Our know-how in the manufacture of cutlery is reflected in every detail, from the design process to the final product, Comas deploys its experience to transform raw materials into pieces of the highest quality.

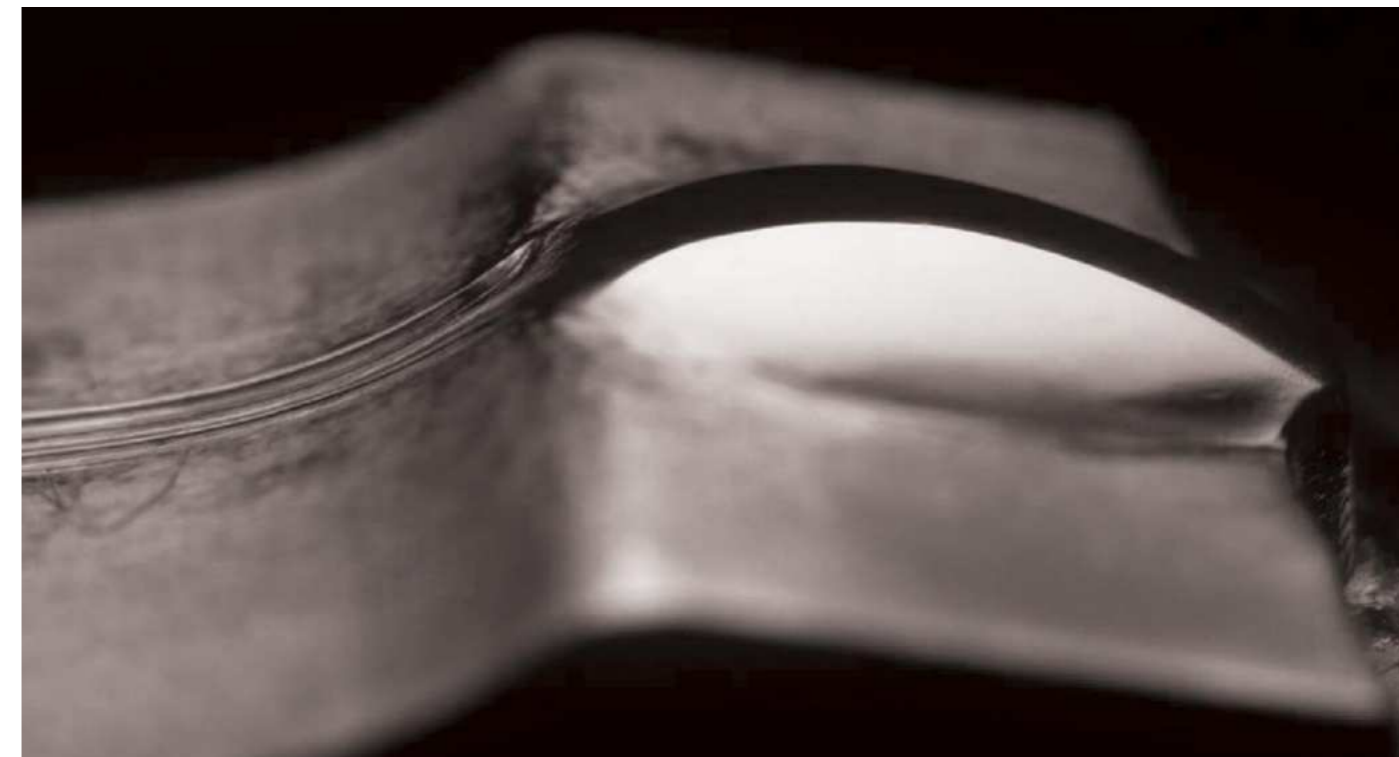

Bobina
ACERO INOXIDABLE
Stainless steel coil

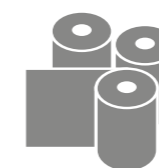

1

Material con el que se inicia la fabricación de los cubiertos.
Material with which the manufacture of cutlery begins.

Corte
Blanking



2

Se crea una forma geométrica plana (o "pieza en blanco") al introducir la bobina en una prensa y un troquel.
A geometric shape (or "blank") is created by feeding a coil of sheet metal into a press and die.

Laminación
Rolling



3

Proceso de rebaje hasta conseguir el grosor y forma correcta al pasar entre rodillos que giran en dirección opuesta.
The process of trimming to the correct thickness and shape by passing between rollers rotating in the opposite direction.

Recorte
Cutting



4

Proceso de corte donde se separa la pieza de chapa aplicando una fuerza grande para provocar la rotura del material.
Cutting process where the piece of sheet metal is separated by applying a large force to cause the material to break.

Embutición
Embossing



5

Proceso de estampado para producir diseños en relieve o hundidos o relieves en chapa.
Stamping process to produce embossed or sunken designs or reliefs on sheet metal.

Pulido
Polished



6

Proceso de afinado de forma para alisar superficies, eliminar rayones y muescas y escalar la superficie.
Shape refining process to smooth surfaces, remove scratches and indentations, and scale the surface.

Mantenimiento de cubiertos Cutlery care



Prelavado Prewash

Después de su uso, eliminar los restos de comida que podamos con la ayuda de una esponja suave.
After use, remove any food residue with a soft sponge.

Sumergirlos en agua.
Submerge them in water.



Lavado en lavavajillas Dishwasher wash

Al introducir los cubiertos en el cesto del lavavajillas, recomendamos ponerlos verticalmente con las hojas hacia arriba.
When placing cutlery in the dishwasher basket, we recommend placing them vertically with the blades facing upwards.

No utilizar detergentes excesivamente abrasivos.
Don't use excessively abrasive detergents.

Utilizar un detergente de calidad.
Use a quality detergent.

Usar un programa de lavado a temperatura inferior a 80°C y detergente con fosfatos en cantidad inferior al 10%.
Use a wash programme below 80°C and detergent with phosphate content below 10%.



Secado Drying

Nada más terminado el lavado, secar los cubiertos para evitar manchas de gotas de agua y conseguir un brillo duradero.
As soon as you have finished washing, dry the cutlery to avoid water spots and to achieve a long-lasting shine.

Secar con un paño suave.
Dry with a soft cloth.



PVD

Las piezas PVD pueden lavarse a máquina.
PVD pieces could be washed in the dishwasher.

Usar un programa de lavavajillas inferior a 80°C
Use a wash programme below 80°C

La limpieza en lavavajillas se debe realizar en posición vertical.
Stand the cutlery upright in the dishwasher

El recubrimiento PVD garantiza una resistencia de hasta 500 ciclos de lavado.
The PVD coating guarantees a resistance of up to 500 washing cycles.

Mantenimiento de cuchillos Knives care



Prelavado Prewash

Después de su uso, eliminar los restos de comida que podamos con la ayuda de una esponja suave.
After use, remove any food residue with a soft sponge.



Lavado a mano Hand wash

No utilizar estropajos metálicos o sintéticos para evitar el rayado.
Don't use metallic or synthetic scouring pads to avoid scratching.

Evita los productos de limpieza abrasivos ni agua con exceso de cloro.
Avoid abrasive cleaning products or excessively chlorinated water.



Secado Drying

Secar con paño suave desde el lomo de la hoja hacia el filo y desde el mango hasta la punta.
Dry with a soft cloth from the back of the blade to the cutting edge and from the handle to the tip.



Almacenamiento y transporte Storage and transport

Una vez seco, guardar en un estuche, funda o imán para cuchillos. De esta manera preservaremos el filo en buen estado por más tiempo.
Once dry, store in a case or sheath or in a knife magnet. This will preserve the sharpness for a longer period of time.



Afilado Sharpening

Es conveniente repasar el afilado de los cuchillos periódicamente para mantener la calidad del filo y la seguridad y precisión del corte.
It is advisable to sharpen knives regularly to maintain the quality of the cutting edge and the safety and precision of the cut.

Custom Packs

MAZOS

- GRANADA / BAGUETTE
- CUBA / LUNA
- MADRID / BARCELONA / MUNICH
- VIENA / LONDON
- BILBAO / INGLES / MALVARROSA
- MIA / ONLINE / CHEESE
- IBIZA / OSLO / HIDRAULIC / NICE
- HOTEL / ALIDA / CANADA
- SEVILLA / CHEF / NORTH



1



8



9



10



2

????



3



4



11



12



5



6



7



13

1. MAZOS Para cuchillos, cucharas y tenedores **2. CAJA 12 UNIDADES PVC** Box 12 units PVC **3. BLISTER CHULETEROS** Blister knives **4. BLISTER 4 PIEZAS FINGER FOOD** Blister 4 units Finger Food **5. BLISTER CARTÓN COMAS** Blister Comas **6. CAJA 12 UNIDADES VENTANA** Box 12 units window **7. CAJA 12 UNIDADES VENTANA KRAFT** Box 12 units windows kraft **8. CAJA 6 CHULETEROS MADERA** Wood box 6 steak knife **9. CAJA 6 CHULETEROS KRAFT** Kraft box 6 steak knife **10. CAJA 12 UNIDADES** Box 12 units **11. CAJA 16 , 24 Y 30 UNIDADES COMAS** Comas Box 16, 24 and 30 units **12. CAJA 16 , 24 Y 30 UNIDADES COMAS AUTOR** Comas Autor Box 16, 24 and 30 units **13. ESTUCHE 24 PIEZAS MADERA** 24 pieces wooden pack.

NEW

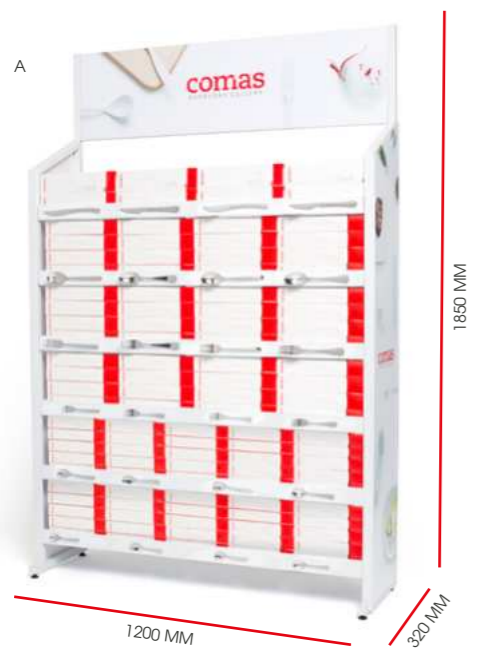

| | € | ✕ mm | ✕ mm | 🔪 | 🔪 |
|---|----------|------|------|------------------------------|-------------|
| A 7531 MUEBLE EXPOSITOR DOCENAS COMAS hospitality dozen comas display stand | 763,38 € | 1200 | 1850 | 4 COLEC. 1 MASTER POR REF | 2880 PIEZAS |
| B 5565 MUEBLE EXPOSITOR HOSTELERÍA horeca stand | 817,56 € | 1280 | 1823 | 5 COLEC. 1 MASTER POR REF | 1440 PIEZAS |
| C 5564 MUEBLE EXPOSITOR BLISTER LACASA blister Lacasa stand white | 257,67 € | 480 | 2100 | 3 COLEC. + 27 REFERENCIAS | 764 PACKS |
| D 6792 MUEBLE EXPOSITOR MENAJE kitchenware stand | 261,51 € | 675 | 2136 | 4 COLEC. 1 MASTER POR REF | 2880 PIEZAS |
| E 5650 MUEBLE EXPOSITOR MADERA wood stand | 808,82 € | 542 | 1700 | 3 COLEC. 4 INNER POR REF | 576 PIEZAS |
| F 6791 MUEBLE EXPOSITOR BLISTER / MAZO comas stand LACASA | 510,97 € | 480 | 2100 | 3 COLEC. + 27 REFERENCIAS | 764 PACKS |

| | € | ✕ mm | ✕ mm |
|---|----------|------|------|
| A 1881 MUEBLE EXPOSITOR MADERA MENAJE wooden exhibitor furniture kitchenware, exposant en bois meubles cuisine, esposito- re in legno mobile articoli da cucina, ausstellermöbel aus holz küchengeräte | 517,66 € | 801 | 2137 |
| B 1884 MUEBLE EXPOSITOR MADERA CUCHILLOS wooden knives display furniture, mobilier de présentation de couteaux en bois, mo- bile espositore coltelli in legno, holzmesser ausstellungsmöbel | 474,52 € | 477 | 1758 |



G



H



I



J



A

1600 MM

440 MM

720 MM



B



C



D



E

| | € | mm | mm | COLEC. | PIEZAS |
|---|----------|-----|------|-------------|--------------|
| G 5570 EXPOSITOR SOBREMESA COMAS counter display, présentoir 4 pièces, espositore da tavola, besteck-präsentations-ständer klein | 30,53 € | 235 | 320 | 1 COLEC. | 4 PIEZAS |
| H 5571 EXPOSITOR SOBREMESA CUCHILLOS totem display stand, présentoir totem mobile, espositore totem, besteck-präsentations-ständer groß | 53,42 € | 400 | 330 | 1 COLEC. | 7 PIEZAS |
| I 5648 EXPOSITOR BANDEROLA COMAS comas flag display stop rayon, comas espositore a bandiera, comas fahnen-besteck-display | 53,42 € | 440 | 270 | 1 COLEC. | 4 PIEZAS |
| J 5646 MUEBLE EXPOSITOR TOTEM COMAS totem display stand, présentoir totem, mobile espositore, totem besteck-präsentations-ständer groß | 325,17 € | 301 | 1869 | 8-16 COLEC. | 32-64 PIEZAS |

| | | | | | |
|---|----------|-----|------|----------|------------------|
| A 7824 BASE MUEBLE EXPOSITOR NEGRO COMAS AUTOR comas autor display stand | 693,98 € | 720 | 1600 | 1 COLEC. | 1 MASTER POR REF |
| A 7597 TABLERO EXPOSITOR MUEBLE MADERA COMAS black wooden display stand comas autor | 25,02 € | | | | |
| B 7780 AUTOR black wooden display stand lab | 25,02 € | | | | |
| C 7781 TABLERO EXPOSITOR MUEBLE MADERA LAB black wooden display stand comas kodai | 25,02 € | | | | |
| D 7782 TABLERO EXPOSITOR MUEBLE MADERA KODAI black wooden display stand sakura | 25,02 € | | | | |
| E 7888 TABLERO EXPOSITOR MUEBLE MADERA SAKURA black wooden display stand steak knives | 25,02 € | | | | |
| TABLERO EXPOSITOR MADERA CHULETERO HQ | | | | | |

Sostenibilidad Sustainability



Trabajamos para desarrollar un proceso industrial sostenible con combustibles que contribuyen a reducir las emisiones de CO2.

We are working to develop a sustainable industrial process using fuel that helps to reduce CO2 emissions.



Diseñamos embalajes con materiales reciclables para crear el menor impacto medioambiental posible.

We are designing packaging with recyclable materials to reduce the environmental impact as far as possible.



Controlamos el vertido de residuos para proteger la sostenibilidad del planeta.

We monitor our waste disposal to protect the planet's sustainability.

Renovamos el compromiso ISO We renew our ISO commitment.

Acredita que en Comas aplicamos medidas de gestión medioambiental, con el fin de reducir el impacto de nuestra empresa en el medio ambiente.

Shows that Comas implements an environmental management system in order to reduce the impact of our business on the environment.



Certifica tanto la calidad en nuestro sistema productivo como en los procesos logísticos, administrativos y de dirección de Comas.

Shows the quality of Comas' system of production and logistical, administrative and management processes.



En los últimos años Comas ha trabajado para crear una compañía sostenible, social y medioambiental.

Trabajamos la sostenibilidad desde fases iniciales de diseño, desarrollando ideas y acciones que contribuyan a reducir daños en nuestro planeta y eviten el agotamiento de recursos. Desarrollamos valores sostenibles en todos los ámbitos de la compañía para una correcta gestión ambiental.

In recent years, Comas has been working to build a business that is sustainable both socially and environment.

We work to achieve sustainability from the early phases of design, concept development and take action to reduce harm to the planet and avoid over-use of resources. We follow values of sustainability in all areas of the business to ensure rigorous environmental management.

Índice referencia / Reference index

| REF. | PAG. | REF. | PAG. | REF. | PAG. | REF. | PAG. | REF. | PAG. | REF. | PAG. | REF. | PAG. | REF. | PAG. | REF. | PAG. |
|------|------|------|------|------|------|------|------|------|------|------|------|-------------|------|------|------|------|------|
| 7069 | 51 | 7153 | 164 | 7454 | 397 | 7514 | 386 | 7582 | 449 | 7793 | 387 | 7979 | 71 | 8348 | 281 | 8434 | 413 |
| 7070 | 51 | 7154 | 164 | 7455 | 397 | 7515 | 385 | 7583 | 459 | 7794 | 387 | 7980 | 57 | 8349 | 281 | 8435 | 413 |
| 7071 | 51 | 7155 | 164 | 7456 | 397 | 7516 | 385 | 7584 | 459 | 7795 | 387 | 7981 | 57 | 8350 | 281 | 8436 | 413 |
| 7072 | 51 | 7156 | 164 | 7457 | 397 | 7517 | 385 | 7585 | 458 | 7824 | 531 | 7982 | 57 | 8351 | 282 | 8437 | 423 |
| 7073 | 51 | 7157 | 164 | 7458 | 399 | 7518 | 385 | 7586 | 458 | 7826 | 387 | 7983 | 57 | 8352 | 282 | 8438 | 423 |
| 7074 | 51 | 7158 | 164 | 7459 | 399 | 7519 | 385 | 7587 | 458 | 7827 | 387 | 7984 | 57 | 8353 | 282 | 8439 | 269 |
| 7075 | 51 | 7159 | 164 | 7461 | 262 | 7520 | 385 | 7588 | 448 | 7828 | 387 | 7985 | 57 | 8354 | 282 | 8440 | 269 |
| 7076 | 51 | 7160 | 164 | 7462 | 262 | 7521 | 386 | 7589 | 449 | 7829 | 387 | 7986 | 57 | 8355 | 282 | 8441 | 269 |
| 7077 | 51 | 7207 | 141 | 7463 | 262 | 7522 | 386 | 7590 | 448 | 7830 | 390 | 7987 | 57 | 8356 | 282 | 8442 | 269 |
| 7078 | 51 | 7208 | 141 | 7464 | 262 | 7523 | 387 | 7591 | 449 | 7831 | 390 | 7988 | 57 | 8357 | 282 | 8443 | 269 |
| 7079 | 51 | 7209 | 141 | 7465 | 262 | 7524 | 387 | 7592 | 459 | 7832 | 390 | 7989 | 57 | 8358 | 282 | 8444 | 269 |
| 7080 | 51 | 7210 | 141 | 7466 | 262 | 7525 | 386 | 7593 | 459 | 7833 | 416 | 8000 | 41 | 8359 | 282 | 8445 | 269 |
| 7081 | 49 | 7211 | 141 | 7467 | 262 | 7526 | 386 | 7594 | 458 | 7834 | 416 | 8001 | 42 | 8370 | 42 | 8446 | 269 |
| 7082 | 49 | 7271 | 66 | 7468 | 262 | 7527 | 386 | 7595 | 458 | 7835 | 416 | 8002 | 41 | 8371 | 42 | 8447 | 269 |
| 7083 | 49 | 7272 | 66 | 7469 | 262 | 7528 | 386 | 7597 | 531 | 7836 | 416 | 8003 | 41 | 8373 | 171 | 8448 | 269 |
| 7084 | 49 | 7273 | 66 | 7470 | 262 | 7529 | 386 | 7598 | 398 | 7837 | 417 | 8004 | 41 | 8378 | 115 | 8449 | 269 |
| 7085 | 49 | 7274 | 66 | 7471 | 262 | 7530 | 386 | 7599 | 398 | 7838 | 417 | 8005 | 41 | 8381 | 486 | 8450 | 269 |
| 7086 | 49 | 7275 | 66 | 7472 | 262 | 7531 | 528 | 7621 | 55 | 7839 | 417 | 8006 | 41 | 8382 | 486 | 8451 | 275 |
| 7087 | 49 | 7276 | 47 | 7473 | 263 | 7532 | 192 | 7624 | 55 | 7840 | 402 | 8007 | 57 | 8383 | 486 | 8452 | 275 |
| 7088 | 49 | 7277 | 51 | 7474 | 263 | 7533 | 392 | 7625 | 55 | 7841 | 111 | 8008 | 57 | 8384 | 270 | 8453 | 275 |
| 7089 | 49 | 7278 | 49 | 7475 | 263 | 7534 | 392 | 7626 | 55 | 7842 | 111 | 8009 | 168 | 8385 | 270 | 8470 | 248 |
| 7090 | 49 | 7279 | 47 | 7476 | 263 | 7535 | 223 | 7627 | 55 | 7843 | 111 | 8010 | 168 | 8386 | 270 | 8471 | 248 |
| 7091 | 49 | 7280 | 51 | 7477 | 263 | 7536 | 223 | 7628 | 55 | 7844 | 111 | 8083 | 156 | 8387 | 400 | 8472 | 248 |
| 7092 | 49 | 7281 | 49 | 7478 | 263 | 7537 | 223 | 7629 | 55 | 7845 | 451 | 8084 | 156 | 8388 | 400 | 8473 | 422 |
| 7093 | 402 | 7285 | 47 | 7479 | 263 | 7538 | 223 | 7630 | 55 | 7846 | 451 | 8085 | 156 | 8389 | 400 | 8474 | 259 |
| 7094 | 402 | 7286 | 51 | 7480 | 380 | 7539 | 389 | 7665 | 37 | 7847 | 451 | 8086 | 156 | 8390 | 402 | 8476 | 261 |
| 7095 | 402 | 7287 | 49 | 7481 | 380 | 7540 | 389 | 7670 | 452 | 7848 | 451 | 8087 | 156 | 8391 | 402 | 8479 | 409 |
| 7096 | 402 | 7288 | 79 | 7482 | 380 | 7541 | 416 | 7671 | 453 | 7869 | 45 | 8088 | 156 | 8392 | 400 | 8480 | 274 |
| 7097 | 402 | 7418 | 66 | 7483 | 380 | 7542 | 389 | 7672 | 453 | 7888 | 531 | 8108 | 234 | 8393 | 400 | 8481 | 274 |
| 7098 | 402 | 7419 | 66 | 7484 | 380 | 7543 | 389 | 7673 | 453 | 7889 | 428 | 8109 | 234 | 8394 | 402 | 8482 | 274 |
| 7099 | 402 | 7420 | 66 | 7485 | 380 | 7544 | 389 | 7674 | 381 | 7890 | 33 | 8110 | 234 | 8395 | 423 | 8483 | 274 |
| 7100 | 402 | 7421 | 138 | 7486 | 380 | 7545 | 389 | 7675 | 381 | 7891 | 33 | 8111 | 234 | 8396 | 423 | 8484 | 274 |
| 7101 | 402 | 7422 | 138 | 7487 | 380 | 7546 | 389 | 7676 | 381 | 7899 | 118 | 8112 | 235 | 8398 | 267 | 8485 | 274 |
| 7102 | 379 | 7423 | 138 | 7488 | 380 | 7548 | 389 | 7677 | 381 | 7900 | 118 | 8113 | 235 | 8399 | 267 | 8486 | 274 |
| 7103 | 379 | 7424 | 138 | 7489 | 380 | 7549 | 417 | 7678 | 381 | 7901 | 118 | 8114 | 235 | 8400 | 267 | 8487 | 274 |
| 7104 | 379 | 7425 | 153 | 7490 | 377 | 7550 | 417 | 7679 | 452 | 7902 | 116 | 8115 | 235 | 8401 | 267 | 8488 | 274 |
| 7105 | 379 | 7426 | 153 | 7491 | 376 | 7551 | 116 | 7680 | 453 | 7903 | 116 | 8116 | 234 | 8402 | 267 | 8489 | 274 |
| 7106 | 379 | 7427 | 153 | 7492 | 377 | 7552 | 119 | 7681 | 453 | 7917 | 153 | 8117 | 234 | 8403 | 267 | 8500 | 467 |
| 7107 | 379 | 7428 | 153 | 7493 | 376 | 7553 | 117 | 7737 | 67 | 7930 | 450 | 8118 | 235 | 8404 | 267 | 8505 | 291 |
| 7112 | 393 | 7429 | 153 | 7494 | 377 | 7554 | 138 | 7765 | 74 | 7931 | 451 | 8119 | 235 | 8405 | 267 | 8507 | 259 |
| 7113 | 409 | 7430 | 153 | 7495 | 376 | 7555 | 138 | 7766 | 74 | 7957 | 66 | 8181 | 469 | 8406 | 267 | 8508 | 192 |
| 7116 | 428 | 7431 | 196 | 7496 | 377 | 7564 | 457 | 7767 | 74 | 7958 | 429 | 8182 | 475 | 8407 | 267 | 8509 | 283 |
| 7119 | 94 | 7432 | 196 | 7497 | 376 | 7565 | 457 | 7770 | 74 | 7959 | 429 | 8183 | 475 | 8413 | 407 | 8510 | 283 |
| 7120 | 96 | 7433 | 196 | 7498 | 379 | 7566 | 457 | 7771 | 74 | 7960 | 428 | 8184 | 170 | 8414 | 407 | 8511 | 283 |
| 7121 | 100 | 7438 | 451 | 7499 | 379 | 7567 | 457 | 7772 | 74 | 7963 | 119 | 8301 | 223 | 8415 | 407 | 8512 | 283 |
| 7122 | 97 | 7439 | 451 | 7500 | 379 | 7568 | 457 | 7773 | 74 | 7964 | 119 | 8302 | 223 | 8416 | 407 | 8513 | 283 |
| 7123 | 104 | 7440 | 451 | 7501 | 382 | 7569 | 457 | 7774 | 74 | 7965 | 117 | 8303 | 223 | 8417 | 407 | 8514 | 283 |
| 7124 | 105 | 7441 | 451 | 7502 | 382 | 7570 | 457 | 7775 | 74 | 7966 | 117 | 8304 | 223 | 8418 | 407 | 8515 | 283 |
| 7142 | 164 | 7442 | 200 | 7503 | 382 | 7571 | 457 | 7776 | 74 | 7968 | 71 | 8334 | 170 | 8419 | 407 | 8516 | 283 |
| 7143 | 164 | 7443 | 200 | 7504 | 383 | 7572 | 457 | 7778 | 398 | 7969 | 71 | 8335 | 170 | 8420 | 407 | 8517 | 283 |
| 7144 | 164 | 7445 | 199 | 7505 | 383 | 7573 | 457 | 7779 | 398 | 7970 | 71 | 8336 | 170 | 8421 | 407 | 8518 | 283 |
| 7145 | 164 | 7446 | 199 | 7506 | 382 | 7574 | 457 | 7780 | 531 | 7971 | 71 | 8337 | 170 | 8426 | 410 | 8519 | 283 |
| 7146 | 164 | 7447 | 199 | 7507 | 382 | 7575 | 457 | 7781 | 531 | 7972 | 71 | 8338 | 170 | 8427 | 410 | 8520 | 283 |
| 7147 | 164 | 7448 | 258 | 7508 | 382 | 7576 | 457 | 7782 | 531 | 7973 | 71 | 8342 | 281 | 8428 | 410 | 8523 | 219 |
| 7148 | 164 | 7449 | 262 | 7509 | 382 | 7577 | 457 | 7784 | 81 | 7974 | 71 | 8343 | 281 | 8429 | 413 | 8525 | 219 |
| 7149 | 164 | 7450 | 262 | 7510 | 382 | 7578 | 457 | 7789 | 383 | 7975 | 71 | 8344 | 281 | 8430 | 422 | 8526 | 219 |
| 7150 | 164 | 7451 | 397 | 7511 | 386 | 7579 | 448 | 7790 | 383 | 7976 | 71 | 8345 | 281 | 8431 | 413 | 8527 | 219 |
| 7151 | 164 | 7452 | 397 | 7512 | 386 | 7580 | 449 | 7791 | 383 | 7977 | 71 | 8346 | 281 | 8432 | 410 | 8529 | 220 |
| 7152 | 164 | 7453 | 397 | 7513 | 386 | 7581 | 448 | 7792 | 387 | 7978 | 71 | 8347 | 281 | 8433 | 410 | 8532 | 220 |

Índice referencia / Reference index

| REF. | PAG. | REF. | PAG. | REF. | PAG. | REF. | PAG. | REF. | PAG. | REF. | PAG. | REF. | PAG. | REF. | PAG. | REF. | PAG. |
|------|------|------|------|------|------|-------|------|-------|------|-------|------|-------|------|-------|------|-------|------|
| 8640 | 37 | 8955 | 281 | 9714 | 265 | 9976 | 281 | 10049 | 317 | 10108 | 229 | 10192 | 322 | 10263 | 325 | 10596 | 329 |
| 8641 | 37 | 8956 | 281 | 9715 | 265 | 9984 | 42 | 10050 | 317 | 10109 | 228 | 10194 | 322 | 10264 | 307 | 10612 | 330 |
| 8642 | 37 | 8957 | 281 | 9716 | 265 | 9985 | 371 | 10051 | 317 | 10110 | 228 | 10195 | 322 | 10265 | 325 | 10614 | 330 |
| 8643 | 37 | 8958 | 282 | 9717 | 265 | 9986 | 371 | 10052 | 317 | 10111 | 228 | 10196 | 322 | 10266 | 325 | 10615 | 330 |
| 8644 | 37 | 8959 | 282 | 9718 | 265 | 9987 | 371 | 10053 | 317 | 10112 | 228 | 10197 | 323 | 10267 | 325 | 10617 | 329 |
| 8645 | 37 | 8960 | 282 | 9719 | 265 | 9988 | 371 | 10054 | 318 | 10113 | 228 | 10199 | 323 | 10268 | 325 | 10618 | 329 |
| 8646 | 37 | 8961 | 282 | 9720 | 265 | 9989 | 371 | 10055 | 318 | 10114 | 227 | 10200 | 323 | 10269 | 325 | 10619 | 329 |
| 8647 | 37 | 8962 | 413 | 9721 | 265 | 9990 | 371 | 10056 | 318 | 10115 | 227 | 10201 | 323 | 10270 | 325 | 10620 | 329 |
| 8648 | 37 | 8963 | 413 | 9722 | 265 | 9993 | 487 | 10057 | 307 | 10116 | 227 | 10203 | 323 | 10271 | 325 | 10621 | 329 |
| 8649 | 37 | 8964 | 290 | 9723 | 265 | 9994 | 487 | 10058 | 318 | 10117 | 227 | 10205 | 323 | 10272 | 325 | 10622 | 329 |
| 8650 | 37 | 8965 | 290 | 9724 | 265 | 9995 | 486 | 10059 | 318 | 10118 | 229 | 10206 | 323 | 10273 | 325 | 10630 | 330 |
| 8651 | 37 | 8966 | 290 | 9725 | 265 | 9997 | 486 | 10060 | 315 | 10119 | 228 | 10207 | 323 | 10409 | 347 | 10632 | 330 |
| 8652 | 37 | 8967 | 290 | 9726 | 265 | 10000 | 304 | 10061 | 315 | 10120 | 228 | 10209 | 323 | 10410 | 347 | 10633 | 330 |
| 8653 | 37 | 8968 | 290 | 9727 | 265 | 10001 | 304 | 10062 | 314 | 10121 | 228 | 10210 | 323 | 10411 | 347 | 10634 | 330 |
| 8654 | 37 | 8969 | 290 | 9728 | 265 | 10002 | 304 | 10063 | 314 | 10122 | 228 | 10211 | 323 | 10412 | 347 | 10635 | 330 |
| 8655 | 30 | 8970 | 290 | 9729 | 265 | 10003 | 304 | 10064 | 313 | 10123 | 228 | 10212 | 323 | 10413 | 347 | 10636 | 330 |
| 8656 | 29 | 8971 | 290 | 9730 | 265 | 10004 | 304 | 10065 | 313 | 10124 | 229 | 10213 | 323 | 10414 | 347 | 10637 | 330 |
| 8680 | 263 | 8972 | 290 | 9731 | 265 | 10005 | 304 | 10066 | 313 | 10125 | 229 | 10214 | 324 | 10415 | 347 | 10638 | 330 |
| 8681 | 263 | 8973 | 290 | 9732 | 265 | 10006 | 304 | 10067 | 313 | 10126 | 229 | 10215 | 324 | 10416 | 345 | 10639 | 330 |
| 8682 | 263 | 8974 | 290 | 9733 | 265 | 10007 | 304 | 10068 | 313 | 10127 | 229 | 10216 | 324 | 10417 | 346 | 10640 | 330 |
| 8684 | 467 | 8975 | 290 | 9734 | 265 | 10008 | 305 | 10069 | 313 | 10128 | 227 | 10217 | 324 | 10418 | 349 | 10641 | 330 |
| 8685 | 469 | 8976 | 290 | 9735 | 265 | 10009 | 305 | 10070 | 313 | 10129 | 227 | 10218 | 324 | 10419 | 349 | 10642 | 134 |
| 8686 | 468 | 8977 | 290 | 9736 | 265 | 10010 | 305 | 10071 | 310 | 10130 | 227 | 10219 | 324 | 10420 | 349 | 10643 | 134 |
| 8687 | 468 | 8978 | 290 | 9737 | 265 | 10011 | 305 | 10072 | 310 | 10131 | 227 | 10220 | 324 | 10421 | 349 | 10644 | 134 |
| 8784 | 133 | 8979 | 290 | 9738 | 265 | 10012 | 305 | 10073 | 307 | 10141 | 323 | 10221 | 324 | 10422 | 349 | 10645 | 134 |
| 8785 | 133 | 8980 | 290 | 9739 | 265 | 10013 | 305 | 10074 | 227 | 10142 | 323 | 10222 | 324 | 10423 | 348 | 10646 | 134 |
| 8786 | 133 | 8981 | 290 | 9740 | 274 | 10014 | 305 | 10075 | 227 | 10143 | 323 | 10223 | 324 | 10424 | 348 | 10647 | 134 |
| 8787 | 133 | 8982 | 290 | 9741 | 274 | 10015 | 305 | 10076 | 227 | 10144 | 323 | 10224 | 324 | 10431 | 111 | 10648 | 371 |
| 8794 | 268 | 8983 | 290 | 9742 | 274 | 10016 | 206 | 10077 | 227 | 10145 | 323 | 10225 | 324 | 10432 | 322 | 10649 | 371 |
| 8795 | 133 | 8984 | 291 | 9743 | 274 | 10017 | 206 | 10078 | 229 | 10146 | 323 | 10226 | 324 | 10566 | 327 | 10650 | 273 |
| 8796 | 115 | 8985 | 291 | 9744 | 274 | 10018 | 206 | 10079 | 228 | 10147 | 322 | 10227 | 324 | 10567 | 327 | 10651 | 273 |
| 8797 | 116 | 8986 | 291 | 9745 | 274 | 10019 | 206 | 10080 | 228 | 10148 | 322 | 10228 | 324 | 10568 | 327 | 10652 | 273 |
| 8798 | 119 | 8987 | 291 | 9748 | 275 | 10020 | 206 | 10081 | 228 | 10149 | 322 | 10230 | 324 | 10569 | 327 | 10653 | 273 |
| 8799 | 117 | 8988 | 255 | 9749 | 275 | 10021 | 206 | 10082 | 228 | 10150 | 322 | 10231 | 324 | 10570 | 327 | 10654 | 273 |
| 8800 | 76 | 8989 | 255 | 9750 | 275 | 10022 | 308 | 10083 | 228 | 10151 | 322 | 10232 | 324 | 10571 | 327 | 10655 | 273 |
| 8803 | 77 | 9000 | | 9751 | 275 | 10023 | 308 | 10084 | 229 | 10153 | 322 | 10233 | 324 | 10572 | 327 | 10656 | 273 |
| 8806 | 75 | 9626 | 136 | 9752 | 275 | 10024 | 308 | 10085 | 229 | 10154 | 322 | 10234 | 324 | 10573 | 327 | 10657 | 273 |
| 8809 | 381 | 9627 | 136 | 9753 | 275 | 10025 | 308 | 10086 | 229 | 10155 | 323 | 10235 | 324 | 10574 | 327 | 10658 | 273 |
| 8932 | 275 | 9628 | 136 | 9754 | 275 | 10027 | 308 | 10087 | 229 | 10157 | 323 | 10236 | 324 | 10575 | 327 | 10659 | 273 |
| 8933 | 275 | 9629 | 137 | 9760 | 268 | 10028 | 308 | 10088 | 231 | 10159 | 323 | 10237 | 324 | 10576 | 327 | 10668 | 357 |
| 8934 | 275 | 9630 | 137 | 9764 | 271 | 10029 | 308 | 10089 | 231 | 10160 | 323 | 10238 | 324 | 10577 | 327 | 10669 | 357 |
| 8935 | 260 | 9631 | 137 | 9765 | 271 | 10030 | 308 | 10090 | 231 | 10161 | 323 | 10239 | 324 | 10578 | 327 | 10670 | 357 |
| 8936 | 261 | 9632 | 275 | 9766 | 271 | 10031 | 308 | 10091 | 231 | 10162 | 323 | 10240 | 324 | 10579 | 327 | 10671 | 357 |
| 8937 | 260 | 9633 | 275 | 9767 | 271 | 10032 | 308 | 10092 | 228 | 10164 | 322 | 10241 | 324 | 10580 | 327 | 10672 | 358 |
| 8938 | 260 | 9653 | 142 | 9768 | 271 | 10033 | 308 | 10093 | 227 | 10166 | 322 | 10242 | 324 | 10581 | 327 | 10673 | 358 |
| 8939 | 261 | 9654 | 142 | 9769 | 271 | 10034 | 308 | 10094 | 227 | 10168 | 322 | 10243 | 325 | 10582 | 327 | 10674 | 359 |
| 8940 | 261 | 9655 | 142 | 9772 | 30 | 10035 | 309 | 10095 | 227 | 10170 | 322 | 10245 | 325 | 10583 | 327 | 10675 | 359 |
| 8941 | 260 | 9657 | 150 | 9773 | 29 | 10036 | 309 | 10096 | 227 | 10172 | 322 | 10247 | 325 | 10584 | 327 | 10676 | 359 |
| 8942 | 261 | 9658 | 150 | 9789 | 45 | 10037 | 309 | 10097 | 229 | 10173 | 322 | 10249 | 325 | 10585 | 327 | 10677 | 432 |
| 8943 | 261 | 9659 | 150 | 9791 | 47 | 10038 | 310 | 10098 | 228 | 10175 | 323 | 10251 | 325 | 10586 | 327 | 10678 | 432 |
| 8946 | 257 | 9660 | 150 | 9793 | 49 | 10039 | 311 | 10099 | 228 | 10176 | 323 | 10253 | 325 | 10587 | 327 | 10679 | 487 |
| 8947 | 257 | 9662 | 150 | 9795 | 51 | 10040 | 310 | 10100 | 228 | 10177 | 323 | 10255 | 325 | 10588 | 327 | 10680 | 487 |
| 8948 | 257 | 9663 | 150 | 9817 | 106 | 10041 | 310 | 10101 | 228 | 10179 | 322 | 10256 | 325 | 10589 | 327 | 10681 | 487 |
| 8949 | 257 | 9664 | 150 | 9969 | 468 | 10042 | 310 | 10102 | 228 | 10181 | 322 | 10257 | 325 | 10590 | 327 | 10682 | 487 |
| 8950 | 257 | 9665 | 150 | 9971 | 281 | 10044 | 307 | 10103 | 229 | 10183 | 322 | 10258 | 325 | 10591 | 329 | 10683 | 487 |
| 8951 | 257 | 9666 | 150 | 9972 | 281 | 10045 | 316 | 10104 | 227 | 10185 | 322 | 10259 | 325 | 10592 | 329 | 10684 | 432 |
| 8952 | 257 | 9709 | 409 | 9973 | 281 | 10046 | 317 | 10105 | 227 | 10187 | 322 | 10260 | 325 | 10593 | 329 | 10685 | 432 |
| 8953 | 257 | 9712 | 265 | 9974 | 281 | 10047 | 317 | 10106 | 227 | 10188 | 322 | 10261 | 325 | 10594 | 329 | 10686 | 432 |
| 8954 | 281 | 9713 | 265 | 9975 | 281 | 10048 | 317 | 10107 | 227 | 10190 | 322 | 10262 | 325 | 10595 | 329 | 10687 | 432 |

Índice referencia / Reference index

| REF. | PAG. | REF. | PAG. | REF. | PAG. | REF. | PAG. | REF. | PAG. | REF. | PAG. | REF. | PAG. | REF. | PAG. | REF. | PAG. | | |
|-------|------|--------------|------|-------|------|-------|------|-------|------|-------|------|-------|------|-------|------|--------------|------|-------|-----|
| 10839 | 327 | 10985 | 31 | 11061 | 339 | 11157 | 339 | 11517 | 441 | 11648 | 128 | 11799 | 365 | 11860 | 297 | 11965 | 389 | M2161 | 146 |
| 10879 | 357 | 10986 | 31 | 11062 | 339 | 11158 | 339 | 11518 | 441 | 11649 | 128 | 11800 | 366 | 11861 | 297 | 11966 | 390 | M2274 | 144 |
| 10880 | 357 | 10988 | 31 | 11063 | 339 | 11159 | 339 | 11519 | 441 | 11650 | 128 | 11801 | 366 | 11862 | 297 | 11967 | 390 | M2275 | 144 |
| 10881 | 357 | 10989 | 31 | 11064 | 339 | 11160 | 339 | 11520 | 441 | 11651 | 128 | 11802 | 366 | 11863 | 297 | 11968 | 390 | M2283 | 144 |
| 10882 | 357 | 10990 | 210 | 11065 | 339 | 11161 | 339 | 11521 | 441 | 11652 | 128 | 11803 | 366 | 11905 | 322 | 11969 | 390 | M2297 | 146 |
| 10883 | 358 | 10991 | 210 | 11066 | 473 | 11162 | 339 | 11522 | 441 | 11653 | 128 | 11804 | 366 | 11906 | 116 | 11970 | 390 | M2397 | 158 |
| 10884 | 358 | 10992 | 210 | 11067 | 206 | 11163 | 339 | 11523 | 441 | 11654 | 128 | 11805 | 366 | 11907 | 116 | 11971 | 390 | M2710 | 146 |
| 10885 | 359 | 10993 | 210 | 11068 | 206 | 11164 | 339 | 11524 | 441 | 11657 | 244 | 11806 | 366 | 11908 | 117 | 11972 | 452 | M2711 | 146 |
| 10886 | 359 | 10994 | 187 | 11069 | 206 | 11165 | 339 | 11525 | 441 | 11658 | 244 | 11807 | 366 | 11909 | 117 | 11973 | 485 | M2712 | 146 |
| 10887 | 359 | 10997 | 181 | 11070 | 206 | 11166 | 339 | 11526 | 441 | 11659 | 245 | 11808 | 42 | 11910 | 119 | 11974 | 489 | M2713 | 146 |
| 10897 | 286 | 10998 | 374 | 11071 | 206 | 11167 | 339 | 11527 | 441 | 11660 | 245 | 11809 | 266 | 11911 | 119 | 11975 | 493 | M2714 | 146 |
| 10898 | 286 | 10999 | 374 | 11072 | 206 | 11168 | 339 | 11572 | 375 | 11661 | 245 | 11810 | 266 | 11912 | 325 | 11976 | 493 | M2715 | 146 |
| 10899 | 286 | 11000 | 374 | 11076 | 340 | 11169 | 339 | 11573 | 375 | 11662 | 455 | 11811 | 266 | 11913 | 108 | 11977 | 493 | M2716 | 146 |
| 10908 | 385 | 11001 | 374 | 11077 | 340 | 11170 | 373 | 11574 | 374 | 11663 | 455 | 11812 | 266 | 11914 | 108 | 11978 | 477 | M2759 | 144 |
| 10909 | 385 | 11002 | 375 | 11078 | 340 | 11171 | 373 | 11575 | 374 | 11664 | 455 | 11813 | 266 | 11915 | 88 | 11987 | 203 | M2760 | 144 |
| 10910 | 385 | 11003 | 375 | 11079 | 340 | 11172 | 373 | 11576 | 374 | 11665 | 455 | 11814 | 266 | 11916 | 88 | 11988 | 203 | M2761 | 144 |
| 10928 | 134 | 11004 | 375 | 11083 | 245 | 11173 | 373 | 11577 | 374 | 11666 | 455 | 11815 | 266 | 11917 | 102 | 11989 | 295 | M2762 | 144 |
| 10929 | 134 | 11005 | 375 | 11084 | 245 | 11174 | 373 | 11578 | 469 | 11667 | 455 | 11816 | 266 | 11918 | 102 | 11990 | 295 | M2763 | 144 |
| 10930 | 134 | 11006 | 375 | 11085 | 245 | 11175 | 373 | 11579 | 469 | 11734 | 253 | 11817 | 266 | 11919 | 102 | 11991 | 390 | M3036 | 166 |
| 10931 | 134 | 11007 | 375 | 11086 | 245 | 11176 | 373 | 11580 | 469 | 11735 | 253 | 11818 | 258 | 11920 | 102 | 11992 | 390 | M3037 | 166 |
| 10932 | 134 | 11013 | 111 | 11087 | 245 | 11177 | 373 | 11581 | 469 | 11736 | 253 | 11819 | 263 | 11921 | 102 | 11996 | 281 | M3038 | 166 |
| 10933 | 134 | 11014 | 331 | 11088 | 245 | 11178 | 373 | 11582 | 29 | 11737 | 253 | 11820 | 483 | 11922 | 102 | 11998 | 221 | M3435 | 160 |
| 10934 | 387 | 11015 | 331 | 11089 | 322 | 11179 | 373 | 11583 | 29 | 11738 | 253 | 11821 | 483 | 11923 | 94 | 12000 | 181 | M3950 | 152 |
| 10935 | 387 | 11016 | 374 | 11121 | 479 | 11180 | 373 | 11584 | 134 | 11748 | 256 | 11822 | 483 | 11924 | 94 | 12001 | 181 | M3970 | 160 |
| 10936 | 387 | 11017 | 374 | 11122 | 479 | 11181 | 373 | 11585 | 223 | 11756 | 219 | 11825 | 483 | 11925 | 94 | 12002 | 485 | M4306 | 152 |
| 10937 | 290 | 11018 | 206 | 11123 | 479 | 11482 | 473 | 11586 | 223 | 11758 | 219 | 11826 | 483 | 11926 | 94 | 12005 | 206 | M4307 | 152 |
| 10938 | 290 | 11019 | 206 | 11124 | 479 | 11484 | 469 | 11587 | 223 | 11759 | 219 | 11827 | 255 | 11927 | 98 | 12006 | 165 | M4540 | 160 |
| 10939 | 290 | 11022 | 240 | 11125 | 479 | 11485 | 469 | 11588 | 360 | 11760 | 219 | 11828 | 295 | 11928 | 158 | 12007 | 485 | M4541 | 160 |
| 10940 | 290 | 11023 | 240 | 11126 | 479 | 11486 | 471 | 11590 | 360 | 11761 | 221 | 11829 | 295 | 11929 | 158 | 12008 | 113 | M4542 | 160 |
| 10941 | 290 | 11024 | 240 | 11127 | 479 | 11487 | 471 | 11591 | 363 | 11762 | 345 | 11830 | 295 | 11930 | 150 | 12009 | 113 | M4564 | 154 |
| 10942 | 290 | 11029 | 251 | 11128 | 479 | 11488 | 471 | 11592 | 363 | 11763 | 346 | 11831 | 301 | 11931 | 150 | 12010 | 113 | M4591 | 158 |
| 10943 | 290 | 11030 | 251 | 11129 | 479 | 11489 | 469 | 11593 | 363 | 11764 | 347 | 11832 | 301 | 11932 | 153 | 12011 | 113 | M4755 | 152 |
| 10944 | 291 | 11031 | 251 | 11130 | 479 | 11490 | 469 | 11599 | 286 | 11765 | 347 | 11833 | 301 | 11933 | 154 | 12012 | 113 | M4756 | 152 |
| 10957 | 473 | 11032 | 251 | 11131 | 479 | 11491 | 469 | 11601 | 286 | 11766 | 350 | 11834 | 301 | 11934 | 154 | 12013 | 113 | M4757 | 152 |
| 10958 | 358 | 11033 | 251 | 11132 | 479 | 11492 | 469 | 11602 | 330 | 11767 | 350 | 11835 | 301 | 11935 | 91 | 12014 | 493 | M5084 | 144 |
| 10959 | 358 | 11034 | 251 | 11133 | 479 | 11493 | 471 | 11603 | 316 | 11768 | 483 | 11836 | 301 | 11936 | 91 | 12015 | 199 | M5202 | 166 |
| 10960 | 358 | 11035 | 252 | 11134 | 479 | 11494 | 471 | 11604 | 311 | 11769 | 333 | 11837 | 301 | 11937 | 91 | 12016 | 199 | M5203 | 166 |
| 10961 | 358 | 11037 | 251 | 11135 | 479 | 11495 | 471 | 11605 | 240 | 11770 | 333 | 11838 | 301 | 11938 | 91 | 12017 | 183 | M5206 | 166 |
| 10964 | 239 | 11038 | 247 | 11136 | 479 | 11496 | 439 | 11606 | 240 | 11771 | 333 | 11839 | 295 | 11939 | 250 | 12018 | 183 | M9332 | 162 |
| 10965 | 239 | 11039 | 337 | 11137 | 479 | 11497 | 441 | 11607 | 240 | 11773 | 331 | 11840 | 295 | 11941 | 221 | 12019 | 183 | | |
| 10966 | 239 | 11040 | 337 | 11138 | 479 | 11498 | 439 | 11608 | 244 | 11774 | 331 | 11841 | 295 | 11942 | 181 | 12020 | 241 | | |
| 10967 | 239 | 11041 | 337 | 11139 | 479 | 11499 | 438 | 11609 | 244 | 11775 | 331 | 11842 | 295 | 11943 | 366 | 12021 | 241 | | |
| 10968 | 239 | 11042 | 337 | 11140 | 479 | 11500 | 438 | 11610 | 244 | 11776 | 268 | 11843 | 295 | 11946 | 259 | 12022 | 253 | | |
| 10969 | 239 | 11043 | 337 | 11141 | 479 | 11501 | 438 | 11611 | 286 | 11777 | 271 | 11844 | 295 | 11947 | 259 | 12023 | 253 | | |
| 10970 | 239 | 11044 | 337 | 11142 | 479 | 11502 | 438 | 11612 | 286 | 11778 | 281 | 11845 | 299 | 11949 | 271 | 12024 | 61 | | |
| 10971 | 194 | 11045 | 340 | 11143 | 445 | 11503 | 438 | 11613 | 286 | 11780 | 287 | 11846 | 299 | 11950 | 271 | 12025 | 61 | | |
| 10972 | 192 | 11046 | 340 | 11144 | 445 | 11504 | 438 | 11615 | 286 | 11781 | 287 | 11847 | 299 | 11951 | 287 | 12026 | 61 | | |
| 10973 | 194 | 11047 | 340 | 11145 | 339 | 11505 | 438 | 11616 | 341 | 11782 | 287 | 11848 | 299 | 11952 | 287 | 12027 | 61 | | |
| 10974 | 194 | 11048 | 337 | 11146 | 339 | 11506 | 438 | 11617 | 341 | 11787 | 287 | 11849 | 299 | 11953 | 287 | 12028 | 61 | | |
| 10975 | 447 | 11049 | 337 | 11147 | 339 | 11507 | 441 | 11626 | 475 | 11788 | 287 | 11850 | 299 | 11954 | 287 | 12029 | 102 | | |
| 10976 | 447 | 11050 | 337 | 11148 | 339 | 11508 | 438 | 11627 | 475 | 11789 | 287 | 11851 | 297 | 11955 | 287 | 12030 | 94 | | |
| 10977 | 447 | 11051 | 337 | 11149 | 339 | 11509 | 438 | 11628 | 441 | 11790 | 287 | 11852 | 297 | 11956 | 333 | 12031 | 199 | | |
| 10978 | 447 | 11052 | 337 | 11150 | 339 | 11510 | 439 | 11636 | 247 | 11791 | 287 | 11853 | 297 | 11957 | 112 | 12032 | 199 | | |
| 10979 | 31 | 11053 | 337 | 11151 | 339 | 11511 | 441 | 11637 | 247 | 11792 | 287 | 11854 | 297 | 11958 | 112 | 12033 | 199 | | |
| 10980 | 31 | 11054 | 340 | 11152 | 339 | 11512 | 441 | 11640 | 221 | 11794 | 287 | 11855 | 297 | 11959 | 113 | 12034 | 249 | | |
| 10981 | 31 | 11055 | 340 | 11153 | 339 | 11513 | 440 | 11641 | 491 | 11795 | 287 | 11856 | 297 | 11960 | 113 | M0010 | 160 | | |
| 10982 | 31 | 11058 | 492 | 11154 | 339 | 11514 | 440 | 11645 | 128 | 11796 | 287 | 11857 | 297 | 11961 | 113 | ABC | | | |
| 10983 | 31 | 11059 | 339 | 11155 | 339 | 11515 | 440 | 11646 | 128 | 11797 | 365 | 11858 | 297 | 11962 | 112 | M1462 | 154 | | |
| 10984 | 31 | 11060 | 339 | 11156 | 339 | 11516 | 441 | 11647 | 128 | 11798 | 365 | 11859 | 297 | 11963 | 112 | M1538 | 208 | | |

Iconos / Icons



INOX STAINLESS STEEL 304
Inox AISI 304

INOX STAINLESS STEEL 430
Inox AISI 430

INOX STAINLESS STEEL 201
Inox AISI 201

CARBON STEEL
Acero de carbono
Carbon Steel

CORK
Corcho
Cork

ACRYLIC
Acrílico
Acrylic

ABS PLASTIC
ABS Plástico
ABS Plastic

PC POLYCARBONATE
Policarbonato
Polycarbonate

PP POLYPROPYLENE
Polipropileno
Polypropylene

EPP EXPANDED POLYPROPYLENE
Polipropileno expandido
Expanded polypropylene

HD PE 500
Poliétileno de alta densidad
High density polyethylene

NYLON
Nylon

SILICONE
Silicona
Silicone

RUBBER
Caucho
Rubber

THERMO PLASTIC RUBBER
Caucho termoplástico
Thermoplastic Rubber

STABILISED WOOD
Madera estabilizada
Stabilised wood

OAK WOOD
Madera de roble
Oak Wood

ZEBRA WOOD
Madera de zebrano
Zebra wood

ROSEWOOD WOOD
Madera de palisandro
Rosewood wood

PAKKA WOOD
Madera de pakka
Pakka wood

MIKARTA WOOD
Madera de mikarta
Mikarta wood

OLIVE WOOD
Madera de olivo
Olive wood

ACACIA WOOD
Madera de acacia
Acacia wood

BEECH WOOD
Madera de haya
Beech wood

BAMBOO WOOD
Madera de bambú
Bamboo wood

3 CAPAS ANTIADHERENTE NON-STICK LAYERS
Triple capa antiadherente
Triple non-stick coating

FONDO SISTEMA SANDWICH
Sandwich bottom system

SLATE
Pizarra
Slate

COTTON
Algodón
Cotton

KRAFT
Kraft

PORCELAIN
Porcelana
Porcelain

AL ALUMINIUM
Aluminio
Aluminium

CU COPPER
Cobre
Copper

CAST IRON
Hierro fundido
Cast iron

ENAMELLED IRON
Hierro esmaltado
Enamelled iron

ZINC
Zinc

GLASS
Glass
Cristal

BOROSILICATE
Borosilicato
Borosilicate

FIBERGLASS
Fiberglass

PVD COLOR
Color PVD
PVD color

“
Diseño propio
Designed in-house

Modular
Modular

Apto para fogón eléctrico
Suitable for Electric Cooker

Apto para horno
Suitable for Oven

Lavar a mano
Hand Wash

No fuego directo
No direct fire

Apto para congelador
Suitable for Freezing

MÁX. 220°C
Temperatura máxima
Max. temperature

Acabado brillo
Mirror finish

No apto para contacto alimentario
Food contact not safe

Recubrimiento antiadherente Quantanium
Non-stick coating Quantanium

Apilable
Stackable

Sostenible
Sustainable

Apto para gas
Suitable for conventional Gas Cooker

Apto para microondas
Suitable for Microwave

No apto para horno
Not Suitable for Oven

Apto para lavadora
Machine Washable

Hidratar con aceite de oliva
Hydrate with Olive Oil

Apto para contacto alimentario
Food contact Safe

Acabado satin
Satin finish

Recubrimiento non-stick
Non-tick coating

Triple capa antiadherente
Triple non-stick coating

Ligero
Lightweight

Apto para vitrocerámica
Suitable for Vitroceramic

Apto para inducción
Suitable for Induction Cooker

Apto para lavavajillas
Dishwasher safe

No apto para microondas
Not Suitable for Microwave

Soporta hasta 80°C
Until 80°C suport

Combinable con otros productos del catálogo
Combinable with other products in the catalog.

Antideslizante
Anti-slip

Espesor material
Thickness

BBQ
BBQ

Fondo sistema sandwich
Sandwich bottom system

**Si tienes alguna sugerencia o simplemente quieres saludarnos,
¡No dudes en contactarnos!**

For any suggestion or just to greet us, please do not hesitate to contact us!

comaspartners@comaspartners.com

**Y si lo que quieres es estar al corriente de nuestras noticias y novedades,
únete a nuestra comunidad online o suscríbete a nuestro newsletter:**

And if you want to be aware of our news and novelties, join our online
community or subscribe to our newsletter.

newsletter@comaspartners.com



@comasandpartners



@comasandpartners



@comas-and-partners

**El contenido del catálogo está sujeto a modificaciones.
Los datos técnicos y los precios son válidos salvo error tipográfico.**

Texts and images published on this catalogue may contain technical inconsistencies or
typographical errors. The information is subject to periodic changes.

